

INSTRUKTION

Askeudtag
X 137598/01/01-09-2006

- Askeudtag for MULTI-HEAT
- Ascheaustragung für MULTI-HEAT
- Ash clear out for MULTI-HEAT

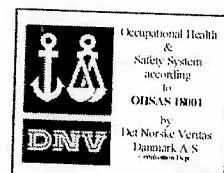
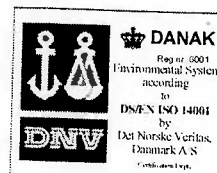
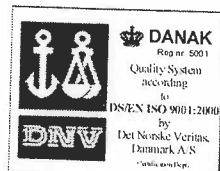

INSTRUKTION

Askeudtag
2/2

Leverings omfang. / Lieferumfang. / Delivery, content.

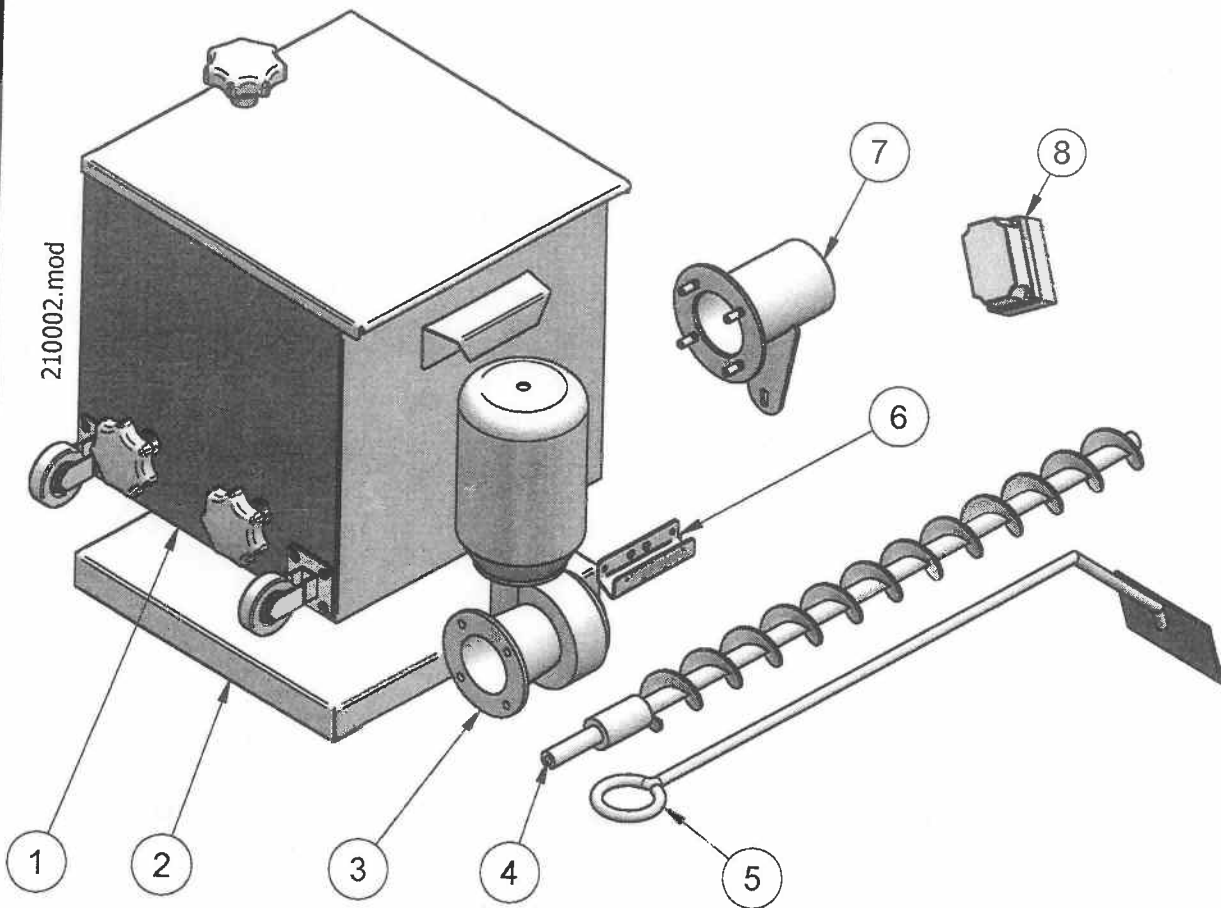

Pos	DK	DE	EN
1	Askebox	Aschebox	Ashbox
2	Sokkel, højde indstillelig.	Sokkel, höhenverstellbar.	Plinth, adjustable hight.
3	Gear motor	Getriebemotor	Gear motor
4	Askesnegl	Ascheaustragungsschnecke	Ash worm
5	Skraber	Schraber	Scraper
6	Microswitchholder (Dørsikring)	Microswitchhalter (Türsicherung)	Microswitchholder (Door safeguard)
7	2 x montageflange	2 x Montageflansch	2 x Installation flange
8	Elbox	Elbox	Elbox

INSTRUKTION

Askeudtag
3 / 3

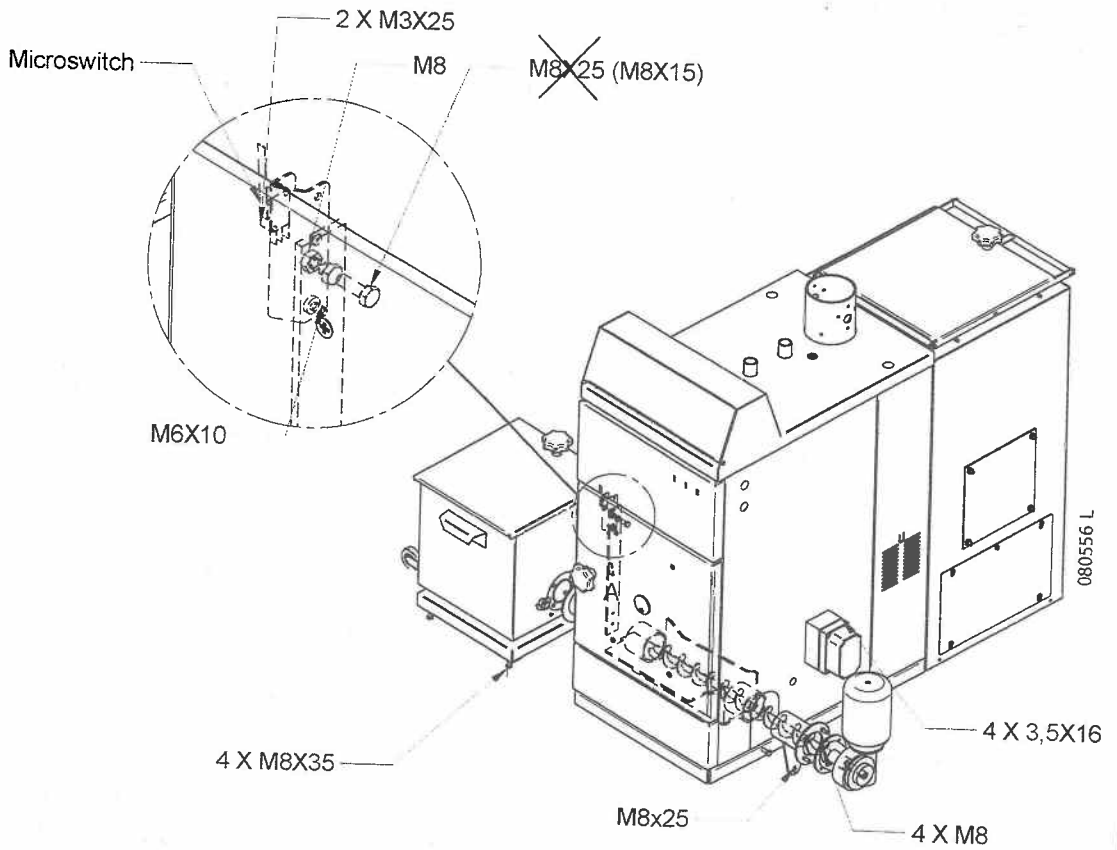
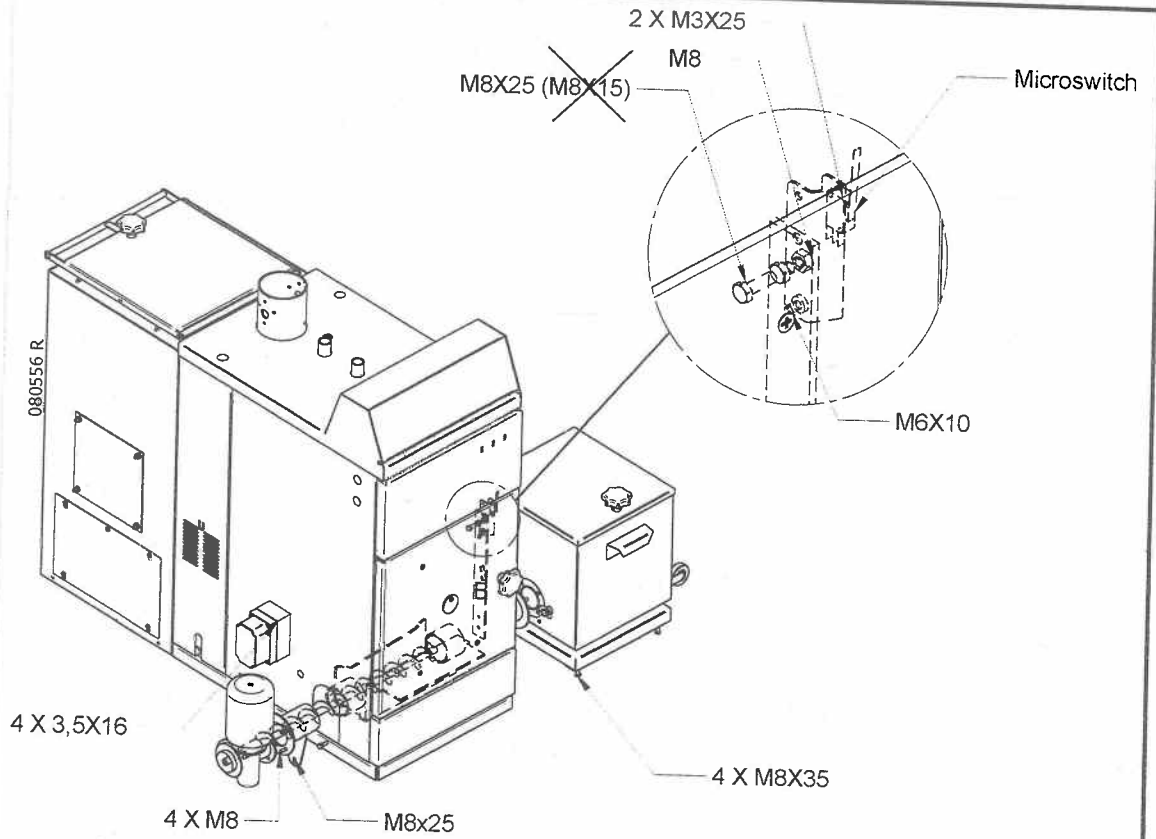

Forbindelsesskema / Verdrahtungsplan / Wiringdiagramm.

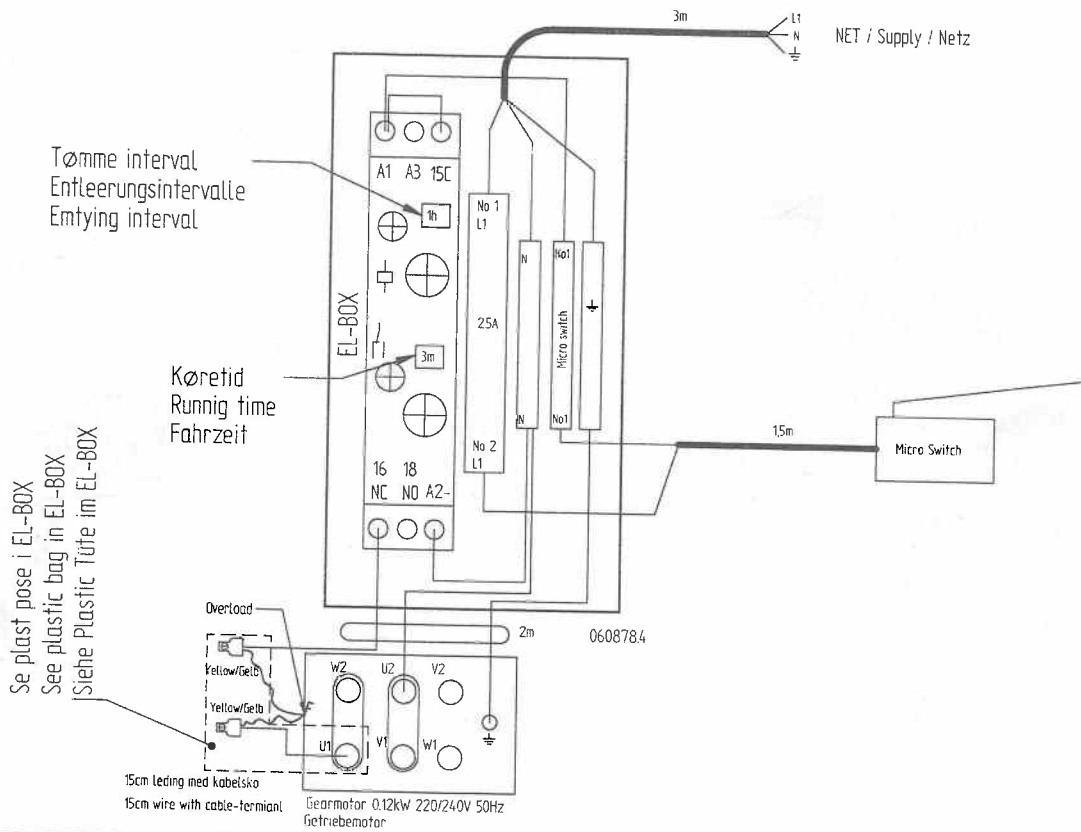

Tømning af askebox / Aschenbox Entleeren / Ashbox emptying

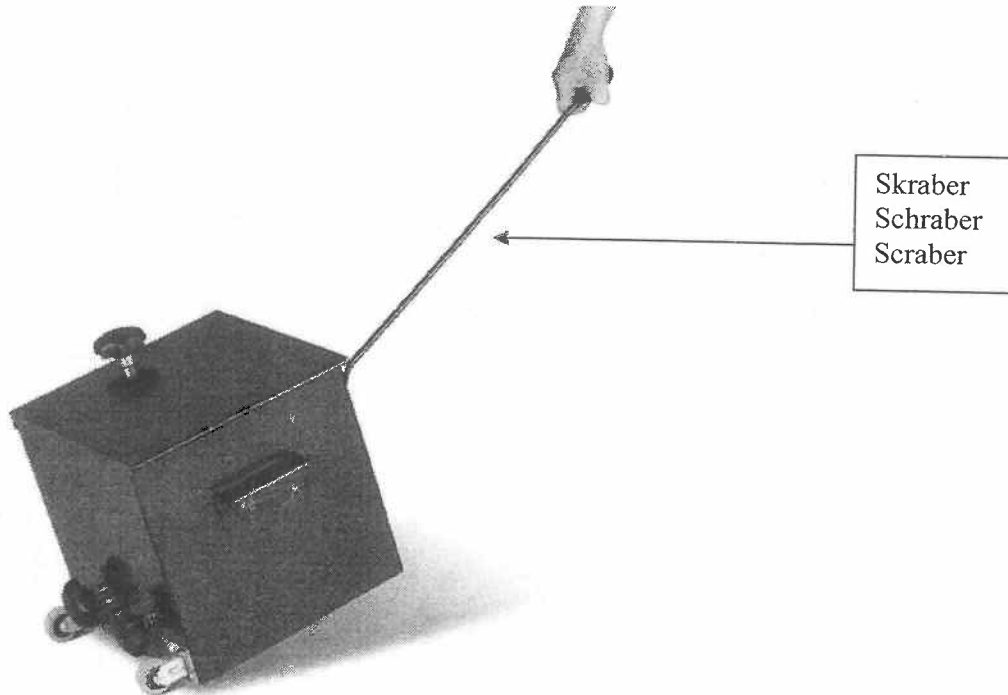

Se plast pose i EL-BOX
 See plastic bag in EL-BOX
 Siehe Plastic Tüte im EL-BOX

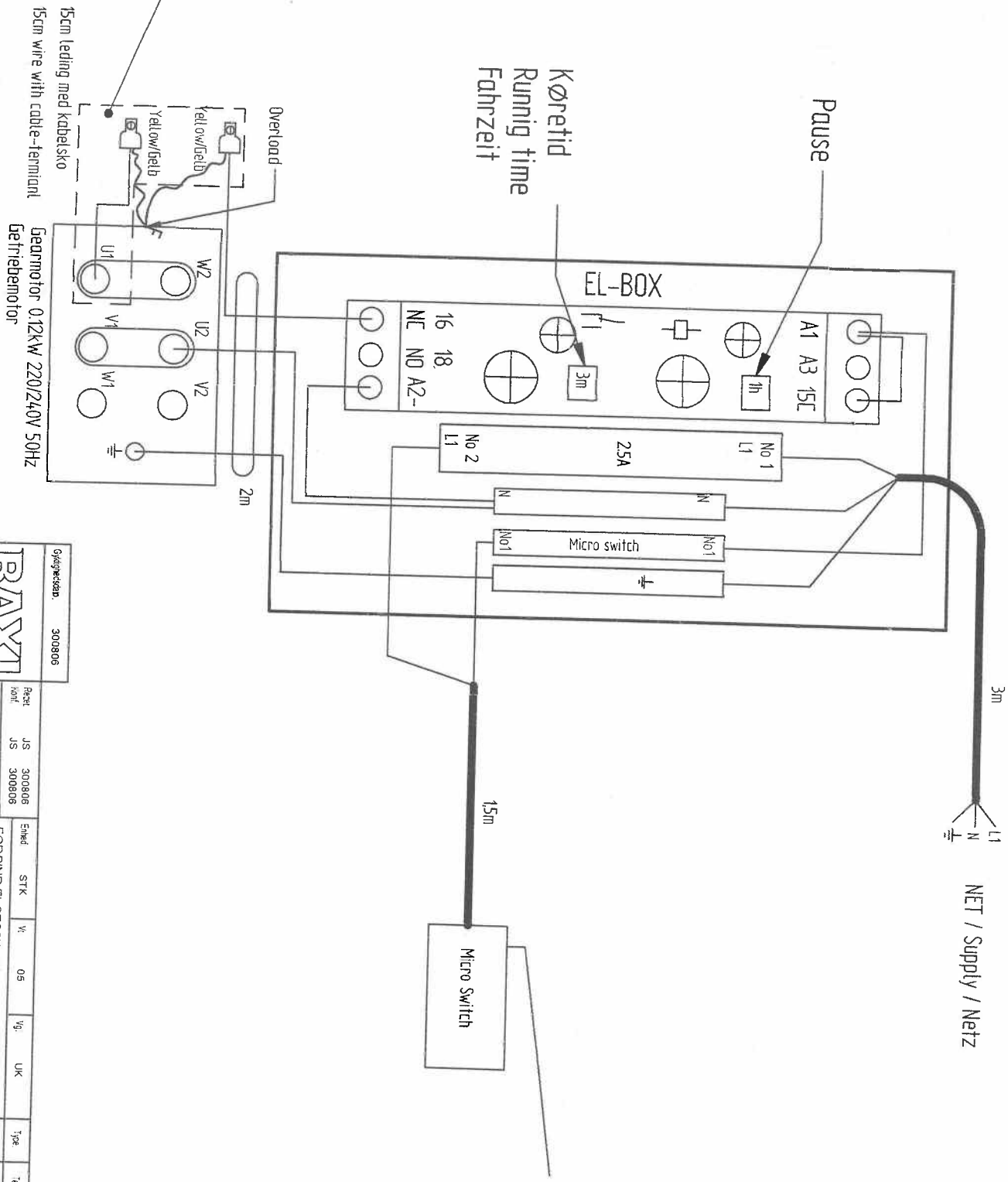

Geføjeskema 300806

BAVI

Rek. kont. no.:	US	300806	Einheit	STK	1/1	05	UK	Type	Testnr.	Rev.
Teg. no.:	AN	151205	FORBIND ELSKEMA AU T ASKE HS							
	AN	151205	MULTI HEAT							
									060878	4