

Maintenance Manual

Pellet Boiler

Nano-PK 6-15

HARGASSNER
HEIZTECHNIK DER ZUKUNFT



HARGASSNER Ges mbH

A 4952 Weng, Upper Austria

Tel.: +43/7723/5274-0

Fax: +43/7723/5274-5

office@hargassner.at

www.hargassner.com

EN - V02 07/2021

Chapter I: Service and Maintenance	3
1 Maintenance overview	3
2 Preparation for cleaning.	4
3 Service manual mode (function test)	4
4 Cleaning.	6
4.1 Overview of components	6
4.2 Cleaning the flue pipe and deflection box	6
4.3 Cleaning the turbulators and the turbulator chamber.	7
4.4 Cleaning the exhaust fan	7
4.5 Cleaning the cleaning lid	7
4.6 Cleaning the combustion chamber and post combustion chamber	7
4.7 Cleaning the ignition	9
4.8 Cleaning the vacuum turbine.	9
4.9 Cleaning the lambda sensor	9
4.10 Cleaning the pellet day hopper	9
5 Checking the double rotary valve	10
6 Cleaning and checking the suction system	10
7 Checking the RAS capacitor	10
8 Software updates	10
9 Calibrating the lambda sensor	11
10 Test run	11
Chapter II: Lubrication plan	12
1 Lubricants	12
2 Lubrication points.	12
Chapter III: Advanced service tasks	13
1 Replacing the refractory stone	13
2 Replacing the pellet vacuum turbine's carbon brushes	14
Chapter IV: Parameters	15
1 Parameter list - Service	15

Chapter I: Service and Maintenance

1 Maintenance overview

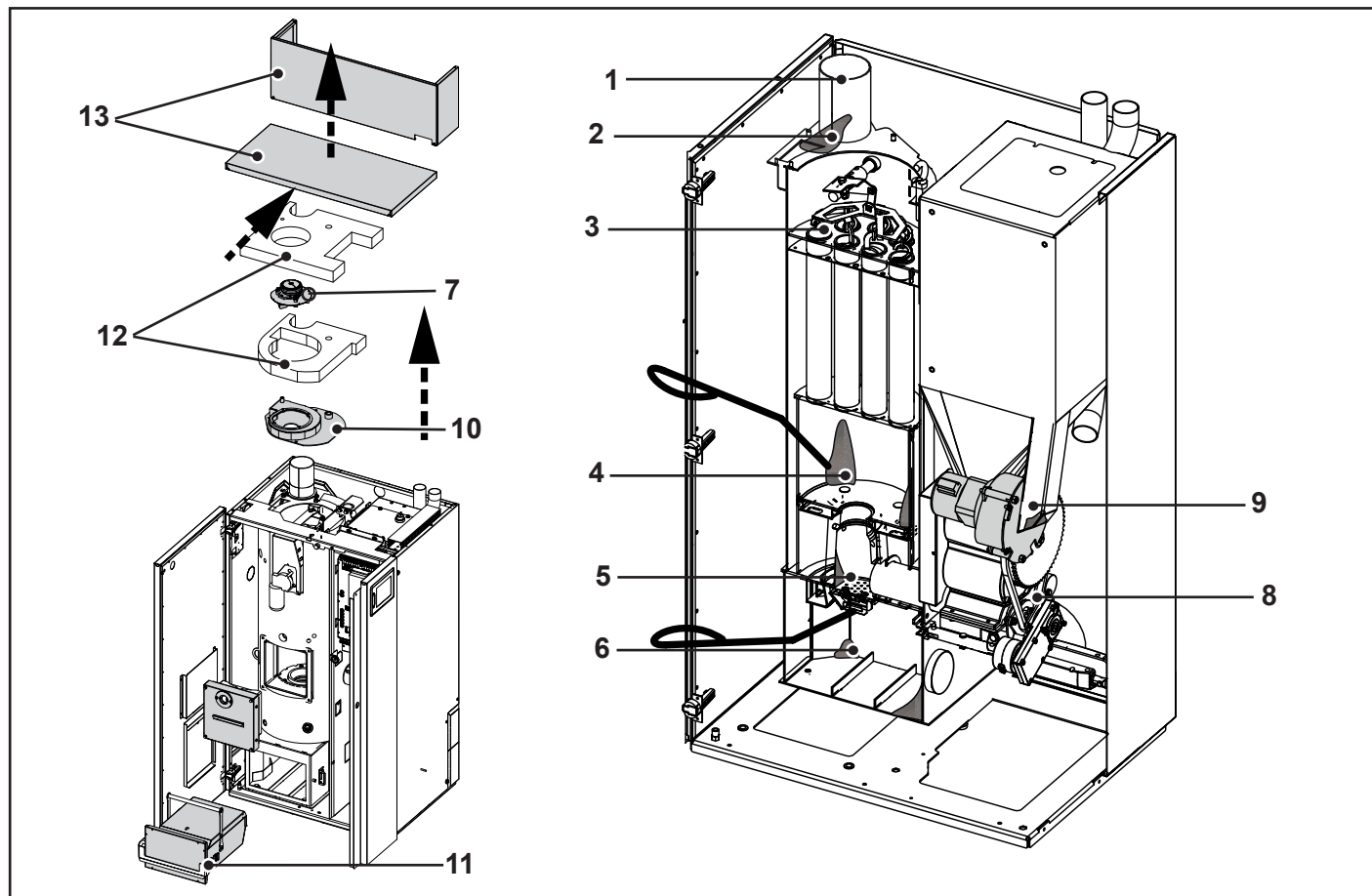

Pos.	Tasks of maintenance	Frequency (a = annually ¹)
1	Clean flue pipe	2x a
2	Clean deflection box	2x a
3	Tap residue off the turbulators and clean them	1x a
4	Clean post combustion chamber with poker (Visual check via inspection glass)	1x a (as required)
5	Clean combustion chamber with poker	1 x a (as required)
6	Remove the ash pan and clean out the ash under the grate	1x a
7	Dismount exhaust fan and clean housing and impeller	1x a
8	Grease stoker chain and check chain tension	1x a
9	Clean pellet vacuum turbine	1x a
10	Disconnect, remove and clean the lambda sensor	1x a
11	Empty the ash pan	as required
12	Remove the insulation pieces	-
13	Remove the maintenance lids	-

¹ At least once annually and no later than after 4000 full-load hrs, 8000 partial-load hrs or after a message has appeared on the control unit

2 Preparation for cleaning

- Switch off the boiler on the control unit (BCE) (operating mode **F. Off**)
 - Let boiler cool down
- Talk to the customer before beginning the maintenance process
- Take any problems and wishes the customer expresses into consideration when performing the maintenance tasks

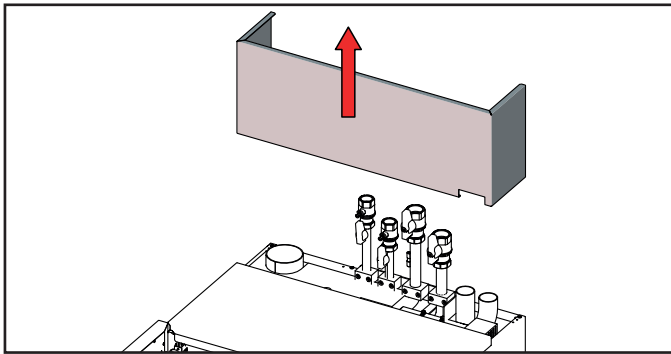

- Remove top maintenance lid
- Open left cover door
- Remove the hydraulic panel by lifting it upwards

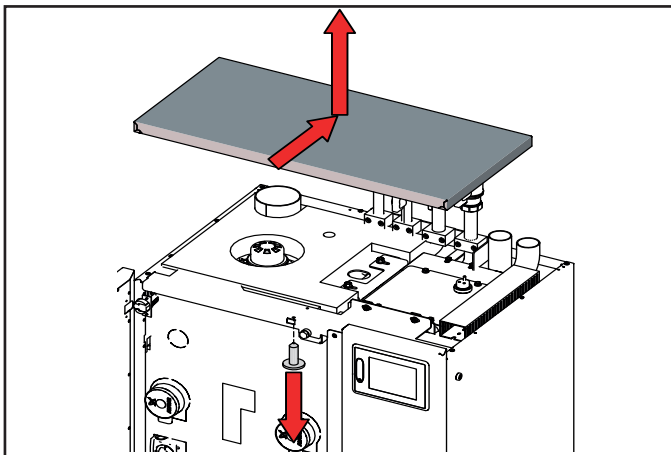

- Undo the screw in the maintenance lid
- Push maintenance lid slightly backwards and lift upwards to remove

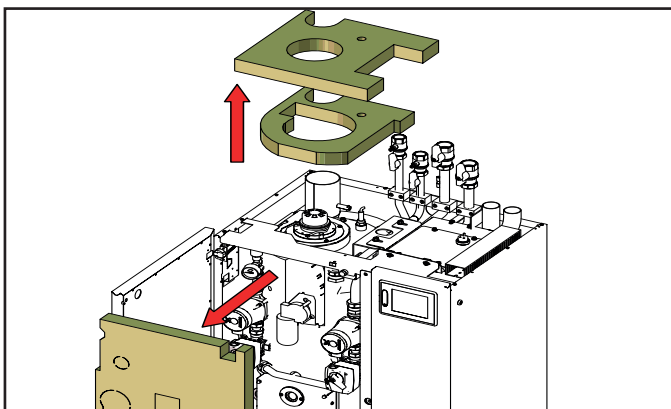

- Remove the insulation pieces
- Select manual mode

3 Service manual mode (function test)

- Used to check all the electrical functions
- Manually operate the drives to check them or if there is an error



- Activate manual mode and service
- A code has to be entered to activate them

- To activate the function, press or press and hold the button.
- To deactivate the function, press again or release the button
- To activate continuous operation (max. 2 minutes), double-tap on the button when the service manual mode is activated

Only the selected function is activated. All other functions are inactive.

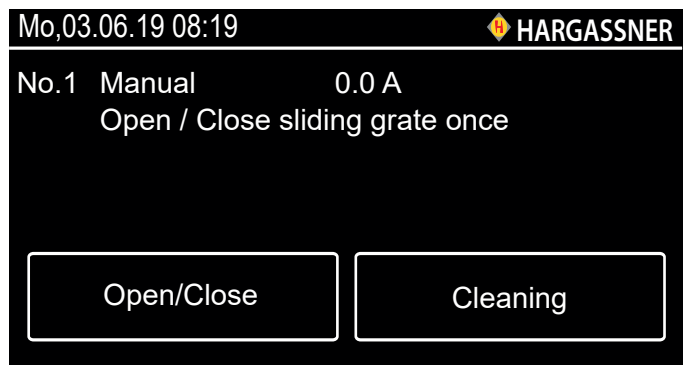

- No. 1 Function check on the sliding grate
- Pressing the button opens and closes the sliding grate once.
 - Generated ash drops into the ash pan
 - Press the button every time the boiler was cleaned

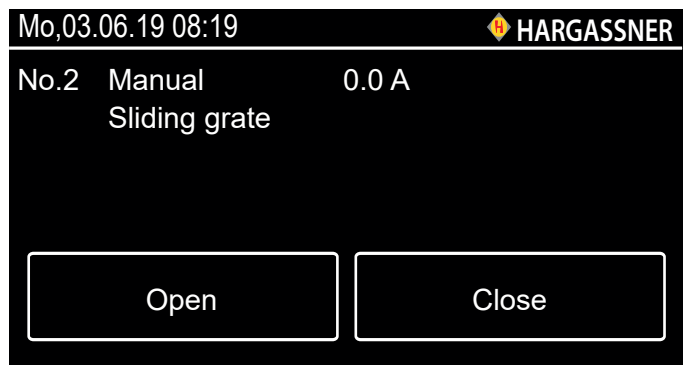

- No. 2 Functional test of sliding grate
- Pressing the button either opens or closes the sliding grate once.

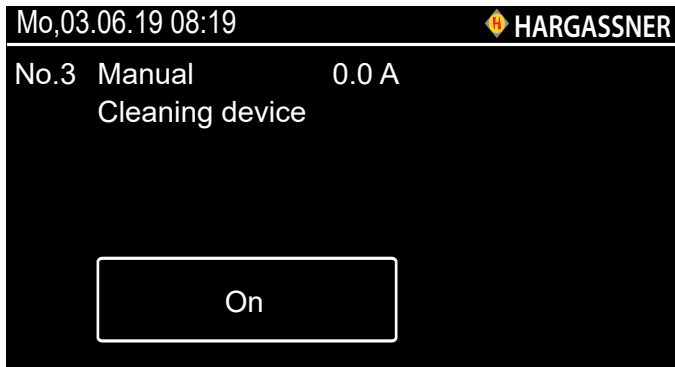

No. 3 Function check on the cleaning device
 → Grate opens completely and cleaning motor starts running
 → Press the button again to end the function check. The cleaning motor will move to its final position and the grate will close.

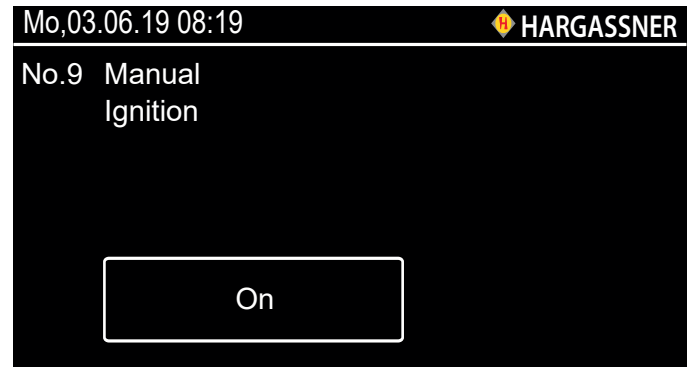

No. 9 Function check on the ignition
 → Monitor the ignition during the test run
 → **There is a risk of burns**
 ⇒ See „Maintenance overview“ on page 3

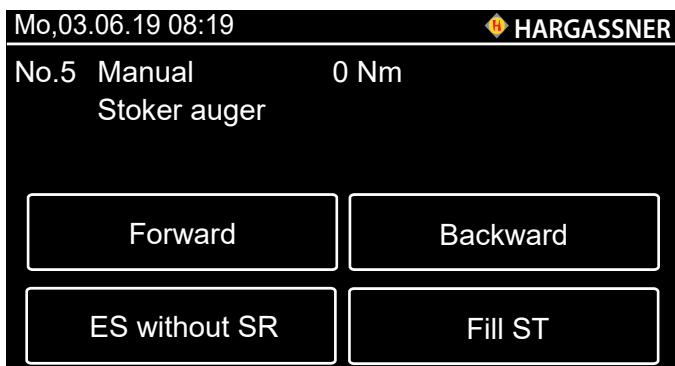

No. 5 Function and rotation check of stoker auger motor
 → Manual Forward and Backward to fill the stoker auger
 → Press Backward button only briefly

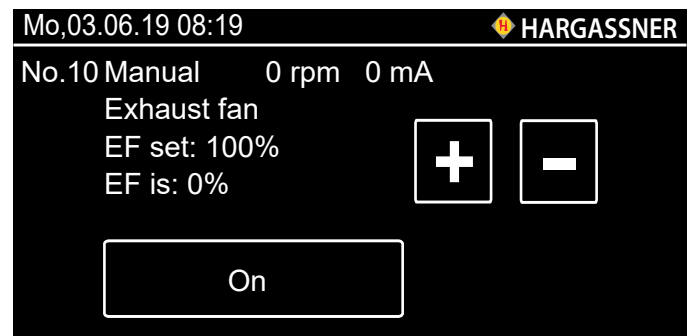

No. 10 Function check on the exhaust fan

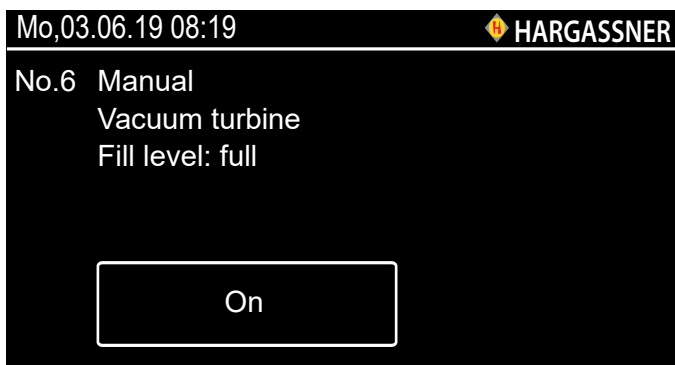

No. 6 Functional test of vacuum turbine

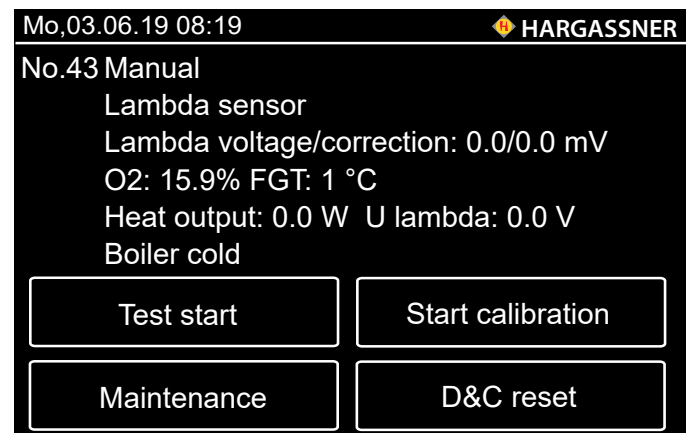

No. 43 Calibration of the lambda sensor
 ⇒ See „Calibrating the lambda sensor“ on page 11
 → When a correction value is displayed, the calibration has been completed
 → If the value is not reached the message "Lambda sensor defective" will be displayed
 → Calibrate the lambda sensor at the end of the maintenance process
 → If the maintenance process is activated in service mode, the maintenance process has to be reset after the calibration
 → Service manual mode no. 59

4 Cleaning

→ Disconnect the boiler's power supply before cleaning or performing maintenance tasks on any moving parts

4.1 Overview of components

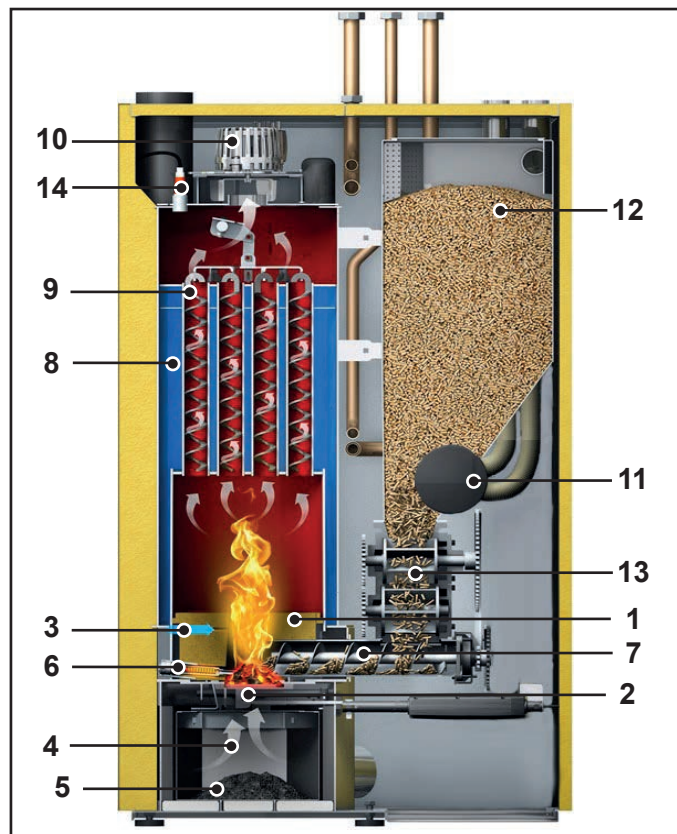

Pos.	Description
1	Fully refractory-lined combustion chamber
2	Sliding grate
3	Secondary air stream with inlet openings
4	Primary air
5	Ash pan
6	Automatic ignition
7	Stoker auger
8	Heat exchanger
9	Turbulators with automatic heat exchanger cleaning
10	Exhaust fan
11	Wood pellet vacuum turbine
12	Pellets day hopper with level indicator
13	Double rotary valve
14	Lambda sensor

4.2 Cleaning the flue pipe and deflection box

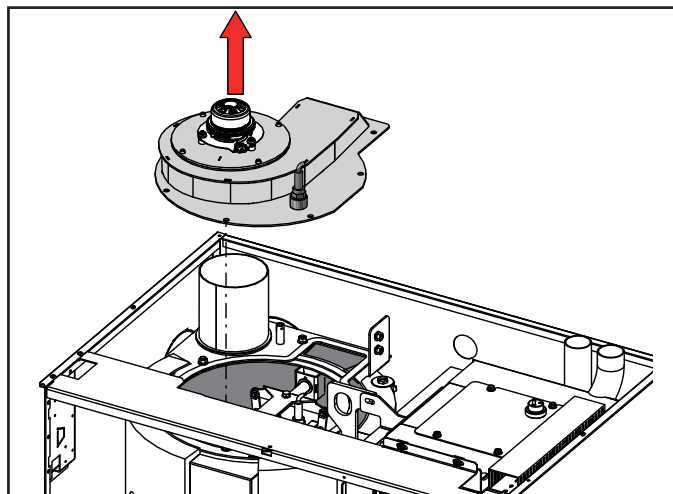

- Remove the exhaust fan housing
- Disconnect the lambda sensor and flue gas sensor
 - Pay attention to plugs
 - Cleaning the lambda sensor
- ⇒ See „Cleaning the lambda sensor“ on page 9

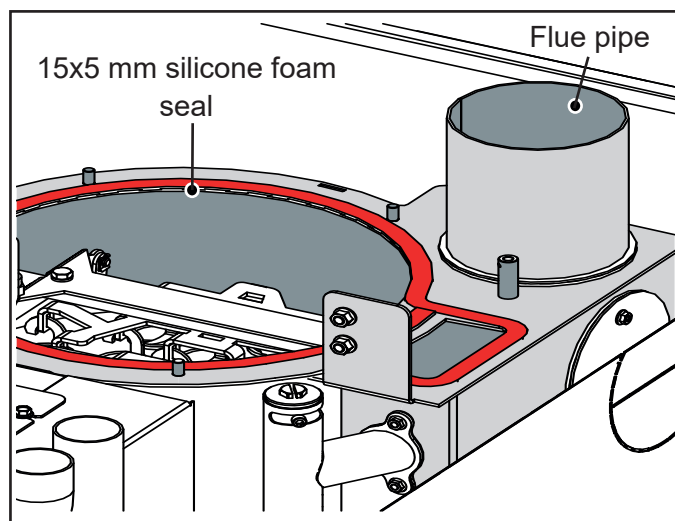

- Check the flue pipe for fly ash
- Check and clean the flue pipe
 - Replace the 15x5 mm silicone foam seal if necessary
- **If the seal is defective, false air will be drawn in and will go straight to the lambda sensor**
- **The combustion controller will be wrongly actuated and more fuel than what can be burned cleanly will be transported into the boiler**

4.3 Cleaning the turbulators and the turbulator chamber

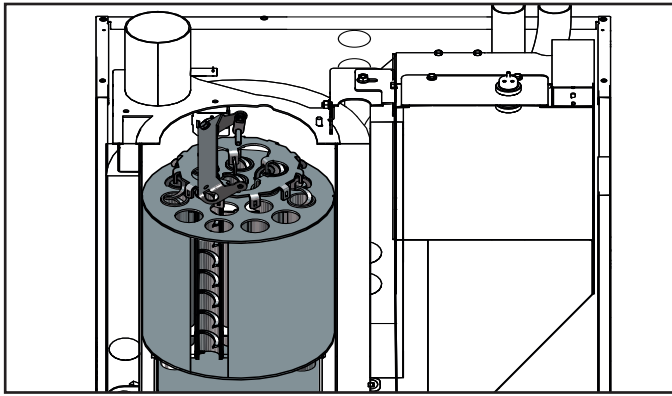

- Remove the protective panel
- Remove the clevis pin
 - Spray with lubricant spray before putting it back in place
- Unhook the turbulators
- Tap off the turbulators and clean the turbulator space

4.4 Cleaning the exhaust fan

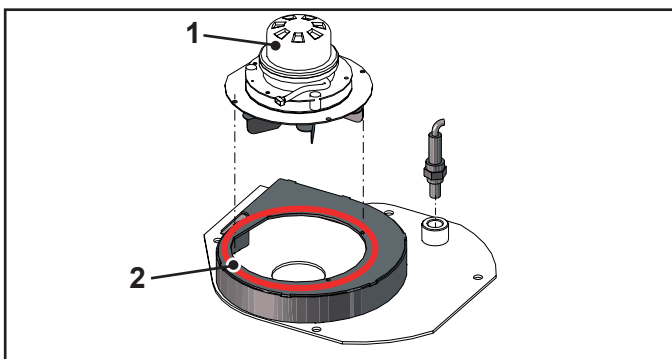

- Dismount the exhaust fan (1)
- Clean housing and impeller
 - Do not use air pressure to clean them
 - Use a brush and a vacuum cleaner
- If necessary, replace the 8x3 mm ceramic fibre seal (2)

4.5 Cleaning the cleaning lid

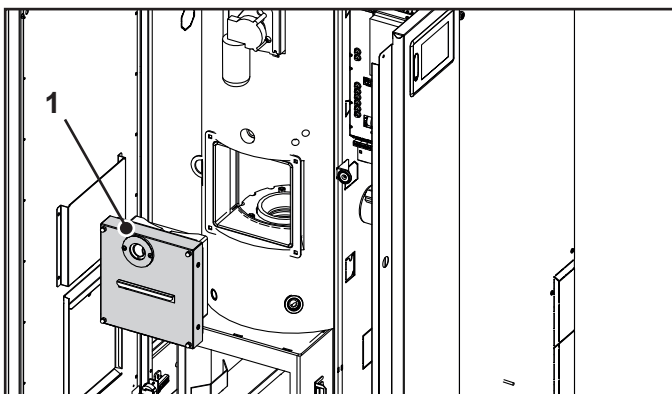

- Dismount and clean the cleaning lid (1)
- Clean inspection glass
- Check the seal

4.6 Cleaning the combustion chamber and post combustion chamber

- Before you start cleaning, check whether the deposited ash is distributed evenly
- Replace the seal if the ash cone is broken
- Open the sliding grate in order to clean the combustion chamber

⇒ See „Service manual mode (function test)“ on page 4

NOTE	
i	<p>Clean combustion chamber while exhaust fan is running</p> <ul style="list-style-type: none"> → Ash can be swirled around during the cleaning process and will be sucked out by the running exhaust fan → Less dirt in the boiler room

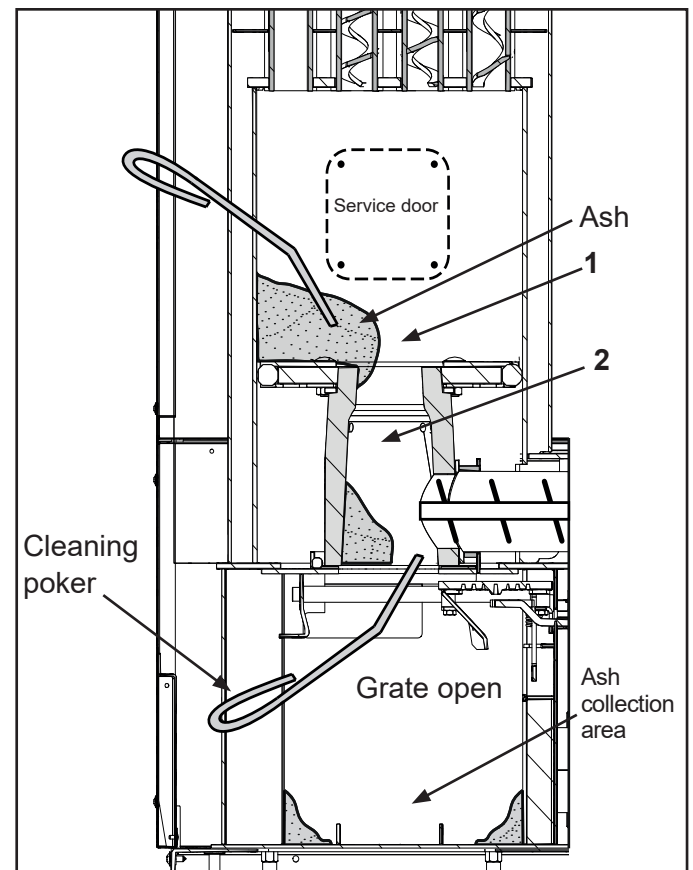

With the selector switch on **Manual**, select function no. 2 and open the sliding grate completely by pressing the **Open** button

- Check the flame concentration hole (1) (opening in the refractory stone through which the flame enters the post-combustion chamber)
- Remove the ash pan and clean the combustion chamber (2) with the cleaning poker

4.6.1 Cleaning and emptying the ash pan

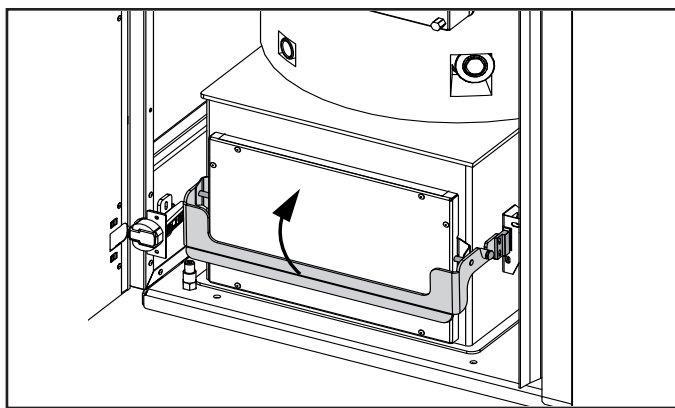

- To unlock the ash pan, pull handle upward

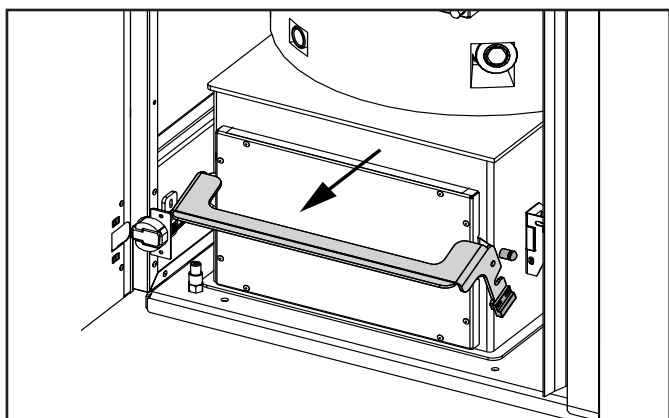

- Pull out the ash pan to the front

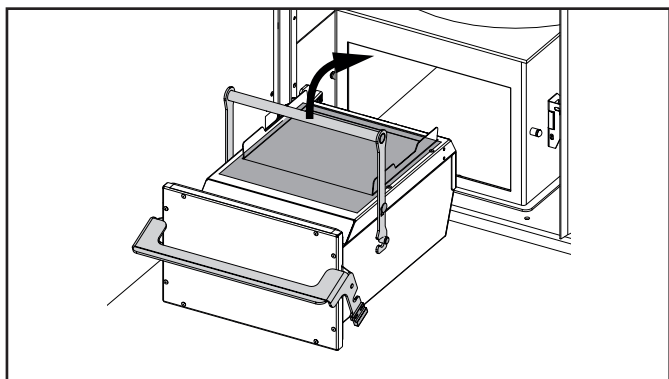

- Place transport plate on the ash pan opening
 - The transport plate is located inside on the left cover door
- Fold transport handle upwards
 - The ash pan can now be easily transported
- Clean and remove any clinker from the sliding grate and stoker auger
 - Lock the motor
 - Open the sliding grate (manual mode) and remove the bolts
 - Pull the sliding grate's bracket down and take the grate rods out
 - Take out the grate, clean it and remove any clinker from it (vacuum and sand/smooth it)
 - Clean and remove any clinker from the stoker auger

- Spray the grate rod with temperature-resistant spray before putting the grate back in

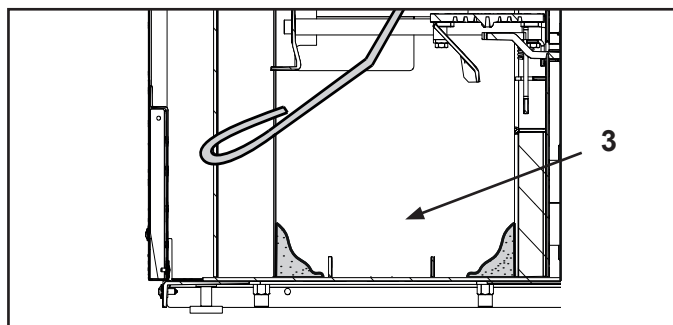

- Clean the ash collection area (3)
- To re-position and lock the ash box, proceed in reverse order
- Close the ash pan completely and ensure that it is firmly locked
- Clear the error on the display after emptying the ash pan

4.7 Cleaning the ignition

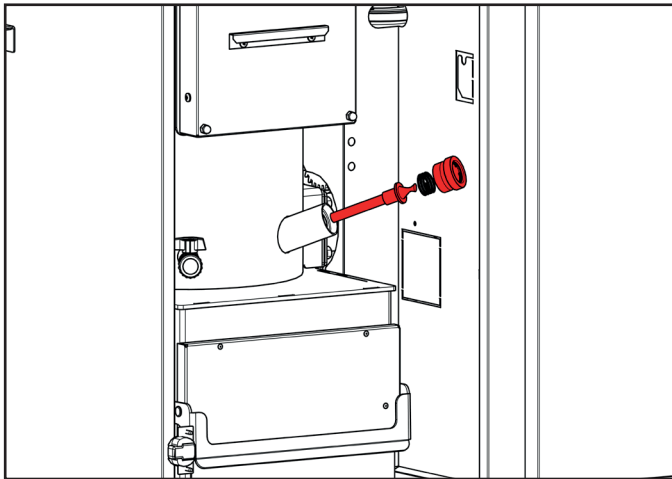

- Unscrew the ignition
 - Do not damage the ignition (ceramic component)
- Clean ignition and ignition sleeve (on the boiler) with vacuum cleaner
 - Mount ignition hand-tight only

4.8 Cleaning the vacuum turbine

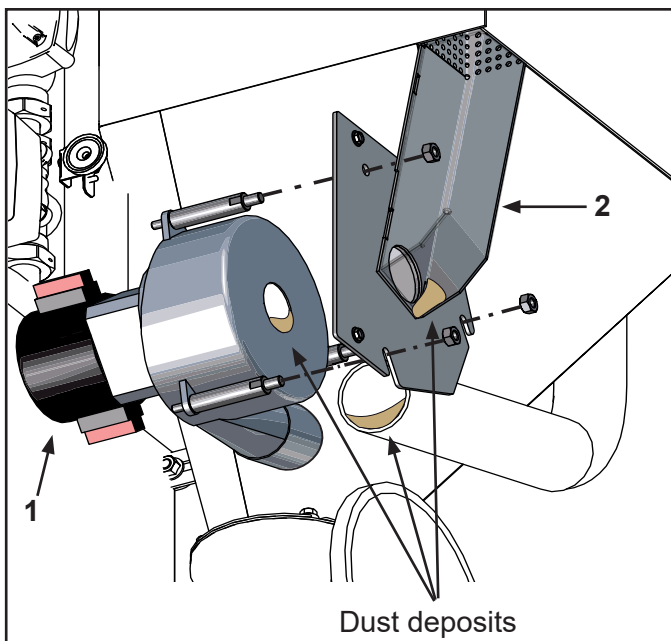

- Only clean this component if dust is present
- Replace the carbon brushes after 400 operating hours
 - ⇒ See „Replacing the pellet vacuum turbine’s carbon brushes“ on page 14
- Dismount the pellet vacuum turbine (1)
- Loosen the 3 fixing points from the vacuum turbine
 - Studs remain at the turbine
- Loosen hose clamp and remove return air hose from the vacuum turbine
- Remove the dust from the vacuum turbine, channel (2) and return air hose

4.9 Cleaning the lambda sensor

i	NOTE
	Do not tap the lambda sensor <ul style="list-style-type: none">• Do not blow it with compressed air• Do not use sharp objects or chemical cleaning agents (brake cleaner, etc.)

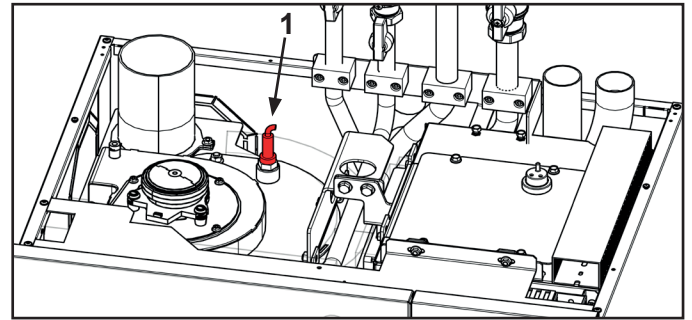

- Unscrew the lambda sensor (1) from the exhaust fan housing
- Place sensor head down
 - Debris falls down
- Vacuum the sensor
- Calibrate the lambda sensor and then put it back in place once the maintenance process is complete
 - ⇒ See „Calibrating the lambda sensor“ on page 11

4.10 Cleaning the pellet day hopper

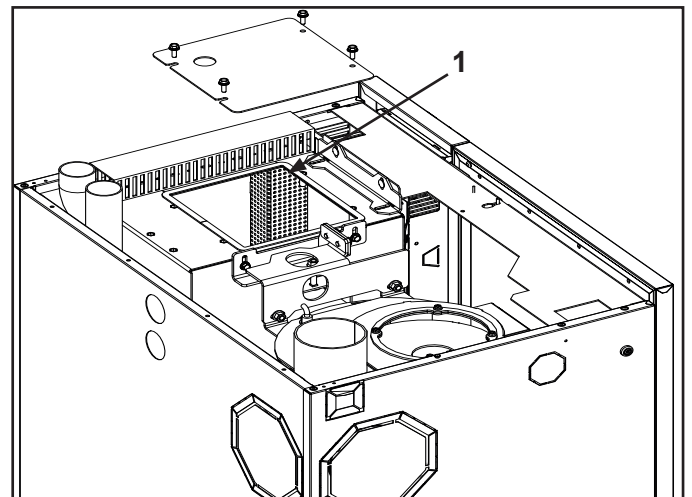

- Check and clean the suction system
 - Take off the lid and check the filter basket (1)
 - The filter basket has to be clean
 - Move the pellets to the side and check for dust and dirt
 - The pellets do not have to be cleared out
- Once the cleaning is complete, put all the parts you've removed back in place

5 Checking the double rotary valve

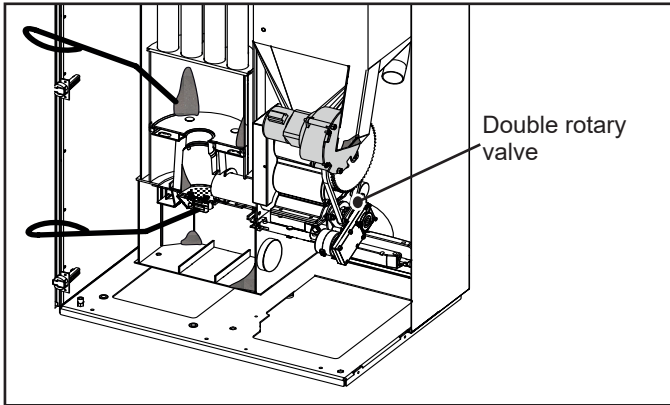

- Check the chain tension and, if necessary, adjust the tension
- Lubricate the chain

6 Cleaning and checking the suction system

- Check the hoses for wear and holes
- Check them by inspecting and feeling them
 - White patches of discolouration on the red coating indicate wear
 - Replace the hose or add a metal bracket

7 Checking the RAS capacitor

- Check the capacitor and, if necessary, replace it
 - Every 10 years
 - The capacitor is attached to the motor or the board

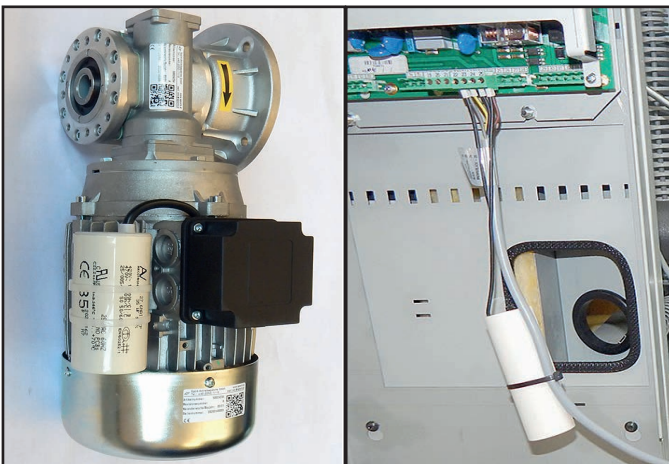

- Make a note of when (day and year) and the number of operating hours after which the capacitor has been changed

8 Software updates

→ To ensure the warranty extension is granted, the boiler's software must be up to date

- Tap on the Hargassner symbol and check the software version before updating
- Tap on **Settings**
- Select Service mode and enter the code
- Select the **Update** button and use the arrow button to move all the way to the bottom

Mo.03.06.19 08:19

HARGASSNER

SOFTWARE UPDATE

Press and hold Save button
until boot loader has started

(ATTENTION: CONTROL UNIT RESTARTS!)

- Tap and hold the Save button
 - The bootloader will start
- Insert a storage card into the card slot

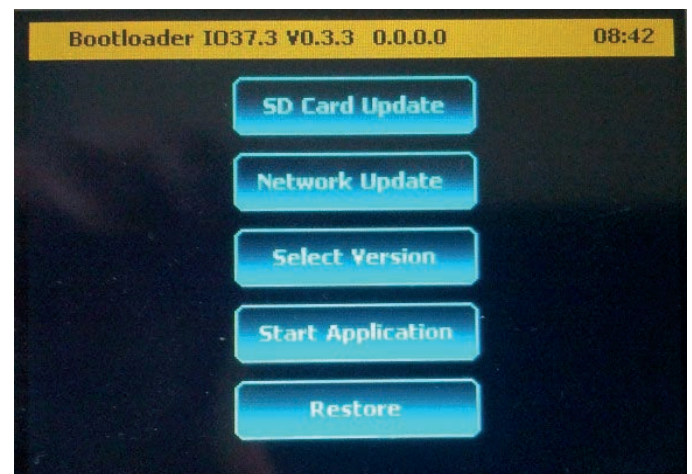

- Tap on "SD card update"
- Use the "Down" or "Up" button to select the correct software version
- Confirm your selection with "Enter"
- Start the software by tapping on the "Start application" button
 - The version you have selected will be loaded onto the control unit
- Remove the storage card

9 Calibrating the lambda sensor

- Connect the lambda sensor and put it in a safe place
 - The lambda sensor will get hot when it is connected
- Select Lambda sensor in service manual mode
- Tap on Start calibration
 - The calibration process will take 8 minutes
- If an error message appears, clean and calibrate the lambda sensor again
- If the error message is still displayed, replace the lambda sensor
- Reset the maintenance process when the calibration process has been completed
- Service manual mode no. 59

10 Test run

- Repeat the function test
 - ⇒ See „Service manual mode (function test)“ on page 4
 - All the moving parts should be checked before and after the maintenance process
- Switch on the boiler
- Start the flue gas measurement process
- Wait for your desired boiler temperature
- Tap on the boiler symbol and read the O₂ level on the BCE
- Compare the O₂ level with the value on the meter

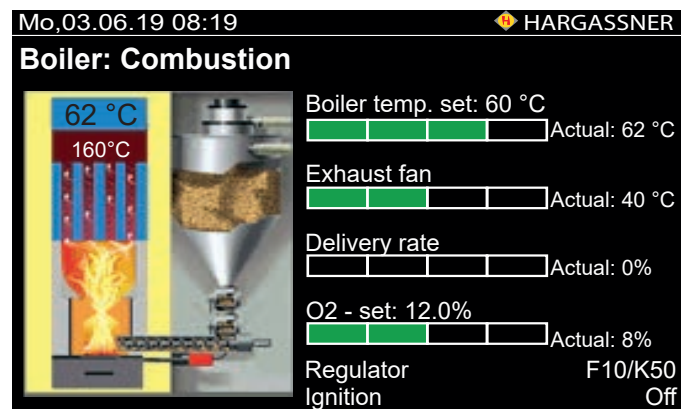

If no heat is required from the boiler, it can be heated using the test mode function

- Select Full load or Partial load
 - Message when the boiler temperature is reached
 - Check the hydraulics
 - Check the water pressure and pump settings
 - Check the back-end protection
- Talk to the customer again at the end of the maintenance process and issue a maintenance report and/or a test report
- Flue gas values and present defects
 - Technical safety defects depending on the country's regulations
 - Check the flue pipe insulation
 - Check the air supply openings

Chapter II: Lubrication plan

1 Lubricants

No.	Designation	Properties	Article number
1	Thermogleit (graphite spray)	Mechanical joints and screws that are exposed to heat	12333747
2	High-performance lubricant	Mechanical joints and screws that are not exposed to heat	11052895

2 Lubrication points

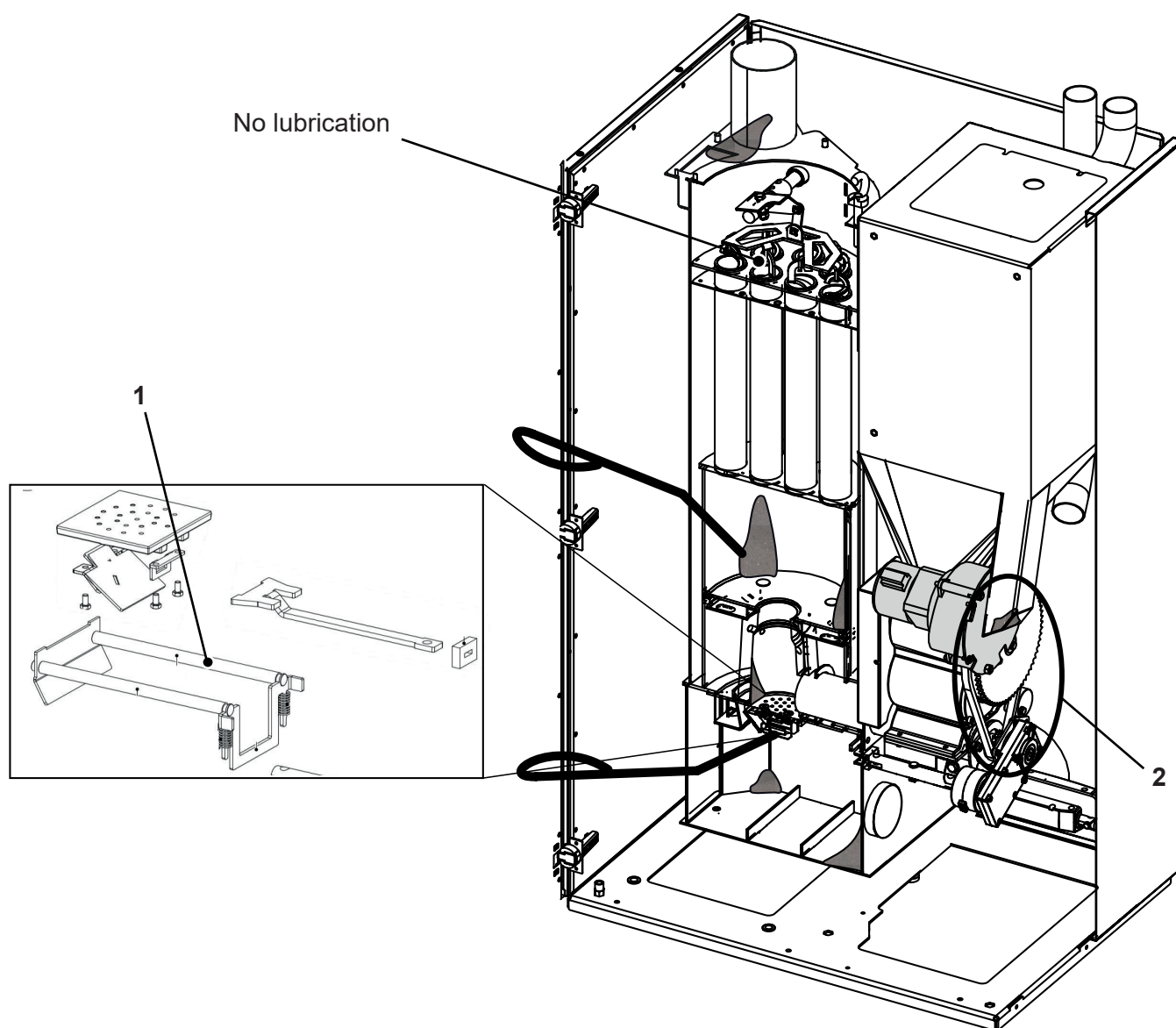

Chapter III: Advanced service tasks

1 Replacing the refractory stone

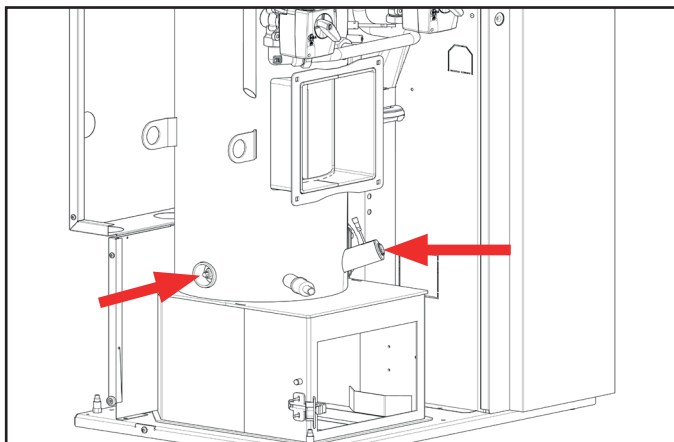

- Remove the cleaning lid
- Remove the ignition
- Loosen the screw in the refractory clamp

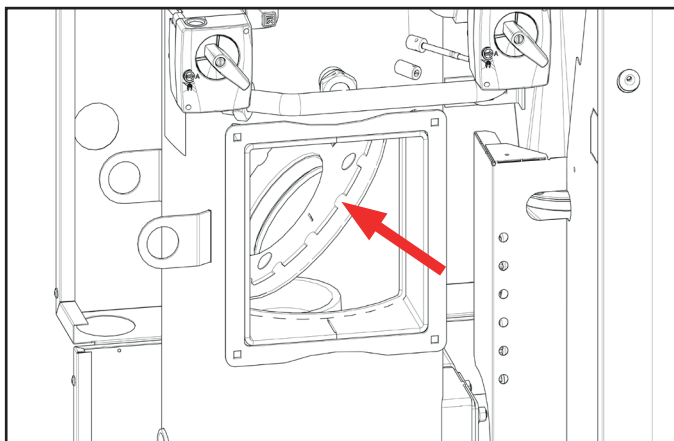

- Remove the combustion chamber cover

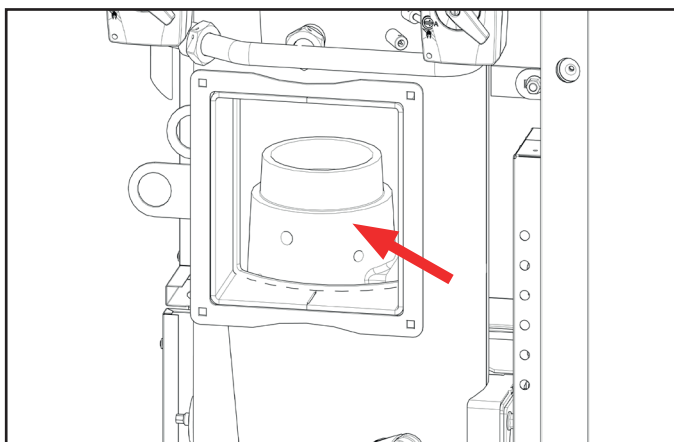

- Remove / Dispose of the refractory stone and seals
- Clean the sealing surfaces

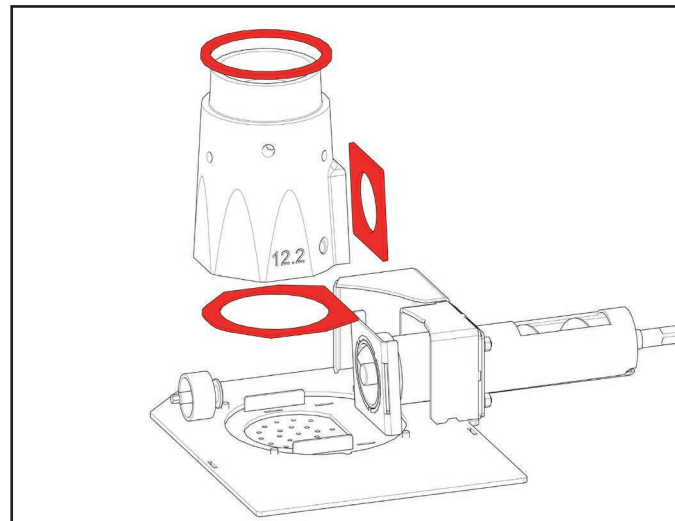

- Put the new refractory stone and seals in position
- Tighten the refractory clamp's clamping screw at 3 Nm
- Check that the refractory is seated securely (try to wiggle it) and put the other boiler components back in place

2 Replacing the pellet vacuum turbine's carbon brushes



□ Remove the (1) housing cover

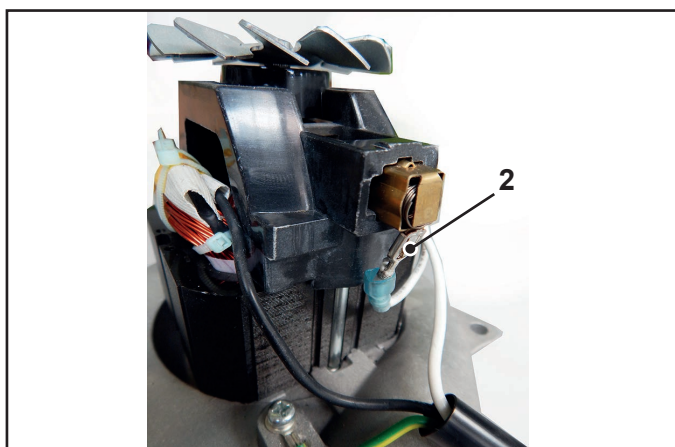

□ Take off the flat receptacle (2)

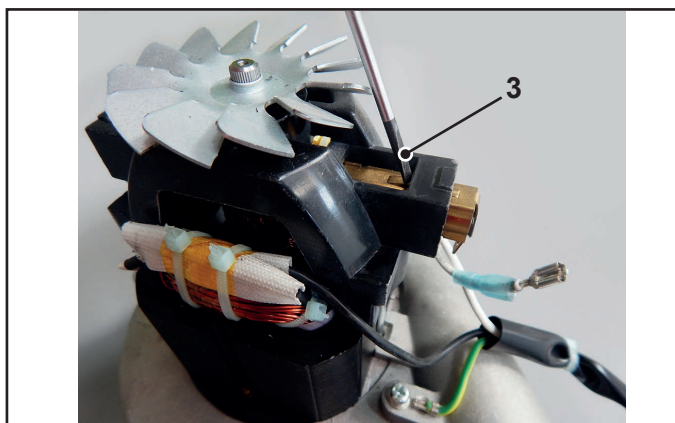

- Push in the leaf spring (3) on the housing of the carbon brush
- Pull out the carbon brush.
- Replace the two carbon brushes with new ones
- Put the components you have detached back together in reverse order
- Clean and check the housing
- Reset the vacuum turbine's meter after replacing the carbon brushes
- Service manual mode no. 59

Chapter IV: Parameters

1 Parameter list - Service

Software version V14.0I

Menu	Description	Default							
J	GSM	Nano-PK							
		6	9	10	12	15	20	25	32
J1	Waiting time - SMS alert	5 Min							
J2	GSM module - alarm - reset	No							
J3	Time to clear	10 Min							
J4	Auto Reset GSM	Auto Reset Yes							
J5	Warning via SMS	Yes							
K	Boiler	Nano-PK							
		6	9	10	12	15	20	25	32
K1	Combustion min. heat output	30 %							
K2	Minimum temperature	48 °C							
K2_P	Minimum temperature	40 °C				48 °C			
K3	Maximum temperature	78 °C							
K4	Test mode Set temperature	70 °C							
K4a	Test mode runtime	120 Min							
K5	Temperature - hysteresis	12 °C							
K6	Set temperature - superelevation	6 °C							
K7	Flue gas temperature - error below	65 °C							
K8	Time - flue gas temperature - error	15 Min							
K9	Fan follow-up time	15 Min							
K10	Exhaust fan minimum speed	0 %							
K11	Exhaust fan maximum speed	50 %	57 %	84 %		88 %			
K11a	Exhaust fan at 100% output	50 %	62 %	78 %		88 %	60 %	70 %	90 %
K12	Exh. fan at slumber mode	10 %							
K12a	Exhaust fan activated in slumber mode after lambda heating	120 Min							
K13	Exhaust fan max. at burn out	80 %							
K14	Slumber mode inlet temperature above BT max	2 K							
K14a	Slumber mode inlet temperature above BT max during a heat circuit reduction	-3 K							
K15	Slumber mode outlet above highest demand	2 K							
K20	Boiler locked at 2x slumber mode within	60 Min							
K20a	Duration - boiler locked at 2x slumber mode	60 Min							
K32	Test mode max. output	100 %							
K32a	Full load	50 %							
K40	Output limit during error	60 %							

Menu	Description	Default							
K48	Minimum exhaust fan speed during HV heat-up	40%							
K48a	Minimum exhaust fan speed during HV combustion	30%							
K48b	Minimum exhaust fan speed when HV door open	40%							
K50	Maximum demand HKR	0 Sec							
K56	Maximum demand HKR	75 °C							
K57	Number of boiler starts within 24 hrs below min. runtime until warning	20x							
K60	Exhaust fan in boiler Off when FGTM activated	0%							
L	Pumps / Return	Nano-PK							
		6	9	10	12	15	20	25	32
L1	Heat circuit pump 1 release difference	3 °C							
L2	Heat circuit pump 2 release difference	2 °C							
L2a	Heat circuit pump 3 release difference	3 °C							
L2b	Heat circuit pump 4 release difference	2 °C							
L2c	Heat circuit pump 5 release difference	3 °C							
L2d	Heat circuit pump 6 release difference	2 °C							
L2e	Heat circuit pump A release difference	2 °C							
L2f	Heat circuit pump B release difference	2 °C							
L3	Release temperature for all HWTs	50 °C							
L4	AT overrun time	5 Min							
L5	External heat circuits Release temperature	50 °C							
L6	HWT pump 1 release temperature	62 °C							
L7	HWT pump 2 release temperature	63 °C							
L7a	HWT pump 3 release temperature	62 °C							
L7b	HWT pump A release temperature	62 °C							
L7c	HWT pump B release temperature	62 °C							
L8	RL bypass pump on below	54 °C							
L9	RL bypass pump off below	66 °C							
L10	Return minimum	35 °C			32°C	36°C	33°C	30 °C	
L10_P	Return minimum	30 °C				36°C	33°C	30 °C	
L10a	Return maximum	7	10	13	13	16	10	13	16
L10a_P	Return maximum	7	10	8	8	10	8	10	12

Menu	Description	Default
L10b	Spreading Auto-adjust range	5
L10c	Interval RL-Adaption	5 Min
L10d	Minimum heat differential	3.0 °C
L11	Back-end protection error below	30 °C
L11_P	Back-end protection error below	28 °C
L11a	Time for error back-end protection	60 Min
L11b	Return mixer interval	10 Sec
L11c	Return mixer readjust time	15 Sec
L11d	Minimum mixer runtime	0.5 Sec
L11e	Open return mixer at first startup	40 %
L11f	RL-Autoadapt at HWS loading	active
L12	District line pump 1 Release temperature	58 °C
L12a	Controlled district line pump Release temperature	59 °C
L13	Heat circuit pump 1 Release temperature	30 °C
L13a	Heat circuit pump 1 release temperature without return mixer	60 °C
L14	Heat circuit pump 2 Release temperature	31 °C
L14a	Heat circuit pump 2 release temperature without return mixer	61 °C
L15	Heat circuit pump 3 Release temperature	32 °C
L15a	Heat circuit pump 3 release temperature without return mixer	62 °C
L16	Heat circuit pump 4 Release temperature	33 °C
L16a	Heat circuit pump 4 release temperature without return mixer	63 °C
L17	Heat circuit pump 5 Release temperature	32 °C
L17a	Heat circuit pump 5 release temperature without return mixer	62 °C
L18	Heat circuit pump 6 Release temperature	33 °C
L18a	Heat circuit pump 6 release temperature without return mixer	63 °C
L19	Heat circuit pump A Release temperature	30 °C
L19aa	Heat circuit pump A release temperature without return mixer	60 °C
L19a	Heat circuit pump B Release temperature	30 °C
L19ab	Heat circuit pump B release temperature without return mixer	60 °C

Menu	Description	Default							
L20	External heat circuits Release temperature	34 °C							
L20a	External heat circuits release temperature without return mixer	64 °C							
L51	Return Controller - accumulator 3F/5F Kp	0.7							
L52	Return Controller - accumulator 3F/5F Tn	300 sec							
L53	Return -controller - accumulator 3F/5F Tv	125 sec							
L54	Return Controller accumulator 3F/5F T1	125							
L55	Return Controller - output minimum	30 %							
M	Heat circuit	Nano-PK							
		6	9	10	12	15	20	25	32
M1	All heat circuits Heat circuit pumps on above boiler temperature	84 °C							
M1a	All heat circuits Outside temperature for safety circuit	-10 °C							
M2	All heat circuits Residual heat until boiler below	36 °C							
M2a	All heat circuits	Residual heat several times							
M3	All heat circuits Boiler superelevation according to flow temperature	5 °C							
M4	Heat circuit 1 Factor - room influence Remote control	1							
M5	Heat circuit 2 Factor - room influence Remote control	1							
M5a	Heat circuit 3 Factor - room influence Remote control	1							
M5b	Heat circuit 4 Factor - room influence Remote control	1							
M5c	Heat circuit 5 Factor - room influence Remote control	1							
M5d	Heat circuit 6 Factor - room influence Remote control	1							
M5e	Heat circuit A Factor - room influence Remote control	1							
M5f	Heat circuit B Factor - room influence Remote control	1							
M6	All heat circuits Superelevation room temperature Room controller	1.0 °C							
M6a	All heat circuits Hysteresis room temperature Room controller	0.0 °C							
M7	All heat circuits Reduction delay	15 Min							
M8	Heat circuit 1 Minimum mixer runtime	0.3 sec							
M9	Heat circuit 2 Minimum mixer runtime	0.3 sec							

Menu	Description	Default							
M9a	Heat circuit 3 Minimum mixer runtime	0.3 sec							
M9b	Heat circuit 4 Minimum mixer runtime	0.3 sec							
M9c	Heat circuit 5 Minimum mixer runtime	0.3 sec							
M9d	Heat circuit 6 Minimum mixer runtime	0.3 sec							
M9e	Heat circuit A Minimum mixer runtime	0.3 sec							
M9f	Heat circuit B Minimum mixer runtime	0.3 sec							
M10	External HC	without outside temperature							
M10a	External heat circuit temperature at a voltage of 0 V	0 °C							
M10b	External heat circuit temperature at a voltage of 10 V	100 °C							
M10c	Maximum permitted analogue input temperature	75 °C							
M11	All heat circuits Proportional coefficient	100 %							
M12	All heat circuits Differential temperature for mixer	0.1 °C							
M14	Controlled district line Differential temperature for mixer	1.0 °C							
M15	Controlled district line Minimum mixer runtime	0.3 sec							
M16	Error detection - mixer/pump	not activated							
M21	Open all heat circuits HC mixer at first start-up	15 %							
M79	All heat circuits - heat circuit accumulation	Off							
M80	All heat circuits - time for correction of set flow in combustion and slumber mode	30 Min							
M81	All heat circuits - correction of set flow (+/-)	2 K							
M82	All heat circuits - correction of set flow when output is below	90%							
M83	All heat circuits - hysteresis below BT max for correction of set flow	5 K							
N	HWT	Nano-PK							
		6	9	10	12	15	20	25	32
N1	HWT pump on when boiler temperature above	83 °C							
N2	Differential temperature for HWT pump	1 °C							
N3	HWT priority - factor	10							

Menu	Description	Default
N4	HWT pump - post-run - residual heat	5 °C
N5	Boiler superelevation Legionella protection	5 °C
N6	All HWTs	Residual heat several times
N7	Boiler superelevation during HWT loading	10 °C
N10	HWT priority controller KP (output)	0.5
N11	HWT priority controller TN (output)	50.0 Sec
N12	HWT priority controller KP (THWT)	10
N13	HWT priority controller TN (THWT)	1000.0 Sec
N14	HWS hysteresis at accumulator	5 °C
N15	All HWTs - info "HWT is not reaching accumulator temperature" after	2 hrs
O	Accumulator + External heat	Nano-PK
		6 9 10 12 15 20 25 32
O1-Set	Superelevation - heat circuit set temperature	5 °C
O2	Hysteresis - heat circuit set temperature	5 °C
O3-Set	Superelevation - HWT temperature	5 °C
O4	Hysteresis - HWT temperature	1 °C
O5	Base temperature boiler - accumulator	38 °C
O6	Differential temperature	5 °C
O7	Accumulator pump on BT-differential	5 °C
O9	HWT difference control	On
O10	External heat Switch-on temperature	60 °C
O11	External heat Heat differential	2 °C
O12	External heat Lock time	15 Min
O13	Accumulator Residual heat until boiler temperature below	65 °C
O30	Outlet temperature - superelevation - shutdown - pump	12 °C
O31	Outlet temperature - hysteresis	6 °C
O32-Set	Control - PWM pump - minimum	25 %
O33	Control - PWM pump - maximum	95 %
O33a	Control - PWM pump - maximum	90 %
O33b	Pump-cycle duration at minimum output	5 sec
O34	Accumulator loading - superelevation - demand FWS	5 °C
O35-Set	Accumulator loading - hysteresis FWS	5 °C
O36	Interpolation factor	3

Menu	Description	Default							
O36a	Pump starting output scaling	1							
O36b	Pump starting output scaling	0.85							
O43-Set	I_AntiWindUp	2.5							
O43a	I_AntiWindUp	2.5							
O44	D_MaxFilterFrame	8							
O46 - O49-Set	Fresh-water station See fresh-water station instructions								
P	Ignition	Nano-PK							
		6	9	10	12	15	20	25	32
P1	Time for changeover combustion	240 Sec							
P2	Downtime, no ignition	0 Min							
P2a	Downtime flue gas temp. increase	30 Min							
P3	Flue gas temperature no ignition	120 °C							
P4	Exh. fan on ignition	90 %				60 %	70 %		
P4a	Exhaust fan start value	25 %							
P4b	Exhaust fan start-up time	30 Sec							
P5	Flue gas temperature increase	8 °C				14 °C			
P7	Ignition monitoring stoker input time	340 sec	340 sec		220 sec	220 sec	320 sec	265 sec	215 sec
P7a	Ignition monitoring stoker input time	200Sec							
P7b	Ignition monitoring - amount of input	185 g				450 g			
P8	Max. feeding amount	90 %		75 %					
P8a	Ignition on before ignition fuel quantity is reached	0 Sec							
P9	Ignition monitoring blind time - lambda sensor	90 Sec							
P11	Ignition attempt time	15 Min							
P12	Warm up time lambda sensor	90 Sec							
P12a	Heat-up time lambda sensor Bosch	180 Sec							
P13	O2 changeover combustion	18 %							
P14	Ignition attempts	2							
Q	De-ash	Nano-PK							
		6	9	10	12	15	20	25	32
Q0	De-ash - ash motor	Not available							
Q0a	Max. torque ash auger	55 Nm							
Q0b	Speed ash auger	2.0 rpm							
Q1	De-ash at the earliest after	60 Min							
Q2	De-ash at the latest after	240 Min							
Q3	De-ash Minimum burnout time	10 Min							
Q3a	De-ash Maximum burnout time	30 Min							
Q3b	De-ashing O2 burnout average completed	20.00 %							

Menu	Description	Default	
Q3c	Number of burnouts with maximum time before warning	3	
Q4	Exhaust fan min. at follow up	40 %	
Q4a	Exhaust fan at de-ash	10 %	
Q5	De-ash motor strokes	2	
Q6	Prewarning grate current from	1.1 A	
Q7	De-ash max. motor current Sliding grate	1.7 A	
Q8	De-ash runtime for 3/4 opening	6 Sec	8 Sec
Q9	De-ash - ash auger runtime	30 Sec	750 Sec
Q10	De-ash - warning motor current ash auger	120 mA	
Q11	De-ash - maximum motor current ash auger	140 mA	
Q11a	De-ash - ash motor reverse run time	5 Sec	
Q11b	De-ash Ash motor number - return runs	3x	5x
Q12	Cleaning - Device after de-ash	1x	
Q13	Cleaning - run time cleaning rod	20 Sec	
Q14	Cleaning - max. motor current cleaning rod	5.0 A	
Q20	De-ash - ash motor in combustion interval	30 Min	
Q21	De-ash - ash motor in combustion switch on time	10 Sec	0 Sec
Q30	Cleaning - cleaning rod pulse duration	1.0 Sec	
Q31	Cleaning - cleaning rod pulse pause	1.0 Sec	
Q32	De-ash cleaning device - number of pulses	5	
Q33	De-ash relating to number of ignitions	0	
Q34	Nano-PK Plus flushing after number of cleans	3x	
Q35	Nano-PK Plus flushing duration	25 Sec	
Q35a	Nano-PK Plus flushing duration preventive measure	10 Sec	
Q36	Nano-PK Plus min. temperature drop after flushing	10K	
Q37	Nano-PK Plus temperature drop after flushing not reached, warning after	5x	
Q38	Nano-PK Plus temperature drop after flushing not reached, error after	10x	
Q39	Nano-PK Plus min. temperature increase after flushing	10 K	
Q40	Nano-PK Plus no temperature increase after flushing, warning after	30 Min	
Q41	Nano-PK Plus no temperature increase after flushing, error after	60 Min	

Menu	Description	Default							
Q42	Nano-PK Plus - Nano-PK Plus drying (only when firing is off)	ACTIVATED							
Q42a	Nano-PK Plus exhaust fan during drying	80 %							
Q42b	NANO-PK Plus drying runtime	60 Min							
Q43	Nano-PK Plus flushing interval for preventive measure after	7 days							
Q44	Nano-PK Plus temperature change during boiler start after firing Off/ Manual/Off	1 K							
Q45	Nano-PK Plus flushing release	Release cleaning							
Q80	De-ash ABS function - boiler	active							
R	Stoker / room extraction	Nano-PK							
		6	9	10	12	15	20	25	32
R0	Stoker motor	Step motor IO49				BLDC IO49			
R0b	Stoker motor SPG	15 W							
R0c	Extraction auger - motor fuel extraction	RA 230V (DRM)							
R1	Stoker - stepper/BLDC max. torque	55 Nm				77 Nm			
R1a	Stoker - stepper/BLDC min. speed prior to pulsing	0.33 rpm				0.8 rpm			
R1b	Stoker - stepper/BLDC max. speed	2.0 rpm				2.7 rpm			
R1c	Stoker - asynchronous/BLDC maximum motor current	120 mA				600 mA			
R1d	Stoker - asynchronous maximum motor current 25W	120 mA							
R1e	Stoker - asynchronous current filter	50 %							
R1f	Stoker - stepper/BLDC current connection recognition	30 mA				5 mA			
R2	Stoker - reverse run time	10 Sec				5 Sec			
R3	Stoker - asynchronous stoker cycle	5 Sec							
R4	Stoker - min. fuel transport amount	0.00 %							
R4a	Stoker stepper/BLDC - current scale stoker	55 %	65 %	100 %					
R5	Stoker maximum delivery rate without lambda sensor	70 %	75 %	50 %	65 %				
R7	Stoker stepper - minimum deviation current consumption	1 %							
R7a	Stoker stepper - time minimum deviation current consumption	60 Sec							
R7b	Stoker stepper stall guard offset	0							
R7c	Stoker blockage reset timer	5 Min							
R7d	Stoker BLDC threshold speed deviation	15 %							
R7e	Stoker - attempts to remove a blockage (0 = unlimited attempts)	0							
R8	Stoker stepper/BLDC - delivery rate	33.5 g/U				42.0 g/U			

Menu	Description	Default			
R8a	Stoker stepper/BLDC - delivery rate consumption display	38 g/U			
R9	Stoker - asynchronous delivery rate [kg/h]	6.4			
R9a	Consumption display - Warning at reached amount of	1000 kg			
R9b	Stoker - clean combustion chamber warning after pellet consumption	3.5 t	8.0 t		
R9c	Stoker - clean combustion chamber warning after exhaust fan runtime	8760 h			
R10	Extraction auger RAS nominal motor current	2.0 A			
R11	Extraction auger RAS maximum motor current	3.2 A			
R12	Extraction auger - return time RAS+RAD	1 Sec			
R12a	Extraction auger number of return runs	1 x			
R13	Extraction auger - fuel delivery rate RAS+RAD	100 %			
R14	Extraction auger delay at suction	5 Sec			
R15	Automatic filling - max. ST auger runtime for suction	320 Min	360 Min	300 Min	240 Min
R20	RAS filling min. stoker auger runtime for suction	60 Min			
R21	Fill RAS - max. fill time	15 Min	20 Min		
R21a	RAS filling - maximum filling time Schellinger				
R22	RAS filling - post-run time vacuum turbine	15 Sec			
R22a	RAS filling - backward running after suction - activation only in combination with freewheel clutch RAS	0.0 Sec			
R22b	RAS filling Schellinger Classic suction turbine follow-up time	10 Sec			
R22c	RAS filling Schellinger E3 suction turbine follow-up time	20 Sec			
R23	Fill RAS - exhaust fan speed at filling	70 %			
R24	Fill RAS - delay indication limiter	2 Sec			
R25	Auto change unit - max. suction time	10 Min			
R26	AUP Threshold stall detection	60 %			
R27	Auto change unit - min. speed	0.3			
R27a	Changeover unit Pos.1 Set	2.5 mm			
R27b	Changeover unit Pos.2 Set	67.5 mm			
R27c	Changeover unit Pos.3 Set	132.5 mm			
R27d	Changeover unit Pos.4 Set	197.5 mm			
R27e	Changeover unit Pos.5 Set	262.5 mm			

Menu	Description	Default							
R27f	Changeover unit Pos.6 Set	327.5 mm							
R27g	Changeover unit Pos.7 Set	392.5 mm							
R27h	Changeover unit Pos.8 Set	457.5 mm							
R28a	Changeover unit Pos.1 Set	6 mm							
R28b	Changeover unit Pos.2 Set	71 mm							
R28c	Changeover unit Pos.3 Set	136 mm							
R28d	Changeover unit Pos.4 Set	198 mm							
R29a	Changeover unit length of AUP 2 positions	135.0 mm							
R29b	Changeover unit length of AUP 3 positions	135.0 mm							
R29c	Changeover unit length of AUP 4 positions	200.0 mm							
R29d	Changeover unit length of AUP 6 positions	330.0 mm							
R29e	Changeover unit length of AUP 8 positions	460.0 mm							
R30	Extraction auger RAD nominal motor current	0.75 A							
R31	Extraction auger RAD maximum motor current	1.6 A							
R32	Fill RAD - max. fill time	10 Min							
R33	Fill RAD - follow up time extraction auger	15 Sec							
R34	Fill RAD - delay indication limiter	5 Sec							
R35	Mole Schellinger Mole Schellinger trigger time Classic	120 Sec							
R35a	Mole Schellinger Mole Schellinger break time Classic	5 Sec							
R35b	Mole Schellinger Schellinger trigger time E3	60 Sec							
R35c	Mole Schellinger break time E3	15 Sec							
R38	Extraction auger connection monitoring of FE	Yes							
R38a	Extraction auger connection monitoring of FE 2	Yes							
R40	Extraction auger 3-phase nominal motor current	1.2 A							
R41	Extraction auger 3-phase maximum motor current	2.5 A							
S	Lambda sensor	Nano-PK							
		6	9	10	12	15	20	25	32
S1	O2-Set value	7.50 %					7.00 %		
S1a	O2 set value air independent	7.50 %					7.00 %		
S1b	Test mode O2-Set value	7.50 %							
S2	O2-stop difference	3.00 %							
S2a	Time for O2-error	13 Min							
S3	O2 increase partial load	1.00 %					2.00 %		
S4	O2 reduction above	17.00 %							

Menu	Description	Default							
S5	Time for O2-reduction	5 Min							
S7	Lambda sensor	NGK							
S8	Lambda sensor correction	0.0 mV							
S9	Exhaust fan during lambda calibration	20 %							
S10	O2 stop hysteresis	1.00 %							
S11	Reduction BrstReg. O2 Stop	10 %							
S12	Set output - lambda heating	8.0 W							
S30	O2 warning when set level has not been reached after	60 Min							
T	Control	Nano-PK							
		6	9	10	12	15	20	25	32
T1	Flue gas temperature - minimum	75 °C							
T2	Flue gas temperature - maximum	200 °C							
T3	Combustion - maximum heat output	100 %							
T4	Ventilator output correction	0 %							
T4a	Ventilator output correction air independent	0 %							
T4b	Ventilator correction test mode	0 %							
T5	Flue gas temperature correction	25 °C							
T6	Fuel correction	50							
T7	Fuel correction controller ymax.	100							
T8	Fuel correction controller ymin.	10							
T9	Fuel correction controller Kp	0.05							
T10	Fuel correction controller Tn	1000.0 Sec							
T11	Boiler temperature - controller Kp	4							
T12	Boiler temperature - controller Tn	600.0 sec							
T13	Boiler temperature - controller Tv	90.0 sec							
T14	Boiler temperature - controller T1	100							
T15	Boiler temperature - controller z	0							
T16	Boiler temperature - controller xw_exp	1.5							
T17	Flue gas temperature - limiter Kp	1							
T18	Flue gas temperature - limiter Tn	250.0 sec							
T19	O2 fuel controller Kp	1							
T20	O2 fuel controller Tn	100.0 Sec							
T21	O2 fuel controller Tau	600.0 Sec							
T22	O2 delay	0.05							
T50	Maximum runtime in manual mode	2 Min							
T60	RL bypass pump controller Kp	4							
T61	RL bypass pump controller Tn	100							
T70	Exhaust fan drive	BLDC IO49							
T70a	Exhaust fan diameter	150 mm				180 mm			
T72	Exhaust fan max. speed	3600							
T72a	Exhaust fan min. speed	10 %							
T73	Exhaust fan Kp	65							
T74	Exhaust fan Tn	30 sec							

Menu	Description	Default							
T54	Exhaust fan - speed - tolerance	15 %							
T75a	Exhaust fan error after	90 Sec							
T76	Exhaust fan pulse per round	1							
T77	Exhaust fan max. current exhaust fan BLDC IO49 150mm	6							
T77a	Exhaust fan max. current exhaust fan BLDC IO49 180mm	8							
T78	Exhaust fan start mode	Normal							
W	Maintenance	Nano-PK							
		6	9	10	12	15	20	25	32
W1	Warning for service	No							
W3	Warning for full-load hours	2000 h							
W4	Warning for heating hours	4000 h							
W5	Warning from	01.01.2017 01:00:00							
W7	Service from	01.02.2017 01:00:00							
W8	Service until	30.11.2017 01:00:00							
W9	Warning for boiler starts	3000 x							
z	Special features	Nano-PK							
		6	9	10	12	15	20	25	32
Z0	Boiler type overview	Nano.2 (.3)							
Z1	Boiler type	6	9	10	12	15	20	25	32
Z1a	Hopper Manual refill	No							
Z1b	Timeout Loxone	30 Sec							
Z1c	IO-X10-104 extension control board 1	Not available							
Z1d	IO-X10-104 extension control board 2 (S3:1)	Not available							
Z1da	DAQ output - sensor board 2	No selection							
Z1e	Nano-PK Plus	No							
Z1f	MWZ03 DAQ channels	Not available							
Z1g	Addressing	Secondary address							
Z1h	Baud rate	2400							
Z8	Commission no.	0							
Z9a	Delete error list	No							
Z9b	Clear infos	No							
	Error memory	Nano-PK							
		6	9	10	12	15	20	25	32
AE211	ErrorCodes	No selection							

Your expert for **PELLET** | **WOOD LOG** | **WOOD CHIP** HEATING

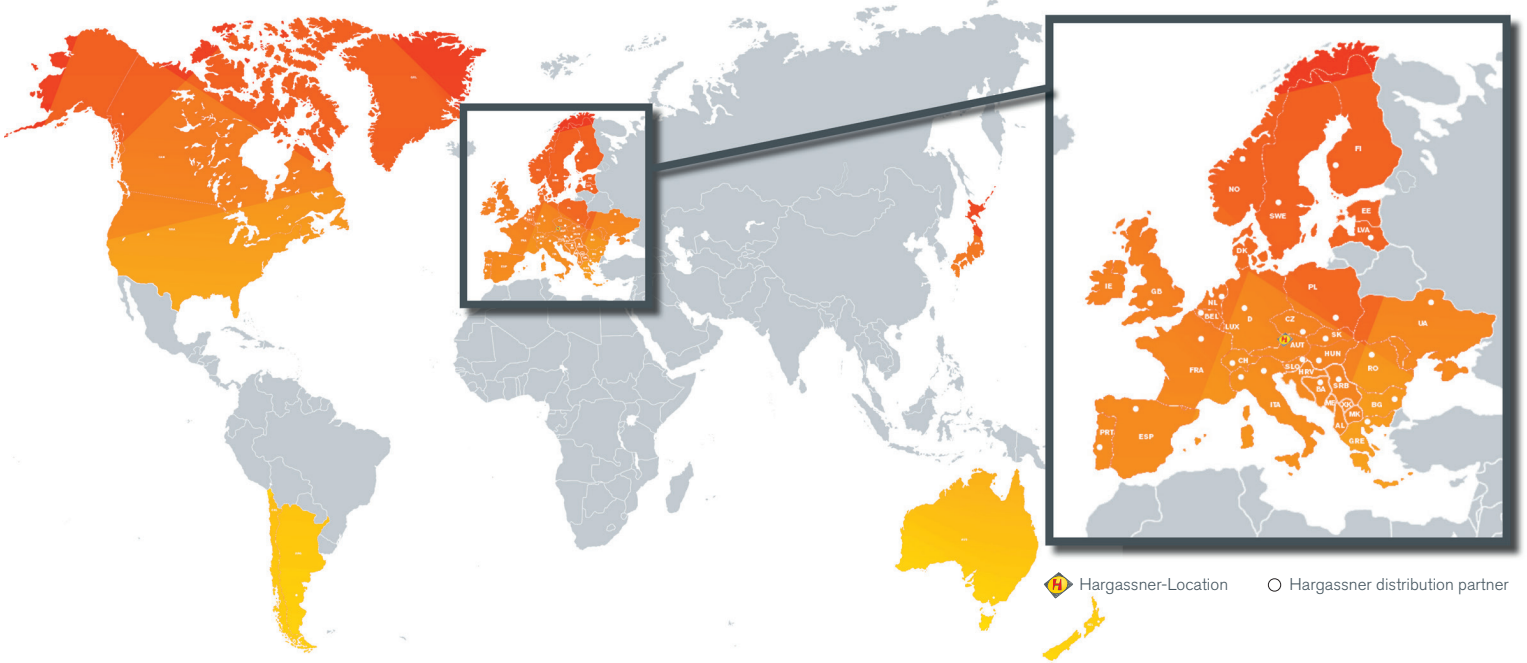

hargassner.com

AUSTRIA

HARGASSNER Ges mbH

Anton Hargassner Strasse 1
A-4952 Weng
Tel. +43 (0) 77 23 / 52 74
Fax +43 (0) 77 23 / 52 74 - 5
office@hargassner.at

GERMANY

HARGASSNER DE GmbH

Heraklithstraße 10a
D-84359 Simbach/Inn
Tel. +43 (0) 77 23 / 52 74
Fax +43 (0) 77 23 / 52 74 - 5