

# Installation manual Pellet Boiler Nano-PK 6-15

**HARGASSNER**  
HEIZTECHNIK DER ZUKUNFT



**Follow and store this manual**

**HARGASSNER Ges mbH**

A 4952 Weng, Upper Austria  
Tel.: +43/7723/5274-0  
Fax.: +43/7723/5274-5  
office@hargassner.at  
www.hargassner.com

EN - V08 10/2024 - 11059259

# Contents

---

<b>1 General</b> .....	<b>4</b>
<b>2 Transport</b> .....	<b>5</b>
2.1 Transport weight .....	5
2.2 Place of installation .....	5
2.3 Space requirements of the system, operating area .....	5
<b>3 Installation dimensions</b> .....	<b>6</b>
3.1 Dimensioning .....	6
3.2 Technical Data .....	8
3.3 Flue pipe connection at rear or side .....	9
3.4 Flue connection set AIO Ø 100 mm (item no.: 7110917) .....	10
3.5 Flue connection set ADO Ø 100 mm (item no.: 7110916) .....	11
3.6 Flue connection set AIO Ø 130 mm (item no.: 7113917) .....	12
3.7 Flue connection set ADO Ø 130 mm (item no.: 7113916) .....	13
<b>4 Scope of delivery overview</b> .....	<b>14</b>
<b>5 Unloading the system</b> .....	<b>15</b>
5.1 Disassembling the upper maintenance lid .....	15
<b>6 Setup</b> .....	<b>16</b>
6.1 Reducing the transport dimensions .....	18
<b>7 Fitting the levelling feet</b> .....	<b>22</b>
<b>8 Adjusting the cover</b> .....	<b>23</b>
8.1 Adjusting the cover door .....	23
8.2 Removing the cover door .....	24
<b>9 Mounting instructions for pellet hoses and pellet steel pipes</b> ..	<b>25</b>
9.1 Earthing the pellet hoses .....	25
9.2 Marking the pellet hoses .....	26
9.3 Laying pellet hoses .....	28
9.4 Accessories for pellet hoses and pellet steel pipes .....	30
<b>10 Design of the fuel storage room</b> .....	<b>31</b>
10.1 Pellet storage room ventilation .....	31
10.2 Safety in the fuel storage room .....	32
<b>11 Facilities on site</b> .....	<b>33</b>
11.1 Country-specific regulations .....	33
11.2 Qualification of installation staff .....	33
11.3 Fire extinguisher .....	33
11.4 Designs of the installation space .....	33
11.5 Designs of the boiler room .....	34
11.6 Ventilation of the boiler room (for systems without AIO) .....	35
11.7 Air-independent operation (AIO) .....	35
11.8 Flue connection, flue pipe .....	36
11.9 Flue draught stabiliser .....	37
<b>12 Hydraulic installations</b> .....	<b>38</b>
12.1 Domestic hot water mixer .....	38
12.2 Internal hydraulic module extensions .....	39

12.3 Safety group . . . . .	40
<b>13 Electrical installations . . . . .</b>	<b>41</b>
13.1 Cable installation . . . . .	41
<b>14 Sensor installation . . . . .</b>	<b>42</b>
14.1 Outdoor sensor . . . . .	42
14.2 Flow, accumulator and external heat sensors . . . . .	42
<b>15 Remote control FR25 / FR35 / FR40 . . . . .</b>	<b>44</b>
15.1 FR25 remote control (analogue) . . . . .	44
15.2 FR35 remote control (digital) . . . . .	44
15.3 FR40 remote control (digital) . . . . .	44
<b>16 Extension module, board or controller. . . . .</b>	<b>45</b>
16.1 Heat circuit modules 1, 2 . . . . .	45
16.2 Additional board I/O 36 (HC AB/F, 5-sensor accumulator or differential controller) . . . . .	45
16.3 Heat circuit controller HKR. . . . .	45
<b>17 Permits and reporting requirements. . . . .</b>	<b>45</b>
<b>18 Commissioning the system . . . . .</b>	<b>45</b>

# 1 General

This installation manual is part of the system's operating manual.



## DANGER

### Danger to life

**Non-observance of the safety instructions may lead to death, injuries and damage**

- Observe the safety instructions attached to the system and in the manual.
- The activities described may only be carried out by assembly personnel trained by Hargassner.



## DANGER

### Danger to life

**Risk of death, injuries and damage due to incorrect design of the boiler room and fuel storage room**

#### Installation space

- Execution according to the local fire protection regulations.
- Ensure fire-safe, level and firm floor condition.
- Ensure there is a sufficient supply of combustion air that meets local regulations.
- Ensure weatherproof and frost-proof design.
- Observe the load-bearing capacity of the foundations. Weight of the system.

#### Fuel storage room

- Observe static requirements. Weight of the quantity of fuel stored.
- Ensure weatherproof and frost-proof design.
- Ensure dust-tightness.
- Ensure easy access and easy refill of the fuel storage room.
- Install safety devices in accordance with local regulations.
- Attach safety instructions near the access.

## 2 Transport

### 2.1 Transport weight

The system is delivered on pallets in individually packaged units.

Nano-PK 6-15	Weight
Pallet with boiler depending on version	Approx. 250 kg

#### Unloading, inspection and damage report

- Unload system
- Remove packaging
- Dispose of packaging in accordance with the Waste Disposal Act
  - ☞ Recycling materials can be recycled in a separated and cleaned state
- Check the system for transport damage
- Check that the delivery is complete
  - ⇒ See "Scope of delivery overview" on page 14.
  - ☞ Record any incompleteness of the delivery immediately in writing and send a report to Hargassner Ges mbH
  - ☞ Record any transport damage immediately in writing, take photographs and send a report to Hargassner Ges mbH
  - ☞ If the transport company is at fault, the complaint must also be noted on the shipping documents

### 2.2 Place of installation

⇒ See "Designs of the boiler room" on page 34.

#### Conditions

- Sufficient light
- Ensure fireproof, level and solid floor and ceiling construction
- Free of disturbing electrical installations and pipes

### 2.3 Space requirements of the system, operating area

- See data sheet or individual customer drawing
- Observe minimum distances and space requirements
- Drawing of the installation dimensions
- Leave a gap of 600 mm for access to the chimney

Description	Nano-PK 6-15
Room height	min. 180 cm

### 3 Installation dimensions

#### 3.1 Dimensioning

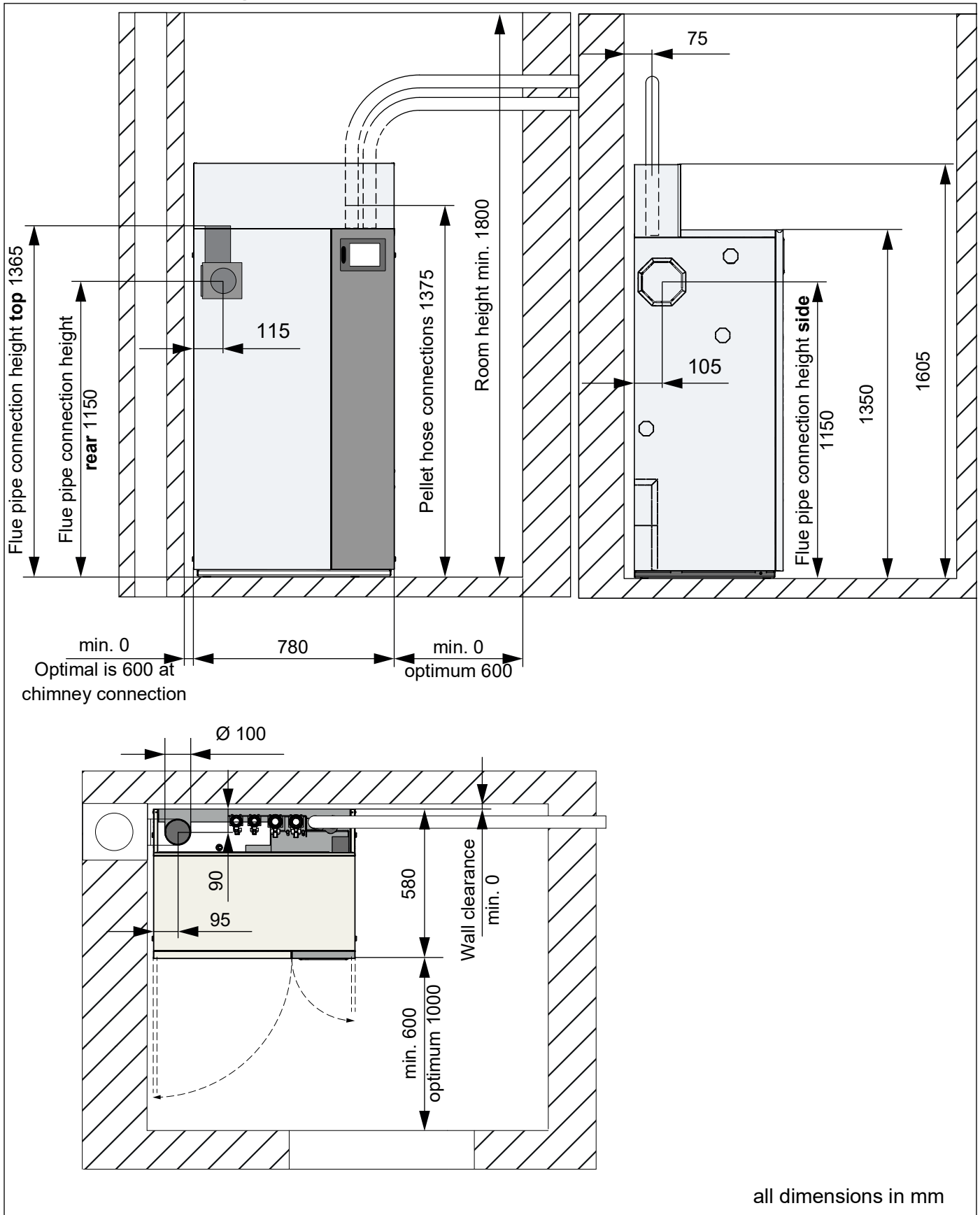

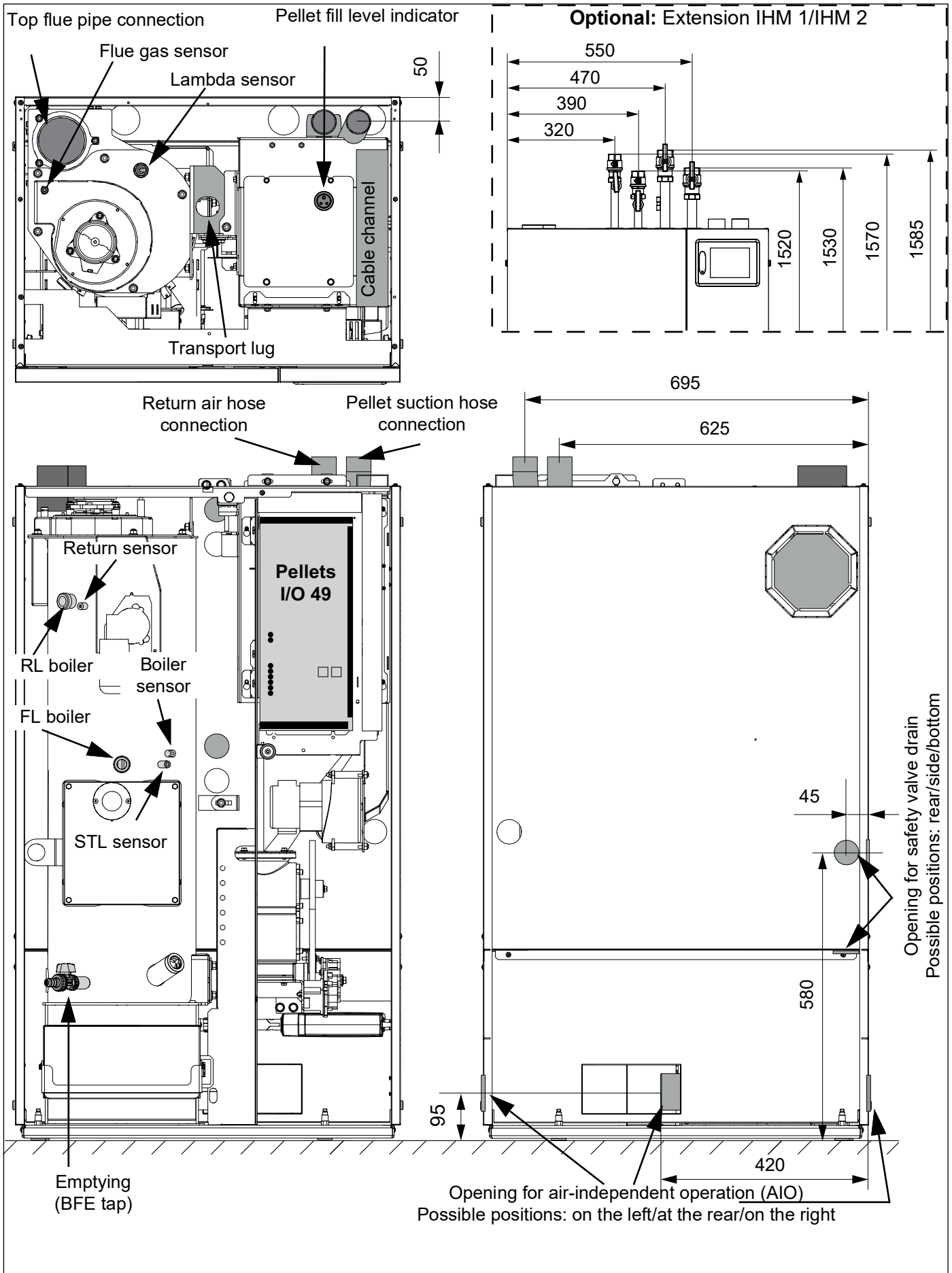

## 3.2 Technical Data

Designation	Unit	Nano-PK 6	Nano-PK9	Nano-PK10	Nano-PK12	Nano-PK15
Nominal heat output (output range)	KW	1.8 - 6.6	2.7 - 9.0	3.2 - 10.5	3.6 - 12.0	4.5 - 15.0
Fuel heat output	KW	7.0	9.5	11.1	12.6	15.8
Efficiency at nominal load	%	94.7	94.8	94.9	94.9	94.9
Efficiency at partial load	%	94.7	94.7	94.7	94.9	95.3
Boiler class (EN 303-5:2012)		5				
Fuel and fuel classification (EN 17225-2)		Wood pellets (A1)				
Boiler height	mm	1350				
Boiler width	mm	780				
Boiler depth	mm	580				
Transport dimensions HxWxD	mm	1380x780x580				
Flow and return (boiler)	inches	1				
Emptying	inches	1/2 IT				
Ø pellet hose connection	mm	50				
Pellet suction hose height	mm	1375				
Return air height	mm	1375				
Permissible operating pressure	bar	3				
Max. operating temperature	°C	85				
Water content	litres	24				
Weight	kg	220				
Required delivery pressure (available delivery pressure during AIO operation)	Pa	2 (5)				
Flue draft max. limit	Pa	10				
Flue pipe diameter	mm	100				
Flue gas temperature	°C	130				
CO <sub>2</sub>	%	14				
Mass flow rate	kg/sec	0.0037	0.0050	0.0058	0.0066	0.0083
Water-side resistance dT 10°	mbar	6.0	8.2	10.3	12.5	16.8
Water-side resistance dT 20°	mbar	3.0	4.0	5.0	6.0	6.0
Ø - connection for air-independent operation	mm	75				
Electric supply		230V AC, 50 Hz, 13 A				
Power consumption at nominal power	W	29	29	30	31	32
Noise emission (operation) <sup>a</sup>	dBA	43.5				
<b>Hydraulics module (optional)</b>						
Designation		<b>Extension IHM 1</b> (Accumulator/HC)	<b>Extension IHM 2</b> (HC)	<b>IV</b> (Integrated piping)		
Flow connection height (FL)		1585 / 1570 mm	1570 mm	775 mm		
Return connection height (RL)		1530 / 1520 mm	1520 mm	1270 mm		
FL / RL connection		5/4 IT / 1 IT inches	1 IT inches	Outside-Ø 22 mm (Cu)		

- a. Emission of airborne noise from the pellet boiler in the boiler room; no significance attached to acoustic emissions at the chimney mouth or in the surrounding area

### 3.3 Flue pipe connection at rear or side

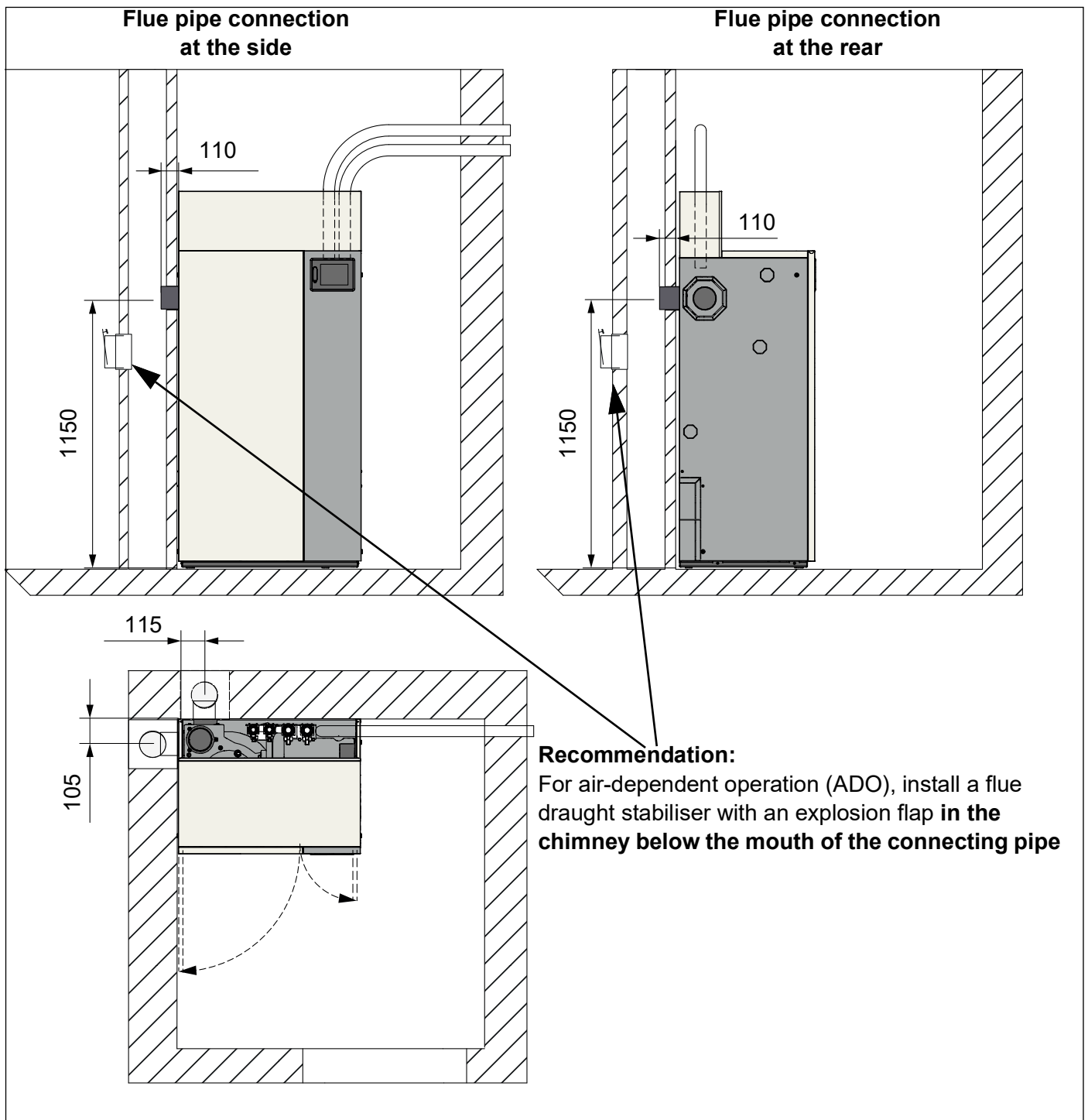

### 3.4 Flue connection set AIO Ø 100 mm (item no.: 7110917)

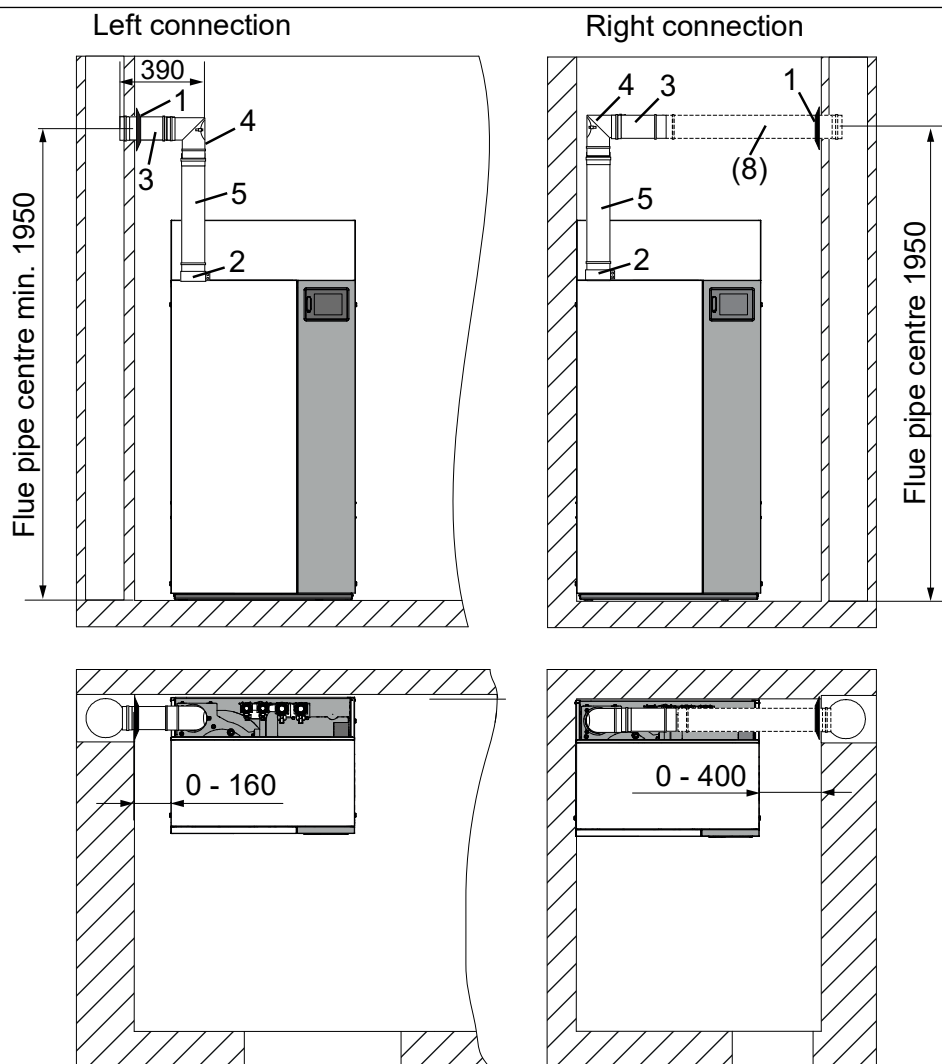

Preferred installation variant for right connection:  
 Use flue pipe connection at the rear  
 Height of flue pipe middle at least 1150 mm  
 ☞ Hydraulic lines pointing upwards do not have to be stepped down  
 ☞ System cannot be placed flush with the rear wall

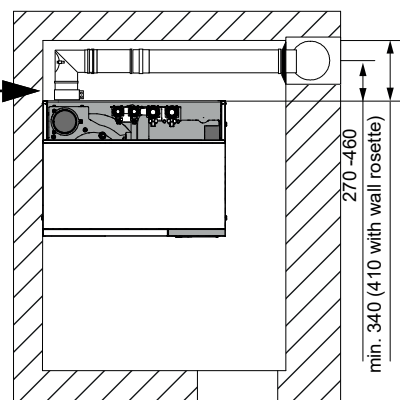

Set consists of the following components:

- Wall rose (1)
- Boiler clamp (2)
- 1 pipe element 190 mm (3)
- Elbow (4)
- 1 pipe element 440 mm (5)

For flue pipe to the right side, additional equipment is needed (example)

- 1 pipe element 940 mm (8) (shorten)

### 3.5 Flue connection set ADO Ø 100 mm (item no.: 7110916)

If no flue draught stabiliser can be installed in the chimney by the customer, installing a flue connection set with a flue draught stabiliser is recommended.

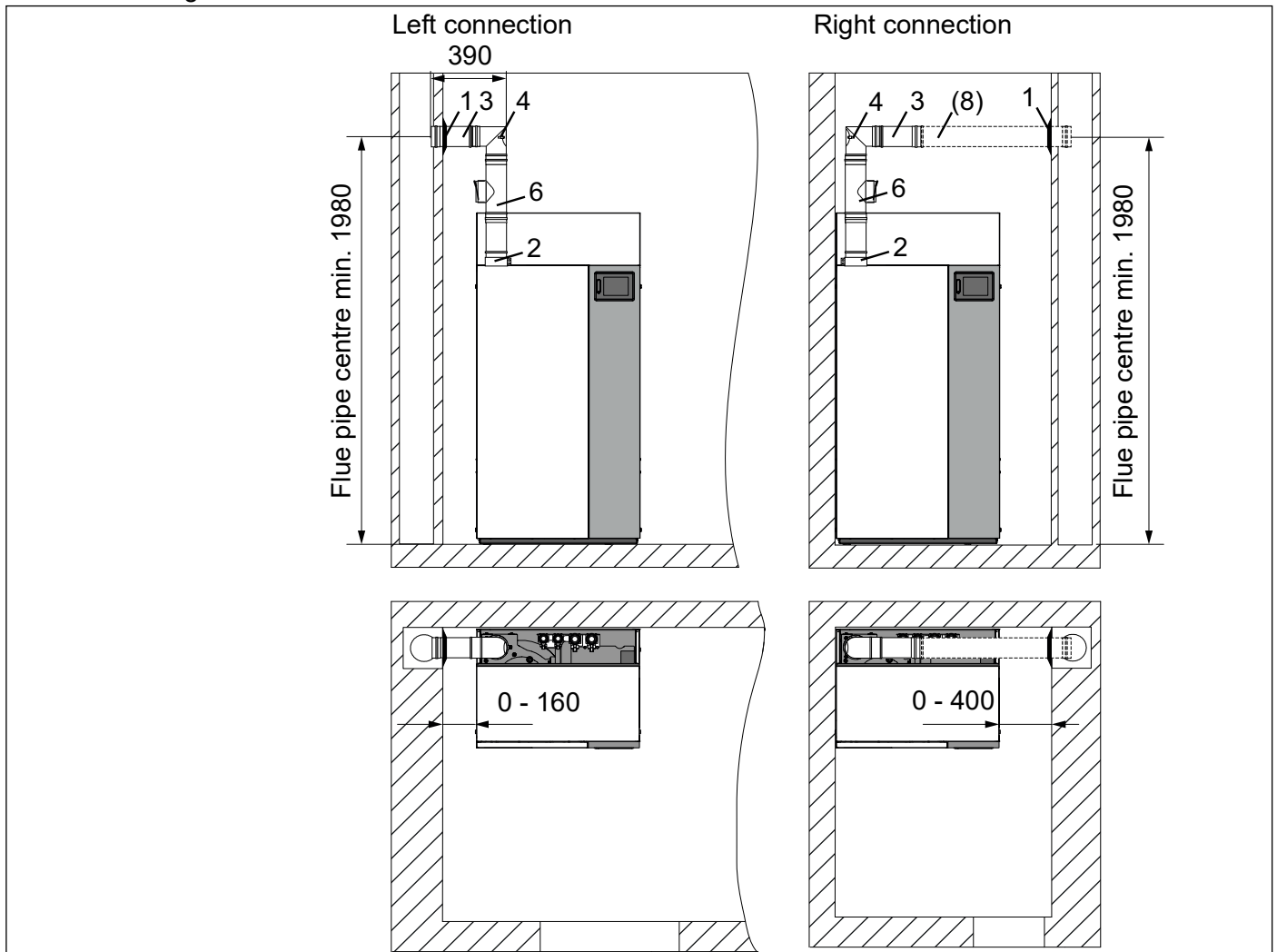

Set consists of the following components:

- Wall rose (1)
- Boiler clamp (2)
- 2 pipe elements 190 mm (3)
- Elbow (4)
- T-piece (incl. flue draught stabiliser) (6)

For flue pipe to the right side, additional equipment is needed (example)

- 1 pipe element 940 mm (8) (shorten)

Installation variant for right connection (no set):

Required individual parts: Wall rosette, T-piece, flue draught stabiliser, pipe element, elbow, boiler clamp

Use flue pipe connection at the rear

Height of flue pipe middle at least 1150 mm

- ☞ Hydraulic lines pointing upwards do not have to be stepped down
- ☞ The flue draught stabiliser must point forward and be visible from the front
- ☞ System cannot be placed flush with the rear wall

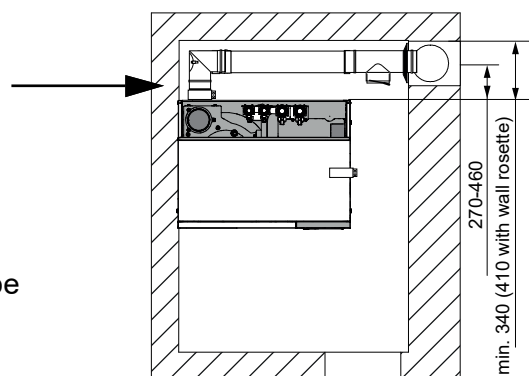

### 3.6 Flue connection set AIO Ø 130 mm (item no.: 7113917)

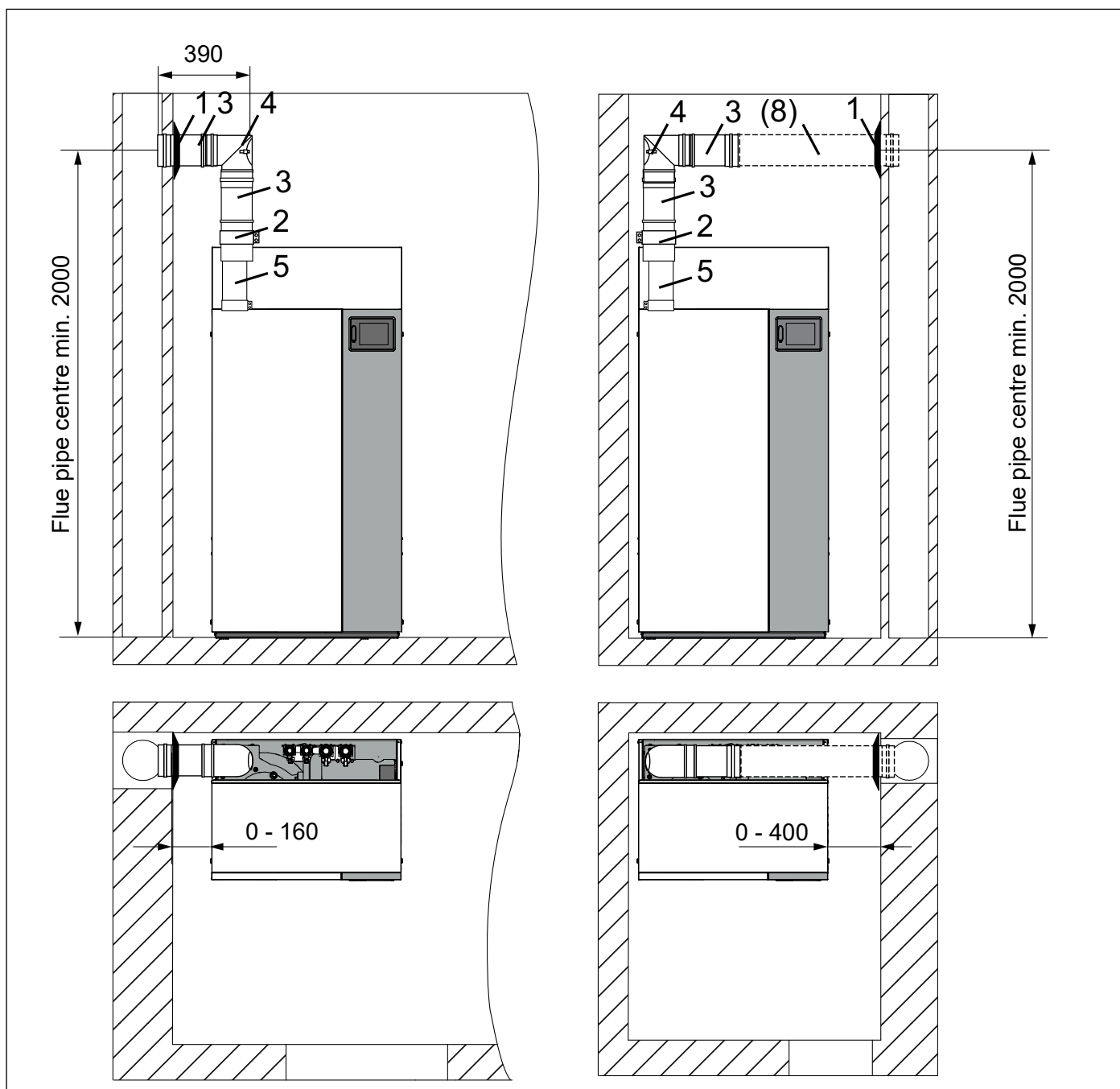

Set consists of the following components:

- Wall rose (1)
- Boiler clamp (2)
- 2 pipe elements 190 mm (3)
- Elbow (4)

Also required:

- Boiler clamp Ø 100 mm
- Adapter Ø 100 to Ø 130 mm (5)

For flue pipe to the right side, additional equipment is needed (example)

- 1 pipe element 940 mm (8) (shorten)

### 3.7 Flue connection set ADO Ø 130 mm (item no.: 7113916)

If no flue draught stabiliser can be installed in the chimney by the customer, installing a flue connection set with a flue draught stabiliser is recommended.

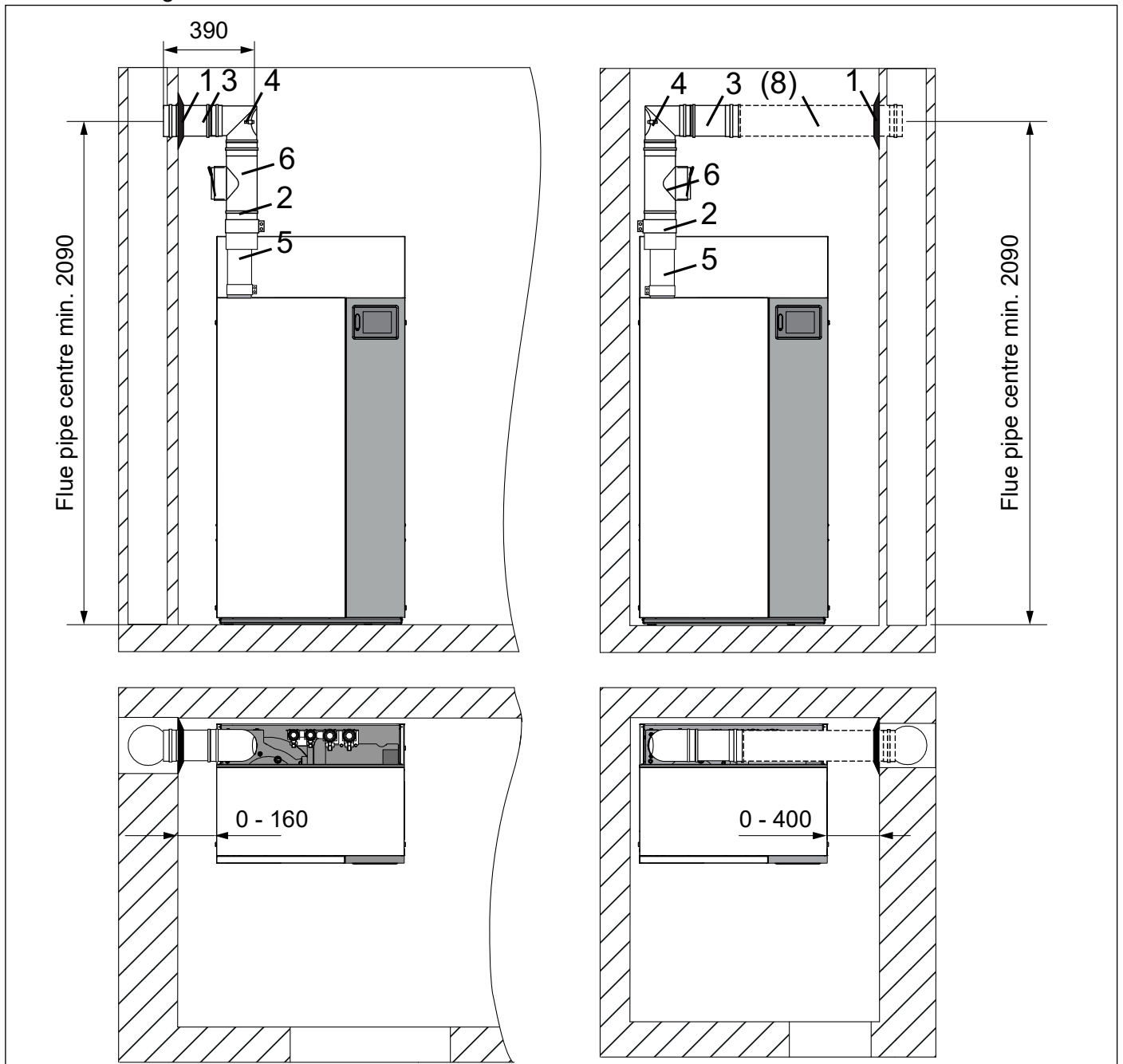

Set consists of the following components:

- Wall rose (1)
- Boiler clamp (2)
- Pipe element 190 mm (3)
- Elbow (4)
- T-piece incl. flue draught stabiliser (6)

Also required:

- Boiler clamp Ø 100 mm
- Adapter Ø 100 to Ø 130 mm (5)

For flue pipe to the right side, additional equipment is needed (example)

- 1 pipe element 940 mm (8) (shorten)

## 4 Scope of delivery overview

The system is delivered with a pre-assembled basic module.  
The optional extension/IV, if ordered, must be installed on site.

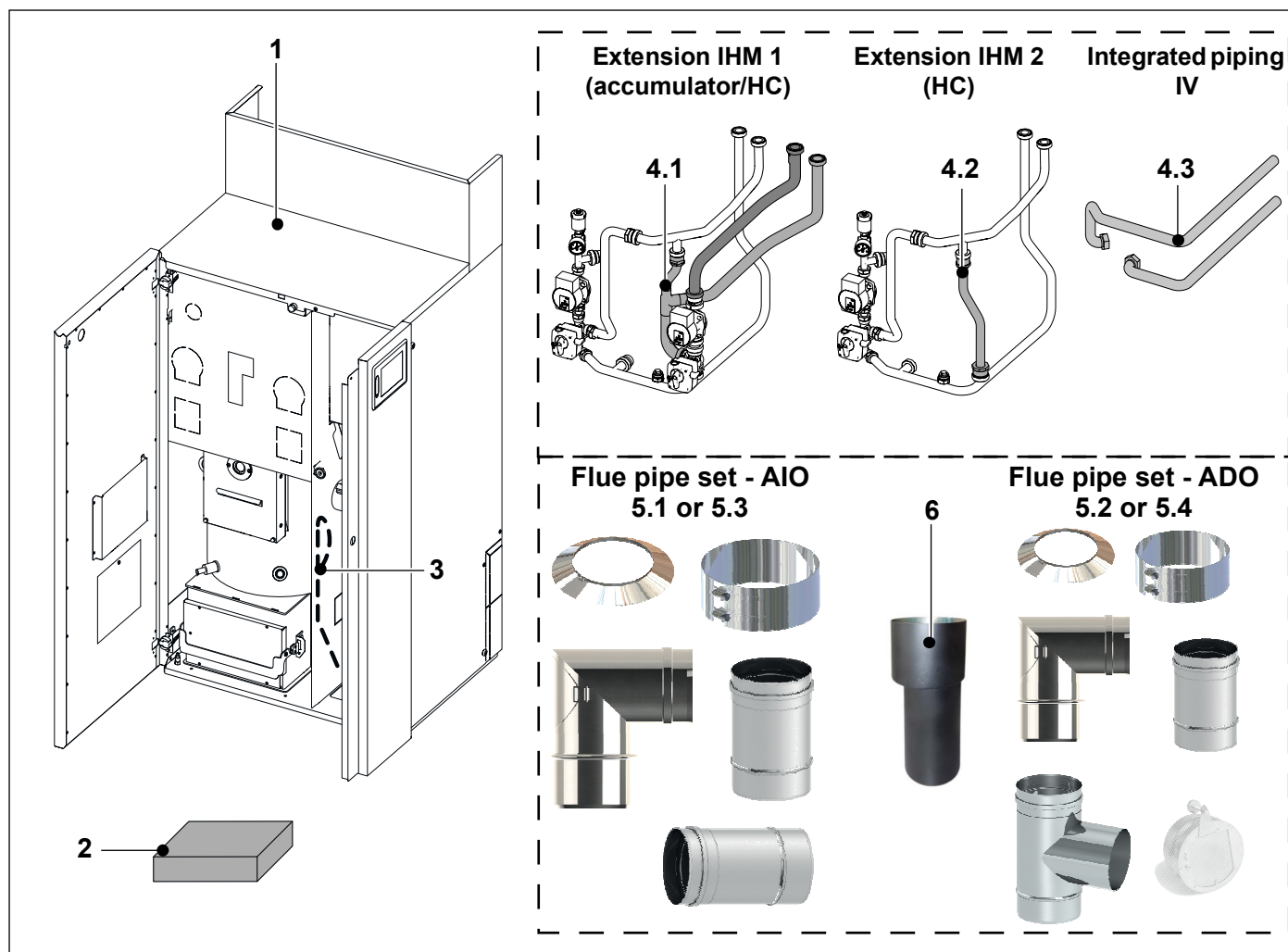

Item	Description	Function
1	Boiler	Pre-assembled boiler
2	Sensor package	Additional sensors (outside sensors, heat circuit sensors, etc.) according to sensor plan
3	Poker	For cleaning the combustion chamber
<b>Optional</b>		
4.1	<b>Hydraulic module:</b> Extension IHM 1	Accumulator/hot water tank and a heat circuit
4.2	Extension IHM 2	Heat circuit/boiler circulation
4.3	IV	Integrated piping in the boiler for on-site hydraulics
5.1	<b>Flue pipe set:</b> AIO - Ø 100 mm	Flue pipe set for chimney connection
5.2	ADO - Ø 100 mm	Connection: Ø 100 mm or Ø 130 mm
5.3	AIO - Ø 130 mm	Operating mode: Air-independent operation (AIO) or air-dependent operation (ADO)
5.4	ADO - Ø 130 mm	
6	<b>Flue pipe adapter Ø 100/130</b>	Adapter for Ø 130 mm chimney connection

## 5 Unloading the system

### DANGER



#### Danger to life and risk of material damage

##### Risk of death, injuries, damage due to falling or toppling loads

- The system may only be set up by qualified and trained staff.
- Only use tested lifting gear that has a sufficient load-bearing capacity and is in perfect condition.
- Do not exceed the maximum permissible load (load-bearing capacity) of the crane, forklift or lift truck. See the type plate.
- Never use bearing bolts, spindles, shaft ends or moving parts as attachment points to hoist the system or system parts.
- Make sure that nobody stands under suspended loads.
- First lift the system only minimally from the ground and only after the load has been completely picked up can the system be transported over longer distances.
- Check that the load attachment points are chosen correctly and are secure. Secure against tipping.
- Suspend the machine centrally to prevent the machine from tipping to one side.
- Arrange the ropes so that no components are damaged when the machine is lifted and the ropes do not slip.
- Avoid shocks and vibrations.
- Set up the system on a horizontal, even surface.

##### Transport with a fork lift

- Adjust the forks to the maximum distance and secure.
- Slowly lift the machine and transport it horizontally.
- Avoid shocks and vibrations.

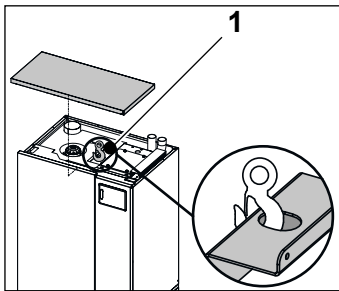

- If the system is unloaded using a crane, remove the cardboard
  - ☞ Do not damage the cardboard because it is needed as transport protection
- Remove the cardboard upwards
- Remove the cover lid from the system
- Attach the hoist (hook) to the transport lug (1)
  - ☞ Be aware of the risk of tipping during lifting
  - ☞ The load pick-up point is not above the centre of gravity

### 5.1 Disassembling the upper maintenance lid

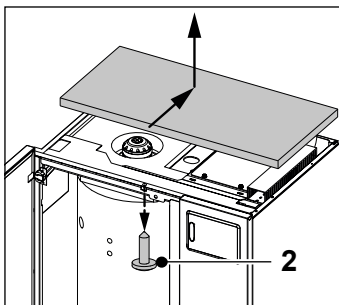

- Open left cover door
- Loosen screw (2) from maintenance cover
- Push the lid slightly backwards and lift upwards

## 6 Setup

There are several ways to transport the system to the boiler room

	<b>NOTE</b>
	For safe transport during installation, do not remove the pallet and cardboard from the system.

☞ Recommendation: Use at least four people to move the system into position

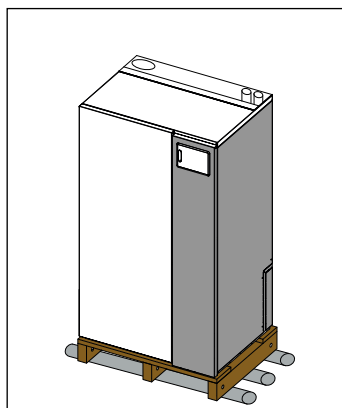

### Transporting the system on rollers

☞ For better rolling, use at least 1" pipes or equivalent

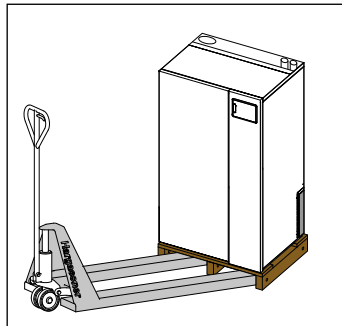

### Transporting the system with a lift truck or forklift

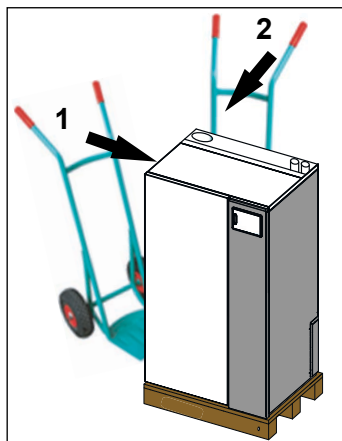

### Using a hand truck for positioning

☞ Use the hand truck to move the system into position to the marked position only:

- Narrow side of the system on the left **(1)**
  - Rear of the system on the right **(2)**
- Push the hand truck under the transport pallet
  - Secure the system with a suitable lashing strap
  - Position the system in the place provided for this purpose
  - Remove the transport timbers from the system

☞ If it is not possible to position the boiler due to structural conditions (spiral staircase, etc.) using the options mentioned above, the boiler can also be transported with carrying aids



### Positioning with carrying straps (stairway width < 1 m):

- At least four people
- Two carrying straps to be provided by the client
- Pass a carrying strap under the pallet on each narrow side
- Thread the ends of the strap to a pipe or similar

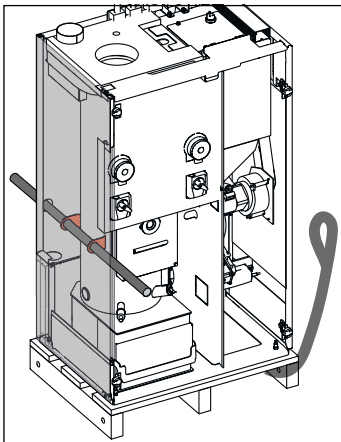

### Positioning with a carrying strap and pipe (stairway width > 1 m):

- At least four people
- One carrying strap and one 3/4" pipe to be provided by the client
- Remove cardboard
- Remove upper maintenance cover
- Dismantle cover doors
- Push the pipe through the carrying tabs on the boiler body
- Pull a carrying strap under the pallet on the day hopper side
- Thread the ends of the strap onto a pipe or similar

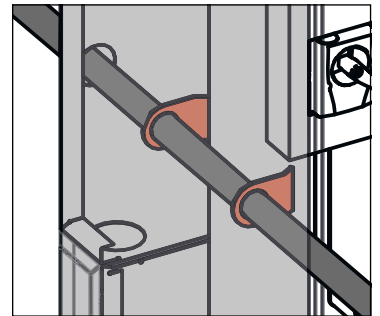

- ☞ If it is not possible to position the system due to structural conditions (spiral staircase, etc.) using the options mentioned above, the transport dimensions can be reduced

## 6.1 Reducing the transport dimensions

☞ Use at least two people to reduce the transport dimensions

### 6.1.1 Disassembling the cover

- Remove the cardboard and pallet after unloading the boiler
- Remove the cover doors
  - ⇒ See "Removing the cover door" on page 24.
- Remove the top maintenance lid
  - ⇒ See "Disassembling the upper maintenance lid" on page 15.
- Remove insulation

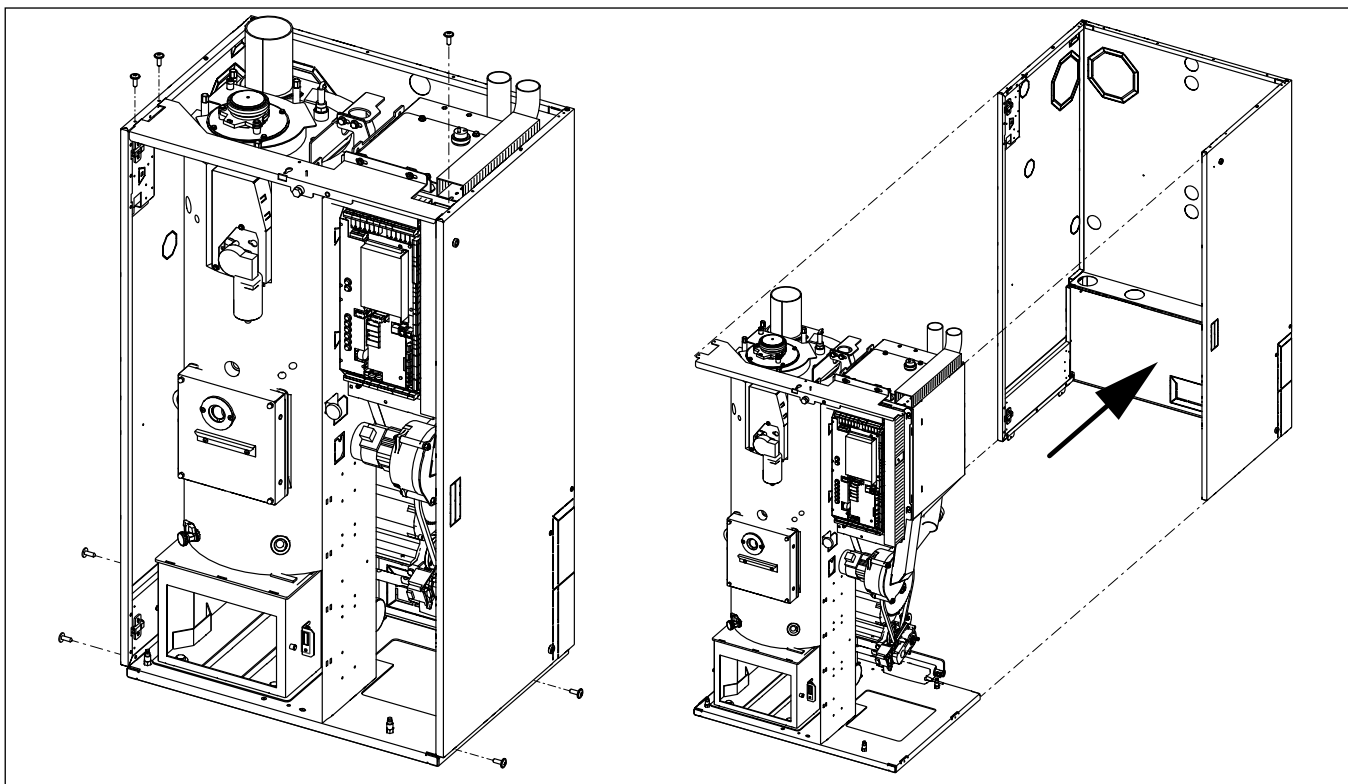

- Undo the screws in the casing
    - 2 on each side cover and 3 on the front connector
  - Remove the entire cover backwards
- Recommendation: Have at least two people remove the casing.

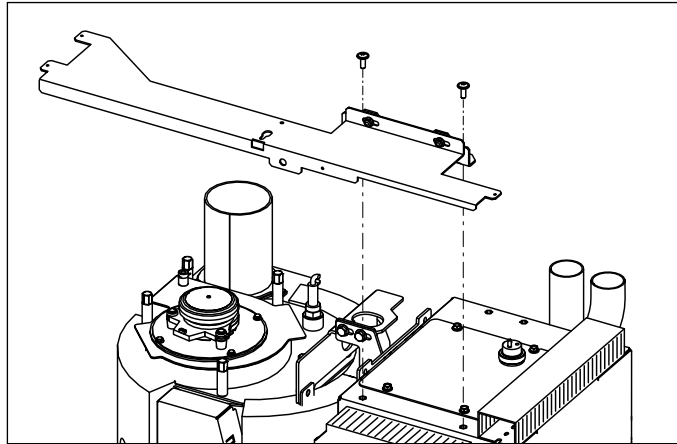

- Undo the screws in the front connector on the day hopper
- Remove the bracket with the front connector
- ☞ If it is still not possible to position the system after removing the cover, other parts of the system can be removed to reduce it to the smallest possible transport dimensions

### 6.1.2 Loosening and removing the wires

- Unplug the following from the main board (see electrical manual)
  - Safety temperature limiter STL (terminals 4/5)
  - Grate motor (terminals 18/19)
  - Boiler sensor (terminals 39/40)
  - Return sensor (terminals 35/36)
  - Ash box switch (terminals 32/33)
  - Mixer and pump extension IHM 1/2 (if present)
- Disconnect the plug connections
  - Exhaust fan
  - Lambda sensor
  - Cleaning motor
- Removing the sensors
  - Remove the flue gas sensor from the sensor sleeve

### 6.1.3 Disassembling the intermediate wall

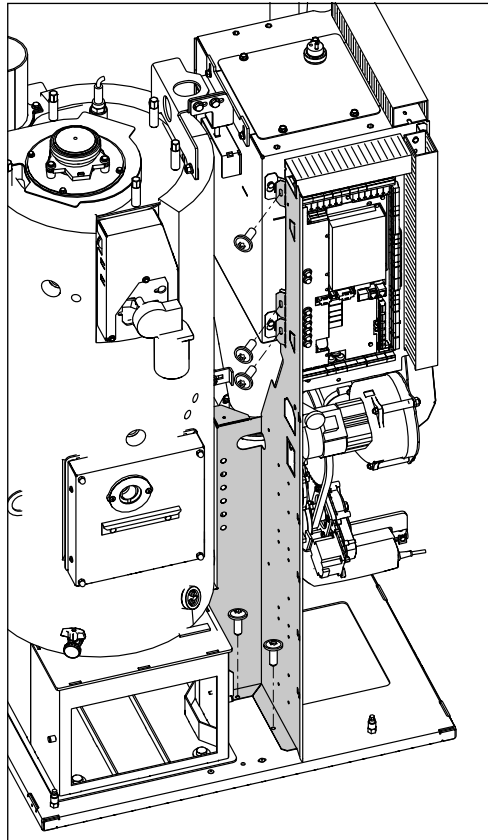

- Disconnect the ignition cable's plug connection
- Remove the hydraulics bracket
- Undo the screws in the intermediate wall
  - Loosen 3 on the day hopper and 2 on the base plate
- Remove the intermediate wall

### 6.1.4 Disassembling the stoker unit and the day hopper

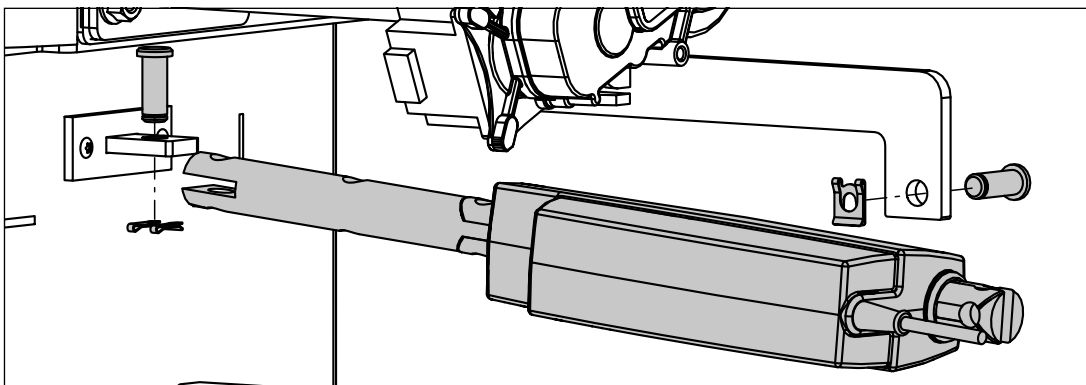

- Remove the spring clips and bolts at the front and rear of the grate motor
- Remove the grate motor to the rear

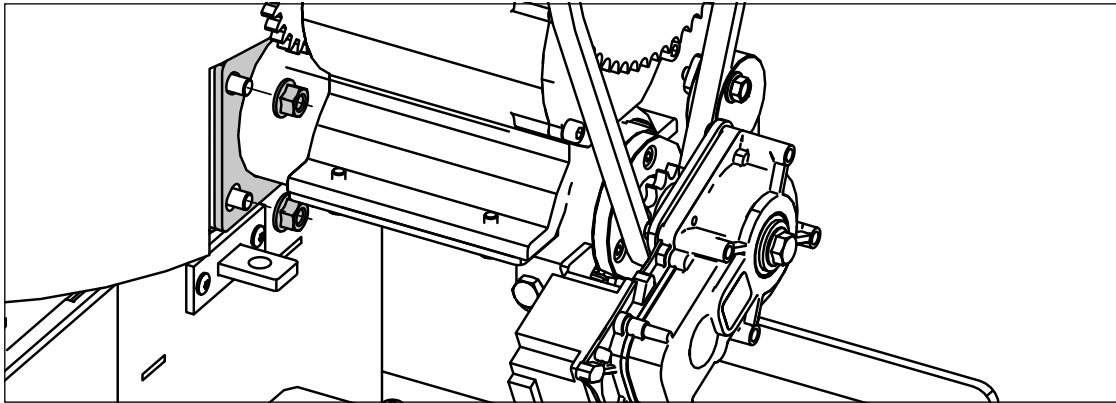

- ❑ Remove the screws and nuts in the stoker auger

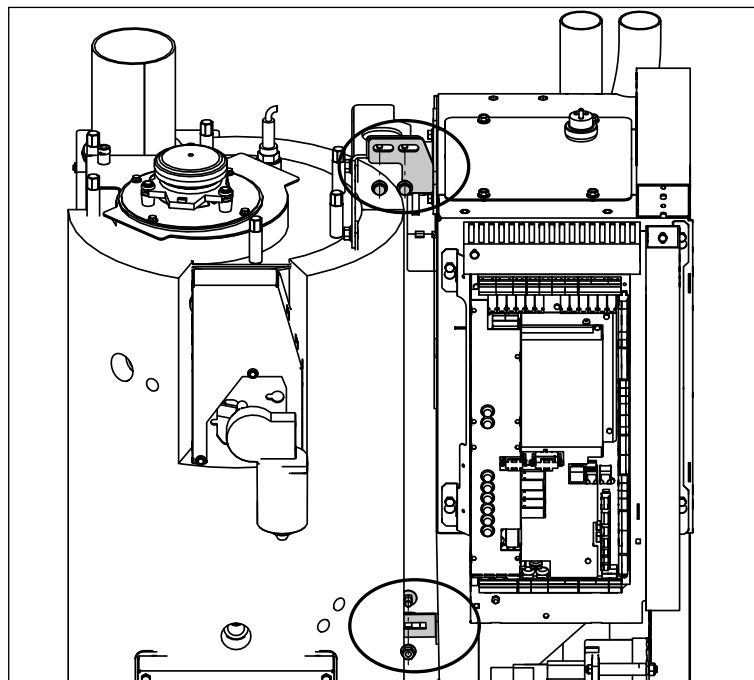

- ❑ Secure the day hopper against tipping
- ❑ Undo the day hopper's screw fittings at the top and bottom of the boiler body
  - ☞ Have a second person secure the day hopper and stoker unit

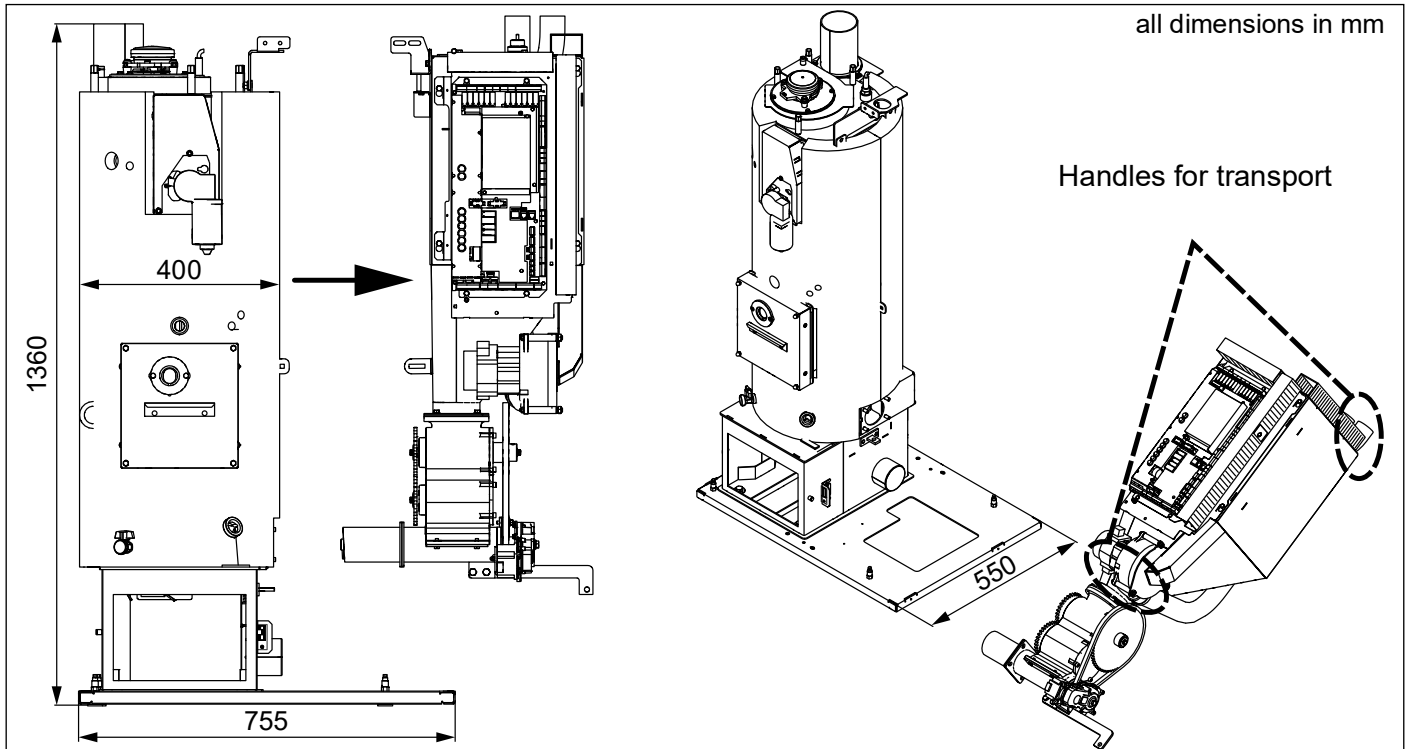

- Remove the day hopper and stoker unit by pulling them out from the right
- Carry the stoker unit to the installation location and rest it on the rear of the day hopper
- Loosen flow/return and remove basic module IHM
- Transport the boiler body to the installation location and reassemble it in reverse order

## 7 Fitting the levelling feet

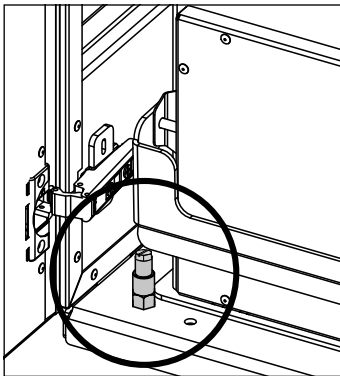

Once the system is in its final position, it needs to be levelled using the levelling feet.

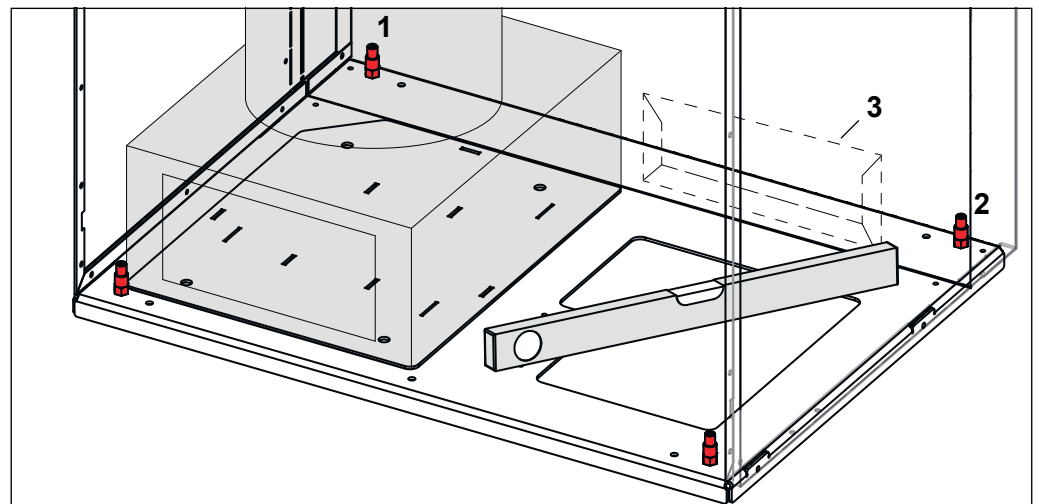

- Unscrew the left rear levelling foot **(1)** 1-2 cm
- Position the system against the wall
- For the right rear levelling foot **(2)**, break through and bend back the opening for air-independent operation **(3)**
- Adjust the two front levelling feet until the system is completely level
  - ☞ Hexagon wrench / slotted screwdriver

## 8 Adjusting the cover



### NOTE

Once these parts have been added, remove the transparent protective film from the coloured panels. The film is not heat-resistant.

- ☞ Recommendation: Adjust the cover first and then adjust the doors afterwards
- ☐ Remove the upper maintenance lid

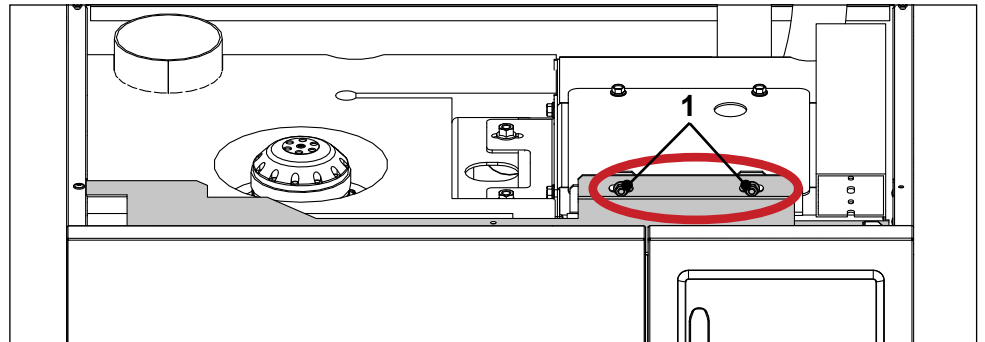

- ☐ Loosen both nuts (1) on the cover carrier

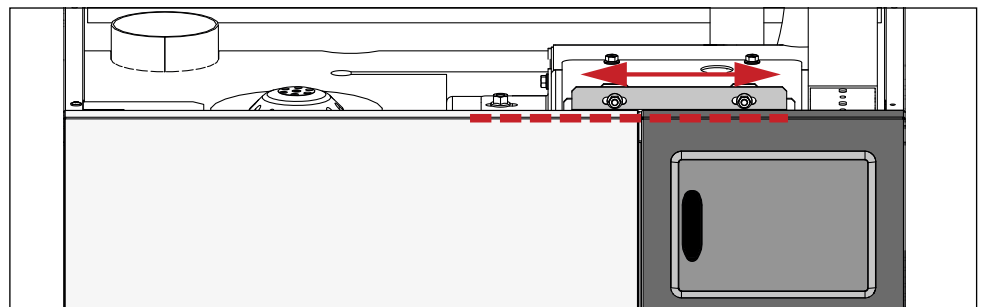

- ☐ Adjust the cover with closed doors
- ☐ Tighten both nuts on the cover carrier
- ☐ Re-fit the upper maintenance lid

### 8.1 Adjusting the cover door

Side adjustment +/- 2 mm	Height adjustment +/- 3 mm	Depth adjustment +/- 2 mm

---

## 8.2 Removing the cover door

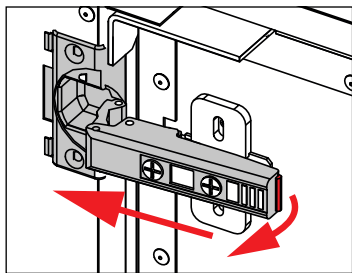

- Open and hold the door
- Loosen both hinges
  - Release the hinges at the rear
  - Remove the door from the mounting plate, pulling it forwards

## 9 Mounting instructions for pellet hoses and pellet steel pipes



### ATTENTION

#### Damage to the system due to incorrect laying of the pellet hoses

- Do not kink hoses.
- Hose temperature resistance: Minimum  $-5^{\circ}\text{C}$ , maximum  $60^{\circ}\text{C}$ .
- Do not allow the hoses to touch non-insulated heating pipes.
- Minimum distance to non-insulated flue gas pipes: 20 cm.
- Do not install hoses outside in an unprotected condition. Hoses are not UV-resistant.
- Observe the direction arrows of the return air hose and pellet suction hose.
- Ensure correct hose routing to overcome different height levels.
- Only use a single-piece pellet suction hose.
- Lay the hoses so that they are easily accessible for replacement in the event of wear.

### 9.1 Earthing the pellet hoses



### WARNING

#### Fire hazard

#### Fire due to electro-static discharge

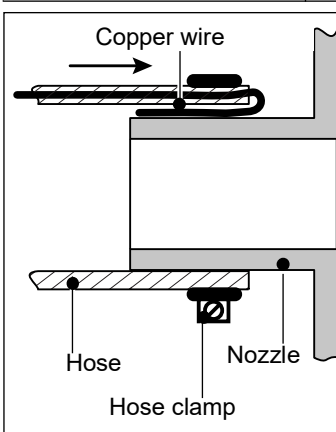

- Earth the pellet hoses at both ends with the copper wire inside the hoses.
- When extending the return air hose, use nozzles made of metal.
- Only connect earthing to bare surfaces.



Pellet transport in the hoses causes electrostatic charge.

- Earth the pellet suction hose and return air hose at each fixation to the nozzle (on both ends)
- Pull the copper wire out of the hose and strip approx. 5 cm of the insulation
- Clamp the copper wire between the nozzle and hose
- Insert the hose over the nozzle
- Secure the hose to the nozzle using the hose clamp

## 9.2 Marking the pellet hoses

	<b>A T T E N T I O N</b>
	<p><b>Material damage</b></p> <p><b>Damage to the system due to incorrect connection of the pellet hoses</b></p> <ul style="list-style-type: none"><li>• Connect the pellet hoses according to the direction arrows on the hose nozzle.</li></ul>
	<b>N O T E</b>
	<p>Label the pellet suction hose and return air hose permanently on their respective ends so that they cannot be mixed up.</p> <p>This prevents confusion during assembly or maintenance work.</p>

### 9.2.1 Point extraction RAPS

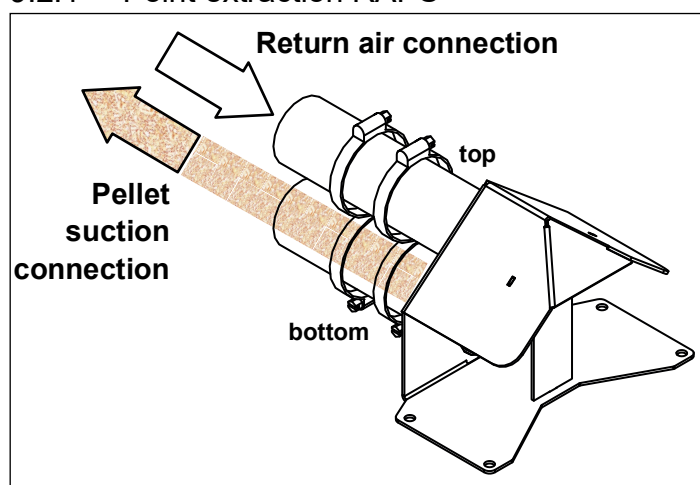

### 9.2.2 Fuel extraction auger RAS

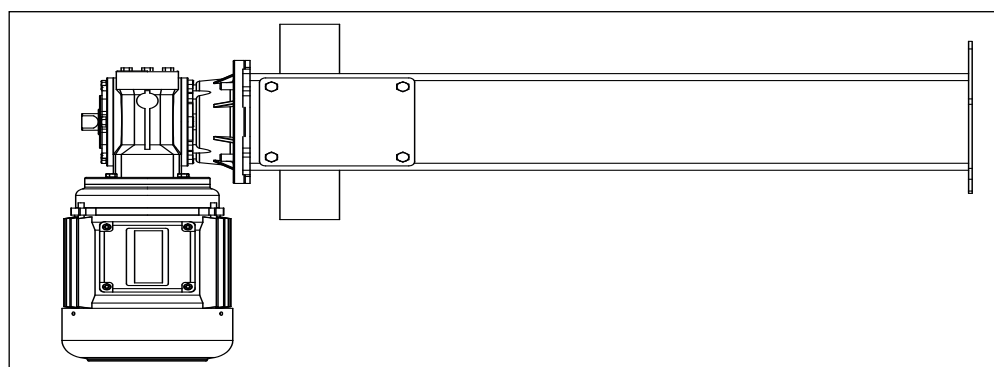

- Connect the pellet hose either on the left or the right nozzle depending on the available space

### 9.2.3 Bag silo GWTS / GWT-MAX

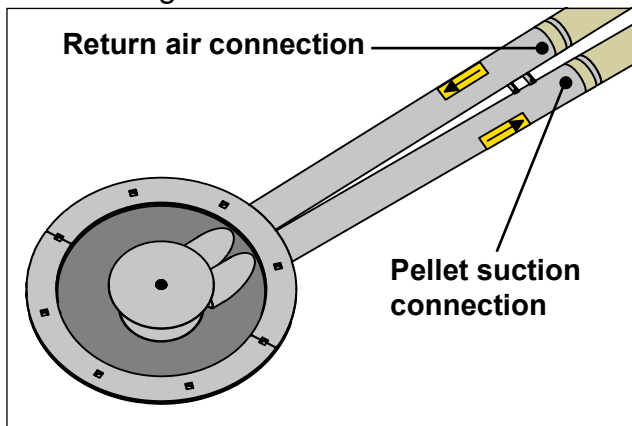

### 9.2.4 Pellets weekly tank PWB and underground pellet tank

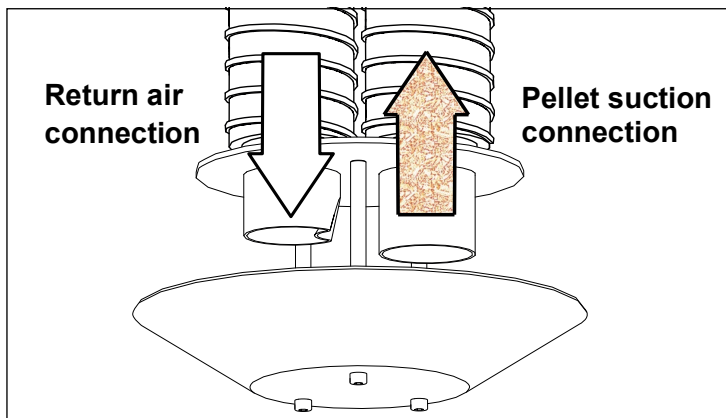

### 9.2.5 Changeover unit AUP

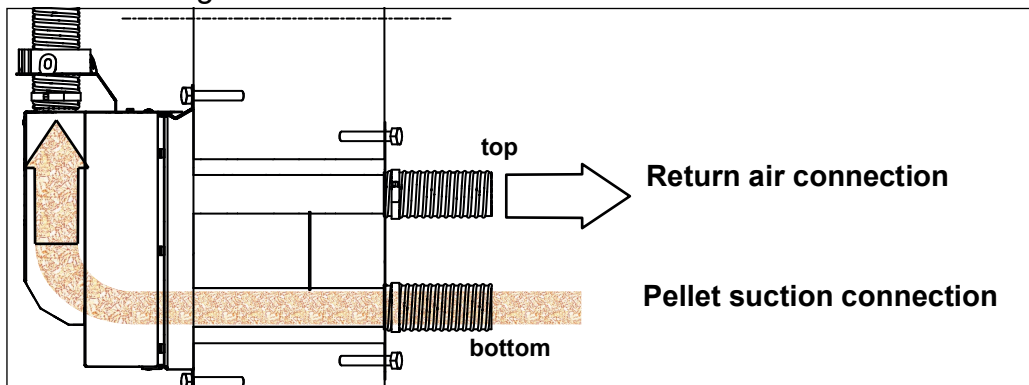

### 9.2.6 Pellet container on the system

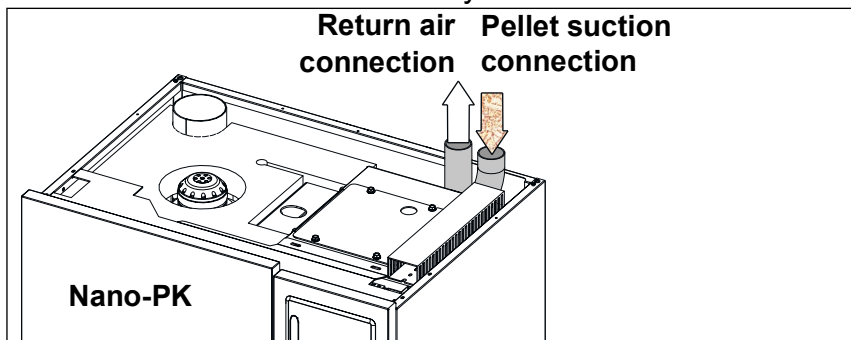

## 9.3 Laying pellet hoses

### 9.3.1 Laying the pellet suction hose

#### ATTENTION



#### Material damage

#### Blockage and abrasion by pellets during suction

- Make sure the laying radius is at least 30 cm over the entire length of the hose (check the radius with the enclosed gauge) or change direction with 90° steel pipe bends.
- Secure hoses against shifting using pipe clamps.

#### Pellet boilers below 70 kW

- Make sure the laying radius is at least 30 cm
  - ☞ The larger the radius, the better the pellet transport is
- Or change direction with 90° steel pipe bends

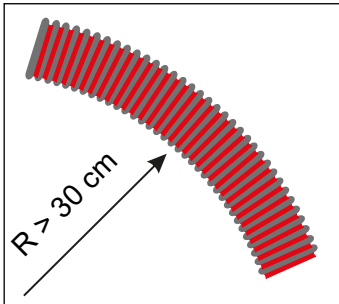

### 9.3.2 Laying the return air hose

- Make sure the laying radius is at least 30 cm
  - ☞ Use the enclosed gauge to check this

### 9.3.3 Pellet hose laying diagram/overcoming the height difference

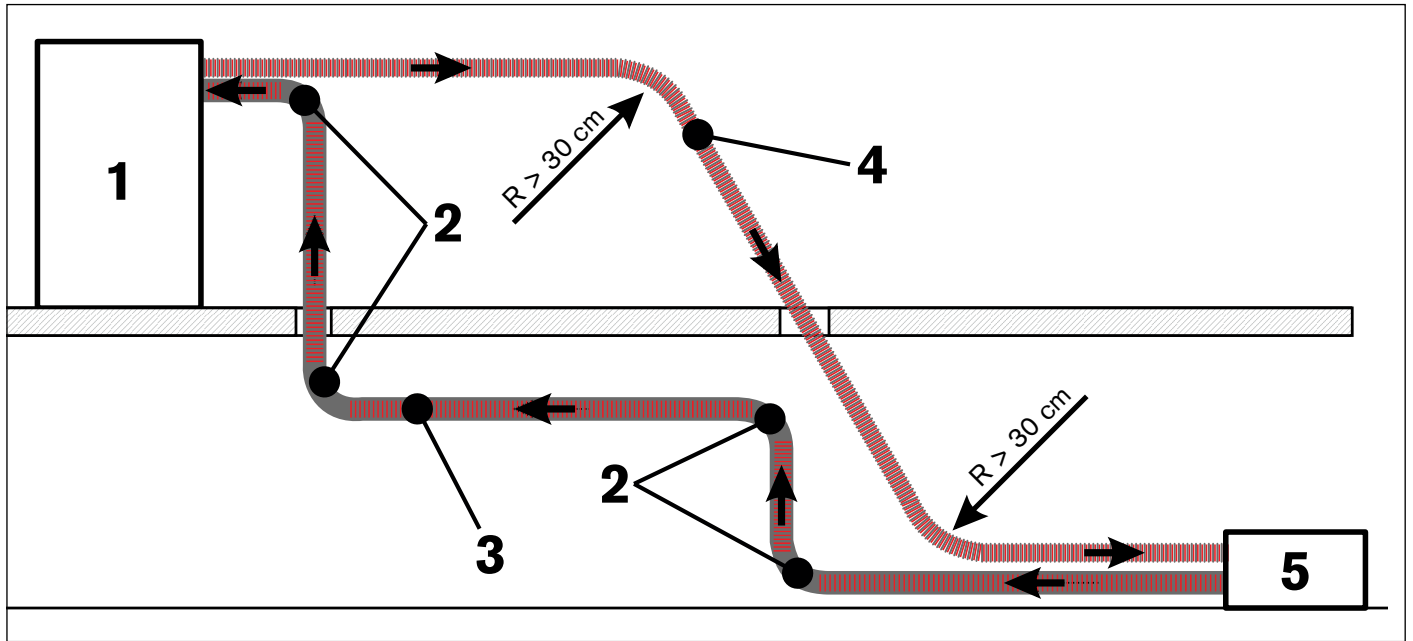

Item	Description
1	Hargassner pellet system
2	R > 30 cm or 90° steel pipe bends
3	Pellet suction hose
4	Return air hose
5	Pellet FE GWT, RAS, RAPS ...

- ☞ The suction turbine is designed to suction the pellets over a length of 20 m with pellet hoses and a height difference of 5 m
- ☞ A maximum of six 90° steel pipe bends can be used for a suction distance of 20 m
- ☞ When using a fuel extraction system RAS, the suction line can be up to 30 m long if the transport auger is cycled in the service settings. For longer or higher transport routes, always contact Hargassner Ges mbH
- ☞ When using point suction systems (RAPS, GWT), the pellets fall back down into the suction hose when the suction turbine stops. These pellets that fall back can block the pellet hose. To avoid this, install horizontal sections to overcome the height difference
- ☞ Use mounting clamps or support shells for better routing of the pellet hoses  
⇒ See "Wall fixing elements" on page 30.

### 9.3.4 Do not loop the pellet suction hoses

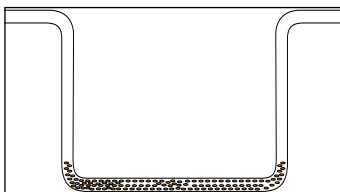

- ☐ Do not form loops (bags) in the hoses during laying
  - ☞ Pellets that fall back can block the suction hose

## 9.4 Accessories for pellet hoses and pellet steel pipes

### 9.4.1 Extension of the pellet hoses

#### ATTENTION



#### Material damage

#### Damage to the system due to incorrect extension of the pellet hoses

- Do not extend the pellet suction hose. Insufficient pellet transport.
- If necessary, extend the return air hose correctly.
- Connect the return air hose segments outside the pellet storage room to provide easy access to their point of assembly.
- Use a metal extension pipe.
- Connect the return air hose earth wire to the extension tube.

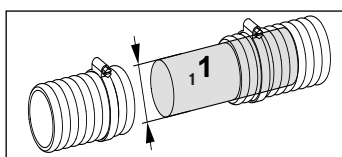

- To extend the return air hose, insert both hose ends onto a metal tube (1), earth them and secure them with hose clamps

### 9.4.2 Wall fixing elements

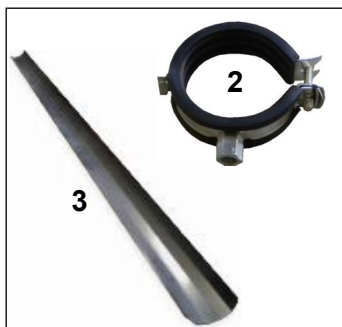

- Mounting clamps (2) and support shells (3) can be used to easily install the pellet hoses on the wall

### 9.4.3 Suction hose bend 90°



- Use the 90° suction hose bend with screw clamps for very tight curves or outward bends
  - ☞ Always use 90° steel pipe bends to change direction for pellet suction hoses from a 70 kW system output

### 9.4.4 Fire protection sleeve for pellet hoses



- Mount a fire protection sleeve on each pellet hose for each wall breakthrough

## 10 Design of the fuel storage room

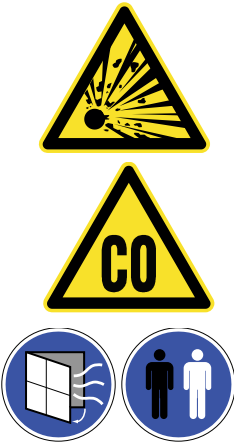
<b>D A N G E R</b>	
	<p><b>Risk of explosion, risk of suffocation</b></p> <p><b>Burns due to explosive burning of dust (pellet dust) in the storage room</b></p> <ul style="list-style-type: none"><li>• Ensure that the pellet hoses are earthed.</li><li>• No motors in the storage room.</li><li>• No other ignition sources (light) in the storage room.</li><li>• No electrical equipment (switches) in the storage room.</li><li>• No welding works in a dusty environment.</li></ul> <p><b>Risk of suffocation from odourless carbon monoxide</b></p> <ul style="list-style-type: none"><li>• Ventilate sufficiently before entering the storage room.</li><li>• Keep window and door open while inside.</li><li>• Position second person outside to supervise.</li></ul>

Design your fuel storage room in accordance with local regulations (e.g. EN ISO 20023 or VDI 3464).

- No electrical devices in the storage room; all lines to be installed concealed
- A separate fuel storage room is required for fuel quantities  $> 15 \text{ m}^3$ ; see the regulations specific to your country, e.g. TRVB 118 H
- Only install filling sockets and anti-rotation protection that are made from metal and earthed using a bonding conductor
- Consider noise protection for wall openings
- Protection against moisture, water and dust
- Correctly position impact protection mat and install slant floor
- Ventilation of the storage room according to legal requirements

### 10.1 Pellet storage room ventilation

☞ Storage rooms and storage containers must be ventilated to prevent a dangerous CO concentration

**General ventilation functions:**

- Ensure the exchange of air between the storage room and ambient air
- Install ventilation lines as short as possible and with as few changes of direction as necessary
  - ☞ Lowest possible pressure loss
- Preferably lead ventilation into the open air
  - ☞ Prevent rainwater entering through ventilation openings
- Design ventilation cross-sections according to local legal requirements
  - ☞ Various cross-sections depending on the size and design of the storage room

## 10.2 Safety in the fuel storage room





Observe the instructions on the fuel storage room sticker.

# FUEL STORAGE ROOM



## Pellet storage safety

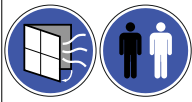

**DANGER**

	<p>Unauthorized persons are not allowed to enter the fuel storage room. Keep children away! Before entering: Switch off the system with the mains switch on the control unit!</p>
	<p>Odorless carbon monoxide can be produced in dangerous concentrations in pellet storage rooms.</p>
	<p>Ventilate the pellet storage room for at least 15 minutes before entering. Carry a CO warning device when entering. Keep doors open whilst in the room and force ventilate the storage room (e.g. with a fan or vacuum cleaner). Always have a second person outside the storage room to supervise!</p>
	<p>Prevent access to the transport auger and other moving parts!</p>
	<p>Do not use an open fire and do not smoke in the area of the fuel storage room!</p>

**WARNING**

	<p>Make sure you switch off the system before blowing pellets into the storage room! Danger of flue gas being sucked out of the boiler - risk of fire!</p>
	<p>Protect fuel against moisture!</p>

- Explain the contents of the sticker to the operator in detail
- Apply the sticker in the access area to the fuel storage room (storage room door, etc.), so that it is clearly visible and is read again before the storage room is filled
- Apply the sticker to a flat, well-adhering surface

# 11 Facilities on site

## 11.1 Country-specific regulations

	<b>NOTE</b>
	Observe country-specific regulations. The regulations and safety provisions for operating combustion systems and storing fuels vary from country to country.

Observe the following country-specific official regulations before commissioning:

- Fire protection
- Operating combustion systems
- Storage of fuels
- Designs of the boiler room and fuel storage room
- Requirements from chimney sweep

## 11.2 Qualification of installation staff

	<b>WARNING</b>
	<b>Risk of injury and/or material damage</b> <b>Risk of injuries and damage due to improper installation</b> <ul style="list-style-type: none"><li>• Work on the electrics, hydraulics, components of the flue gas system, structural measures and measures for fire protection must only be carried out by authorised staff.</li></ul>

In addition to the operation manual and the binding accident prevention regulations applicable in the country of use and at the place of use, the recognised technical rules for safe and professional work must also be observed.

## 11.3 Fire extinguisher



Install an inspected (every 2 years) fire extinguisher in an easily accessible place outside of the boiler room right next to the boiler room door.

Boiler room size	Amount of extinguishing powder	Certification
< 20 m <sup>2</sup>	6 kg	EN3
20 - 50 m <sup>2</sup>	12 kg	EN3

## 11.4 Designs of the installation space

- ☞ Design installation spaces in accordance with local regulations
- ☞ Ensure sufficient supply of combustion air
- ☞ Accessible for operation, inspection and maintenance
- ☞ Do not store any flammable materials near the system
- ☞ Do not use cleaning agents containing chlorine and hydrogen halides

## 11.5 Designs of the boiler room

- ☞ A boiler room is required for combustion systems with a nominal heating output of over 50 kW
- ☞ Design boiler rooms in accordance with local regulations
- ☞ Ensure fireproof, level and solid floor and ceiling construction
- ☞ Weatherproof and frost-proof (ambient temperatures of up to +40°C)
- ☞ Free of disturbing electrical installations and pipes
- ☞ Do not store any flammable materials near the system

### 11.5.1 Austrian regulations

- Country-specific boiler room regulation
- Ö-Norm M7510 (inspection of heating systems of solid fuels)
- TRVB 118 H (preventive fire protection)
- TRVB 124 F (first and extended extinguishing help)
- TRVB 105 H (fireplaces for solid fuels)
- TRVB C 141 (outdoor storage of solid, flammable fuels)
- Ö-Norm H5170 (heating systems - requirements for building and safety technology as well as fire and environmental protection)
  - Walls and ceilings REI 90 (F90)
  - Doors EI<sub>2</sub>30-C (F30)
  - Protect storage room against water ingress

### 11.5.2 German regulations

- FeuVO (fire regulation of federal states)

### 11.5.3 Swiss regulations

- A system room is required for combustion systems with a nominal heating output of over 70 kW
- VKF (Association for Cantonal Fire Insurance Companies) fire safety guidelines
- ☞ Important points from the VKF "Fire protection guidelines" - version 01.01.2017
  - Doors with EI 30 fire resistance and walls with EI 30 fire resistance
  - Walls behind combustion systems must be made of fire-resistant material and be at least 0.12 m thick

### 11.5.4 Fire resistance of the wall breakthrough

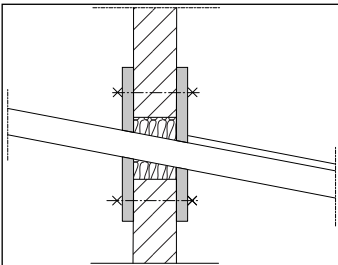

Ensure that the wall breakthrough complies with the EI 90 fire resistance class

- ☞ Applies if a fuel storage room is required
- Wall opening maximum 50 cm x 50 cm
- Cover with steel sheets (thickness of at least 1.5 mm)
- Cover with fire-resistant plates (thickness of at least 8 mm)
  - ☞ Use at least 10 screws for fixing the cover in place
- Ensure that there is a gap between the wall and the fuel extraction system
  - ☞ Prevents sound transmission
- Filling: fill with rock wool EI 90 (F90)

## 11.6 Ventilation of the boiler room (for systems without AIO)

Air openings must be installed in the boiler room for the firing.

	<b>NOTE</b>
	<p>Please refer to the local regulations for the size of the air openings.</p> <p>Minimum dimensions: Provide at least an air supply opening of 4 cm<sup>2</sup> per kW boiler nominal heating output, but at least a total cross-section of 400 cm<sup>2</sup>. It must be ensured that no impairment is caused by air currents or atmospheric influences. If there are cover grilles or similar installed, the cross-section area must be maintained.</p>

## 11.7 Air-independent operation (AIO)

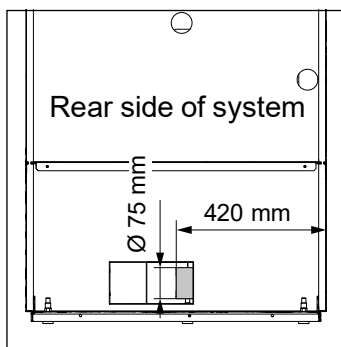

It is best to use an air-exhaust system (AES) for the air supply because the outlets of this AES are either concentric or so close to each other that they are affected by similar wind conditions.

If the air supply is provided through a chimney-independent line, a wind protection device has to be used.

If a protective grid is installed, ensure that the mesh size is sufficient to prevent pressure loss and/or blockage due to contamination.

If the air supply is routed through any other rooms, the pipe must be sheathed in materials that meet the requirements of fire resistance class EI90 (F90).

The supply pipe must be no more than 15 m long and can include up to four 90° bends. Each 90° bend decreases the maximum length of the supply pipe by 1 m. The maximum negative pressure in the power supply is 20 Pa.

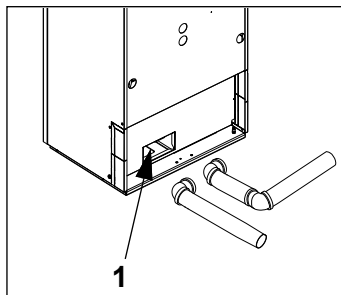

### Minimum requirements for the combustion air (fresh air) supply pipe in accordance with EN 1856-2

EN 1856-2: T080 - N2 - D

- T080 = Temperature resistance up to 80°C
- N2 = Tightness class 20 Pa
- D = Condensate resistance not required
- Install the air supply line as short as possible
  - ☞ Do not exceed 15 m
  - ☞ Maximum 4 bends of 90°
- The connection flange on the pellet boiler (**1**) is designed for a high-temperature pipe (HT) with a diameter of 75 mm
  - ☞ Never use an underground drainage pipe (KG) (temperature resistance)
  - ☞ Ensure a tight fit of seals (HT pipe)
  - ☞ Connection at the rear of the system can be made to the rear, left or right. Break the corresponding opening out of the cover
  - ☞ Connection: one 90° HT pipe bend and one HT socket pipe
- When using an air supply hose, protect it from mechanical damage
  - ☞ To prevent condensation, use insulation that complies with EnEV (only applies to Germany)

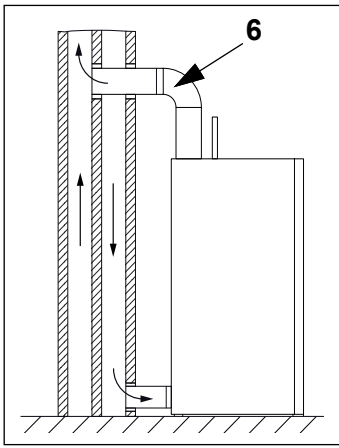

### Minimum requirements for the flue gas pipe according to EN 1856-2

- Operation without condensation heat exchanger: EN 1856-2 T400-N1-D-G
- Operation with condensation heat exchanger: EN 1856-2 T200-P1-W2-G
  - T200/T400 = Temperature resistance up to 200/400°C
  - P1 = Tightness class 200 Pa
  - N1 = Tightness class 40 Pa
  - D = Condensate resistance not required
  - W2 = Condensate resistance
  - G = Soot-fire resistance

- Glue the connecting element (6) at the transitions with aluminium adhesive tape (heat-resistant) and insulate as described in the operation manual
- Replace connecting pipes that have seals after a malfunction (soot fire)

### Chimney design

- EN 1856-2: T200 - P1/N1 - W2 - G

☞ **Do not install a flue draught stabiliser in the connecting element or the chimney**

	<b>ATTENTION</b>
	<p><b>Risk of suffocation</b></p> <p><b>Suffocation due to formation of dust and smoke due to system leakages</b></p> <ul style="list-style-type: none"> <li>• Observe safety instructions for air-independent operation.</li> <li>• Do not install a flue draught stabiliser.</li> <li>• Always fully close and lock the ash pan.</li> <li>• Replace connecting pipes that have seals after a malfunction (soot fire).</li> </ul>

## 11.8 Flue connection, flue pipe

Description	Unit	Nano-PK 6	Nano-PK9	Nano-PK10	Nano-PK12	Nano-PK15
Power	kW	1.8 - 6.6	2.7 - 9.0	3.2 - 10.5	3.6 - 12	4.5 - 15
Flue gas temperature	°C	130				
CO <sub>2</sub>	%	14				
Mass flow rate	kg/sec	0.0037	0.0050	0.0058	0.0066	0.0083
Necessary delivery pressure (available delivery pressure for systems in AIO operation)	Pa	2 (5)				
Flue draft max. limit	Pa	10				
Flue pipe diameter	mm	100				

The flue gas system must be designed in accordance with local regulations or ÖNORM EN 3384-1.

- The flue pipe is rising towards the flue and should be as short as possible
- Install appropriate openings for cleaning
- Insulate the flue pipe
  - ☞ Protection from hot surface on the flue pipe (risk of burns)
  - ☞ Protection from flammable parts and materials (e.g. electrical wiring)
  - ☞ For reducing condensation
  - ☞ Insulation (foil-laminated rock wool) 30 mm, optimum > 50 mm
  - ☞ Tape joints
- No flammable materials within 20 cm of an insulated flue pipe

### 11.8.1 Installing the flue pipe connection

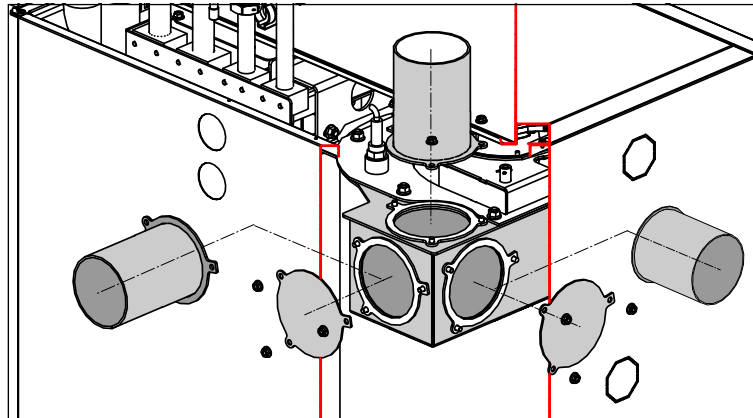

- ☞ Position the flue pipe connection according to the structural conditions on-site
  - Top (standard), side or rear

The following installation steps are necessary if the flue pipe connection is on the side or rear

- Break out the respective opening in the cover
- Undo the screws and nuts in the blind cover and remove the cover
- Disassemble the flue pipe connection at the top and mount it at the opening of the flue gas duct
- Close the upper opening with the blind cover

### 11.9 Flue draught stabiliser

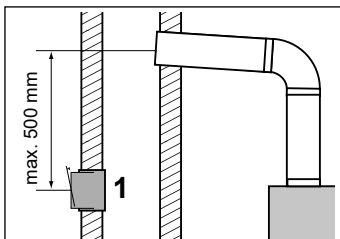

For air-dependent operation (ADO) system, a flue draught stabiliser with an explosion flap (1) must be installed in the chimney below the mouth of the connecting pipe.

- Set the flue draught stabiliser to 10 Pa using the gas meter
- Install the flue pipe rising towards the flue
- ☞ Maximum distance to the flue pipe junction in the flue 500 mm
- ☞ A flue draught stabiliser installed in the flue is beneficial in overpressure situations and when the flue draught is poor

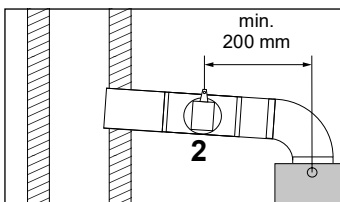

If installation in the flue is not possible, a flue draught stabiliser with an explosion protection flap (2) must be installed in the pipe connecting to the flue.

- ☞ Minimum distance to the flue gas sensor 200 mm

For flue draughts of < 30 Pa, the flue draught stabiliser can be shut off.

## 12 Hydraulic installations

- ❑ Install the hydraulics according to the enclosed hydraulic schematic
  - ☞ Design criteria according to EN 12828
  - ☞ A circulation pump is required for low-temperature systems (floor or wall heating systems) with mixers
  - ☞ Piping and seals must be able to withstand a maximum temperature of 110°C
  - ☞ Note the connection descriptions on the system
  - ☞ A domestic hot water mixer is mandatory for an accumulator tank with integrated domestic hot water coil
- ❑ Connect all safety devices
  - ☞ Thermal safety circuit
- ❑ Check the opening direction of the mixer
- ❑ Install the control valves according to the hydraulic schematic
- ❑ Install the sensors according to the hydraulic schematic
  - ☞ See "Sensor installation" on page 42.
- ❑ The chemical and physical properties of heating water must comply with country-specific standards (EN 12828, ÖNORM H 5195-1, VDI 2035, SWKI BT 102-01, SIA 384)
- ❑ The electrical conductivity of the heating water should be between 20 and 200  $\mu\text{S}$
- ❑ When filling the heating system with heating water, do not allow air to enter the heating system
  - ☞ Vent the filling hose before connecting it
- ❑ Only use approved heating filling devices for filling with heating water

### 12.1 Domestic hot water mixer

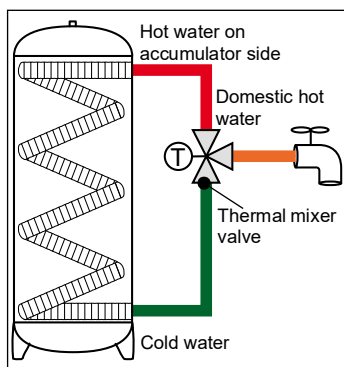

Hot water heating using an accumulator tank with an integrated domestic-hot-water coil, an integrated HWT or an external HWT.

- ☞ To protect against scalding, a thermal mixer valve must be installed

## 12.2 Internal hydraulic module extensions

### 12.2.1 Extension IHM 1 for accumulator/hot water tank and a heat circuit

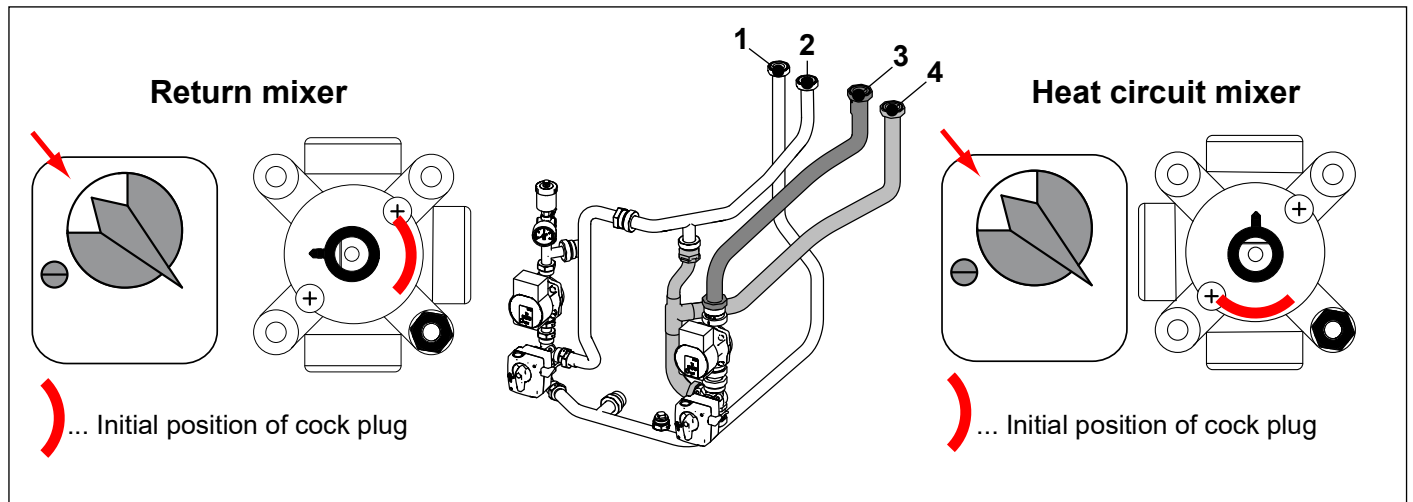

#### Extension IHM 1 connections

- Flow (1) and return (2) accumulator/hot water tank 1 inches internal thread
- Flow (3) and return (4) heat circuit 5/4 inches internal thread

### 12.2.2 Extension IHM 2 for heat circuit/boiler circulation

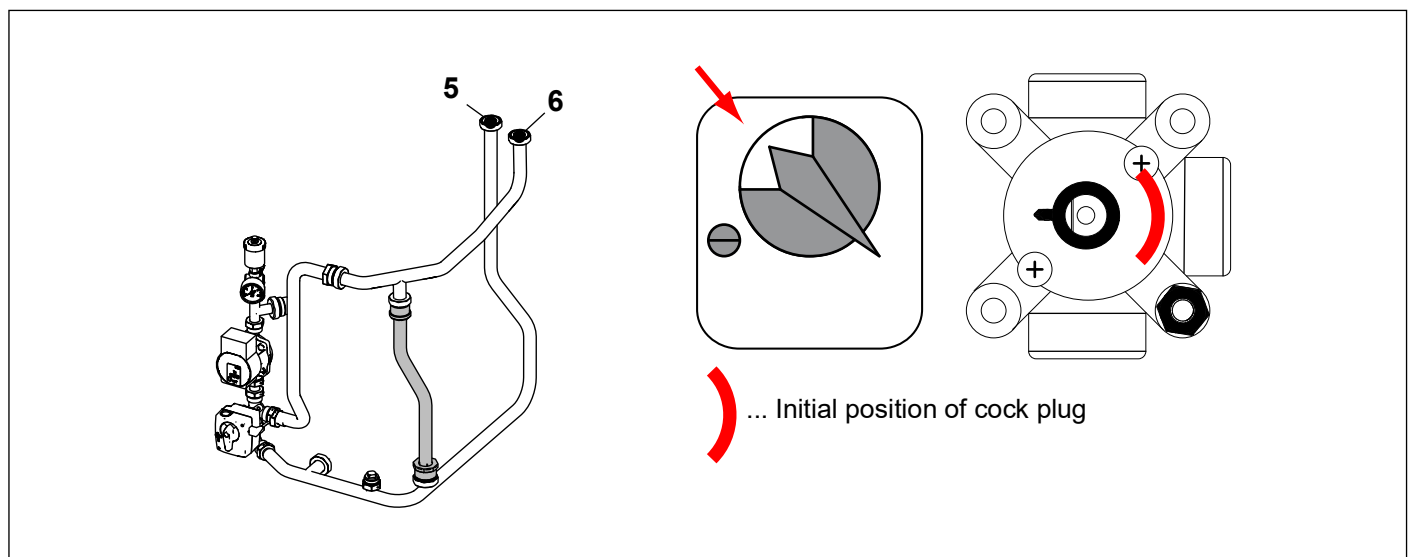

#### Extension IHM 2 connections

- Flow (5) und return (6) heat circuit 1 inch internal thread
- ☞ With the optional bypass line, no accumulator can be connected
- Caution:** The leak test must be performed by the commissioning engineer.

## 12.3 Safety group



- Install the safety group (9) in the return
- ☞ With a basic module IHM installed, the safety group is pre-assembled
- Check for leaks

### 12.3.1 Safety group drain

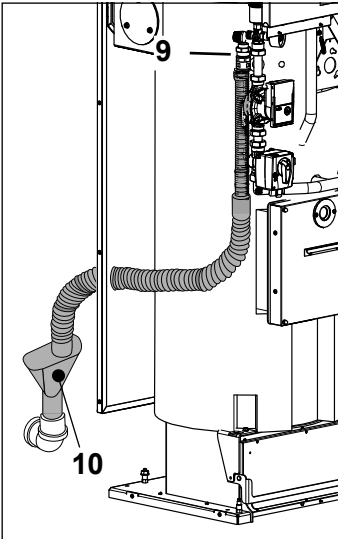

- ☞ Recommendation: When using an **extension IHM**, install a drain (10) as shown in the adjacent figure
- Install a drain with a drain funnel for the safety group
  - ☞ The drain funnel must be easy to inspect in order to detect a leak (drops) in the safety valve
  - ☞ Drain must be free-flowing: remove blockages immediately
  - ☞ Design the drain with a siphon
  - ☞ The drain can be at the back, at the bottom or at the side
- Install the expansion vessel in the return (accumulator/HWT) on site

## 13 Electrical installations

	<b>D A N G E R</b>
	<p><b>Danger to life</b></p> <p><b>Electric shock from contact with live terminals</b></p> <ul style="list-style-type: none"><li>• Observe information signs.</li><li>• Before starting work, check that no voltage is present using a voltmeter.</li></ul>

A detailed electrical manual is enclosed to help with the electrical installation.

- Wiring diagram
- Electrical diagram of the sensors, motors, pumps, mixers, proximity switches
- Information regarding connecting the main power switch in front of the boiler room door
- Instructions on extending the cables

### **Working on the system's electrical equipment**

- The electrical connection has to be executed according to the enclosed electrical manual through a licensed and authorised electrician
- Connect equipotential bonding conductor
- Suction hoses (if used) must be earthed (see sticker)

	<b>W A R N I N G</b>
	<p><b>Fire hazard</b></p> <p><b>Risk of injuries and damage from flammable material</b></p> <ul style="list-style-type: none"><li>• During the electrical installation process, be aware of the position of the flue pipe.</li><li>• The insulation of cables and cable shafts is flammable.</li><li>• The distance from electrical wires to the bare flue pipe must be at least 40 cm.</li></ul>

When laying the electrical cables outside the system (main connection, sensors, pumps, mixer control), make sure you observe the minimum distance to the hot flue pipe and exhaust fan.

- Power supply to the control unit
- Protection of the power supply with back-up fuse according to electrical diagram
  - ☞ Note the instructions in the wiring diagram
- Main heating switch (emergency stop) in front of the boiler room door
  - ☞ Install a horn or warning light so that it can be noticed easily and reliably
  - ☞ Complete disconnection of the electrical power supply to the control unit
- Connection of all necessary safety equipment
  - ☞ All sensors for safe operation of the system (according to wiring diagram)
- Connections of heat circuits (pumps, mixers, sensors)
- Install outside temperature sensor
  - ☞ Do not install in direct sunlight
- Connect the earthing terminal on the system to the protective earth conductor in the control cabinet

### 13.1 Cable installation

- ☐ Connect the cables and sensors according to the enclosed electrical manual

## 14 Sensor installation

### 14.1 Outdoor sensor



#### Position

- Coldest side of building away from the sun (North; North-East)
- Installation height min. 2 m
- On insulated external walls
- Check for external heat sources (falsification of measured values)
  - ☞ Flue, warm air from air ducts, windows and doors
- Cable outlet from sensor on bottom
  - ☞ Prevent moisture ingress
- Electrical installation with 2-pole cable
  - ☞ See the wiring diagram for the minimum cross section

### 14.2 Flow, accumulator and external heat sensors



According to the hydraulic schematic

Temperature sensors (except the flue gas sensor) designed as a PT 1000 immersion sensor with a pre-connected sensor cable.

- ☞ Do not damage or bend the sensor cable
- ☞ When extending the cable, bear the minimum cross section in mind

#### 14.2.1 Flow sensor for more heat circuits

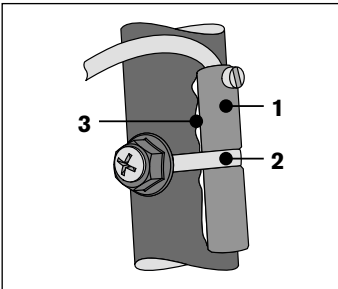

#### Position

- Approx. 50 cm after the circulating pump
- Metallic bare pipe surface
- Secure with enclosed installation material
  - Brass housing (1) and tightening strap (2) or
  - clamp (4)
- Before installing the sensor, apply the heat conducting paste (3) to the point of contact to ensure better heat transfer

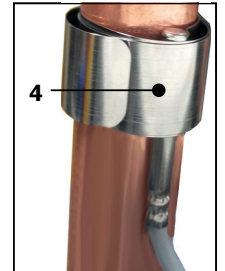

#### 14.2.2 Flue gas sensor

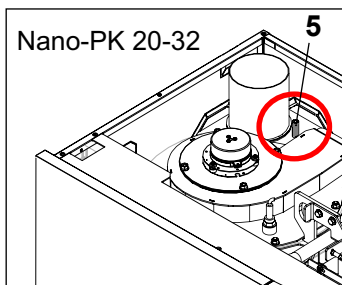

Designed as a thermocouple (type K) with a pre-connected sensor cable.

- ☞ Do not damage or bend the sensor cable
- ☞ When extending the cable, bear the minimum cross section in mind
- Insert the sensor tip into the opening (5) on the exhaust fan and secure with the spring



### 14.2.3 Boiler, HWT, accumulator and external heat sensors

- Install the sensor using the immersion sleeve
- Position the accumulator- and HWT sensor

	NOTE
Correctly position the sensors in order to control the HWT and accumulator loading processes.	

#### External HWT

Sensor resistance values

Boiler, HWT, accumulator, flow, return, outside and external heat sensors	
in °C	in Ohm
-20	922
-10	960
0	1000
10	1039
15	1058
20	1077
25	1097
30	1116
35	1136
40	1155
45	1174
50	1193
55	1213
60	1232
65	1252
70	1270
75	1290
80	1309
85	1328
90	1347
95	1366
100	1385
<b>Room temperature sensor (FR25 remote control)</b> Automatic switch position (clock) and central position of the remote adjuster (regardless of room temperature)	
<b>3340 - 3650 Ω</b>	

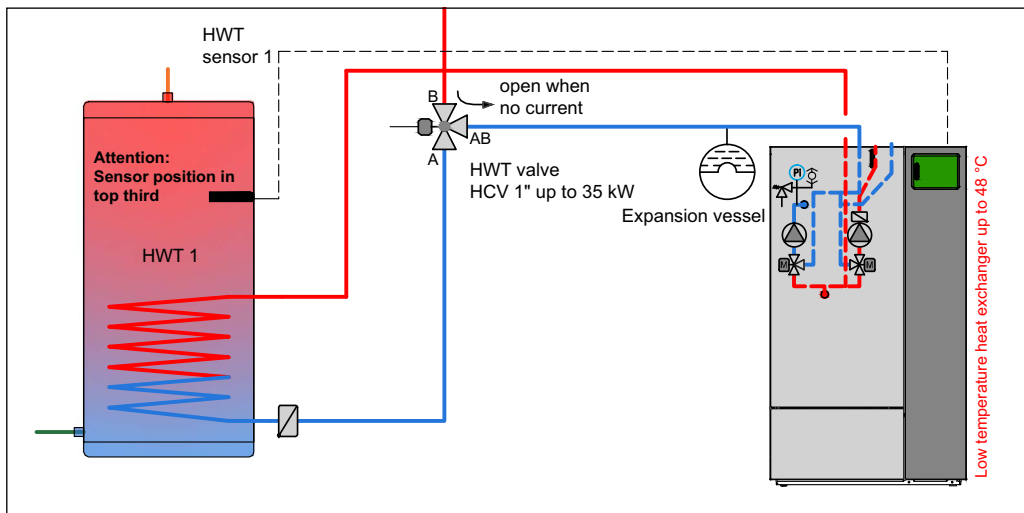

#### Accumulator with integrated HWT

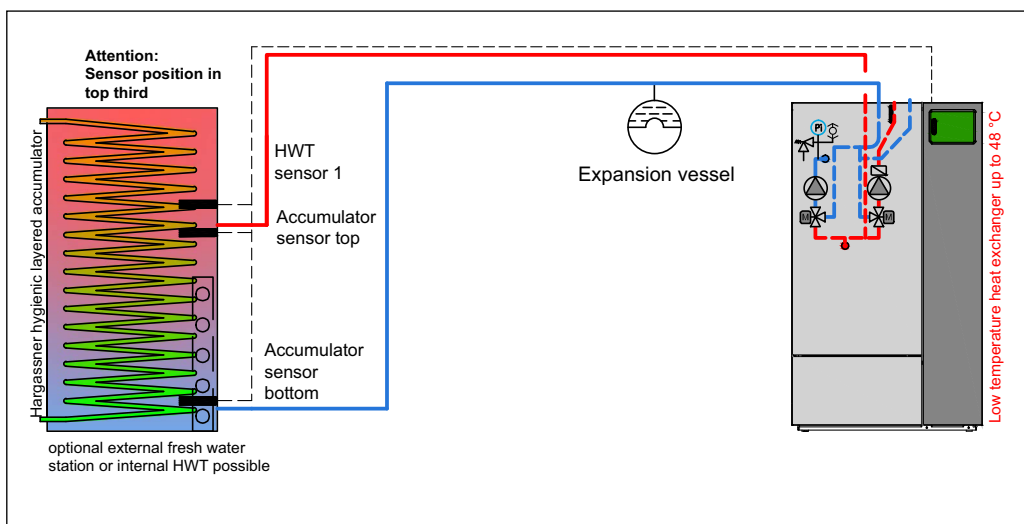

## 15 Remote control FR25 / FR35 / FR40

☞ For professional installation and operation of the remote control, see the installation and operating instructions of the respective remote control

**Caution:** In the installer settings, the corresponding remote control must be parameterised to the assigned heat circuit.

Install the remote control at an easily accessible position

### Place of installation

- No direct sunlight, draught, radiators, flue, etc.
  - ☞ Measurement of the actual room temperature
- In the most appropriate room (e.g. living room or dining room)
  - ☞ No stove (e.g. a tiled stove) may be heated in this room
  - ☞ Set the radiator thermostat to a temperature higher than the room temperature on the control unit
  - ☞ Influences the room sensor
  - ☞ Heat circuit flow is adjusted, causing other rooms to become too cold or too warm

### 15.1 FR25 remote control (analogue)



Can be used for heat circuits connected to the HKM or HKR (not for heat circuits of heat circuit board A).

#### Remote control with room sensor

Connect terminal 1 and 2 (for FR25)

#### Remote control without room sensor

Connect terminal 1 and 3 (for FR25)

#### Fault lamp

The FR25 remote control has a red LED, which can be connected to the boiler. This LED lights up on the control unit when a warning or an error is displayed.

Connect terminal 4 (+) and 5 (-) (for FR25)

### 15.2 FR35 remote control (digital)



Can be used for all heat circuits (HKM, HKR and HC A).

Bus cable 2x2x0.5 mm<sup>2</sup>, shielded and pair-twisted (e.g.: LiYCY)

☞ For cable lengths from 100 m, a cross-section of 0.75 mm<sup>2</sup>

### 15.3 FR40 remote control (digital)

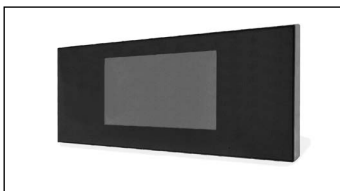

Can be used for all heat circuits (HKM, HKR and HC A).

Bus cable 2x2x0.5 mm<sup>2</sup>, shielded and pair-twisted (e.g.: LiYCY)

☞ For cable lengths from 100 m, a cross-section of 0.75 mm<sup>2</sup>

## 16 Extension module, board or controller

### 16.1 Heat circuit modules 1, 2



Up to 2 heat circuit modules may be connected to extend heat and HWT circuits. The connection to the boiler board is formed by a bus cable (on the CAN plug).

- Set the address selection switch on the extension module (default: **0**)
  - **1** for HKM 1 = heat circuit 3+4 and HWT circuit 2
  - **2** for HKM 2 = heat circuit 5+6 and HWT circuit 3

### 16.2 Additional board I/O 36 (HC AB/F, 5-sensor accumulator or differential controller)

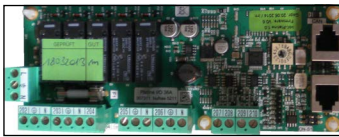

The heat circuit board is for the extension of HWT and heat circuits on the boiler. The connection to the boiler board is formed by a bus cable.

- Default address switch of the heat circuit board
  - **A** for HC A = heat circuit A and HWT circuit A
  - **B** for HC B = heat circuit B and HWT circuit B
  - **C** for AS board = 5-sensor accumulator
  - **D** for D control board = differential controller
  - **F** for HKF = controlled district line

### 16.3 Heat circuit controller HKR



Up to 16 heat circuit controllers can be connected to extend the heat and HWT circuits, as well as accumulator tanks and external heat boilers. The connection to the boiler board is formed by a bus cable (on the CAN plug).

- Set the address selection switch on the heat circuit controller (default: **1**)
  - **0** for HKR 0
  - **1** for HKR 1, etc.

## 17 Permits and reporting requirements

**Caution: Have the installation or conversion of a heating system approved by the relevant regulatory authority.**

- Report any installation or conversion to the supervising office
  - ☞ Austria: Responsible building authority
  - ☞ Germany: Chimney sweep or building authority
  - ☞ Other countries: Observe the regulations of the local authorities

## 18 Commissioning the system



### **D A N G E R**

#### **Risk of injury and/or material damage**

#### **Injuries or damage to the system due to unauthorised commissioning**

- Make sure that start-up or initial commissioning is performed by Hargassner GmbH or specially trained staff.
- Prevent unauthorised commissioning.
- Do not perform any work on the system.
- Only operate the system independently after a commissioning report has been signed.

---

**notes**

---

**notes**

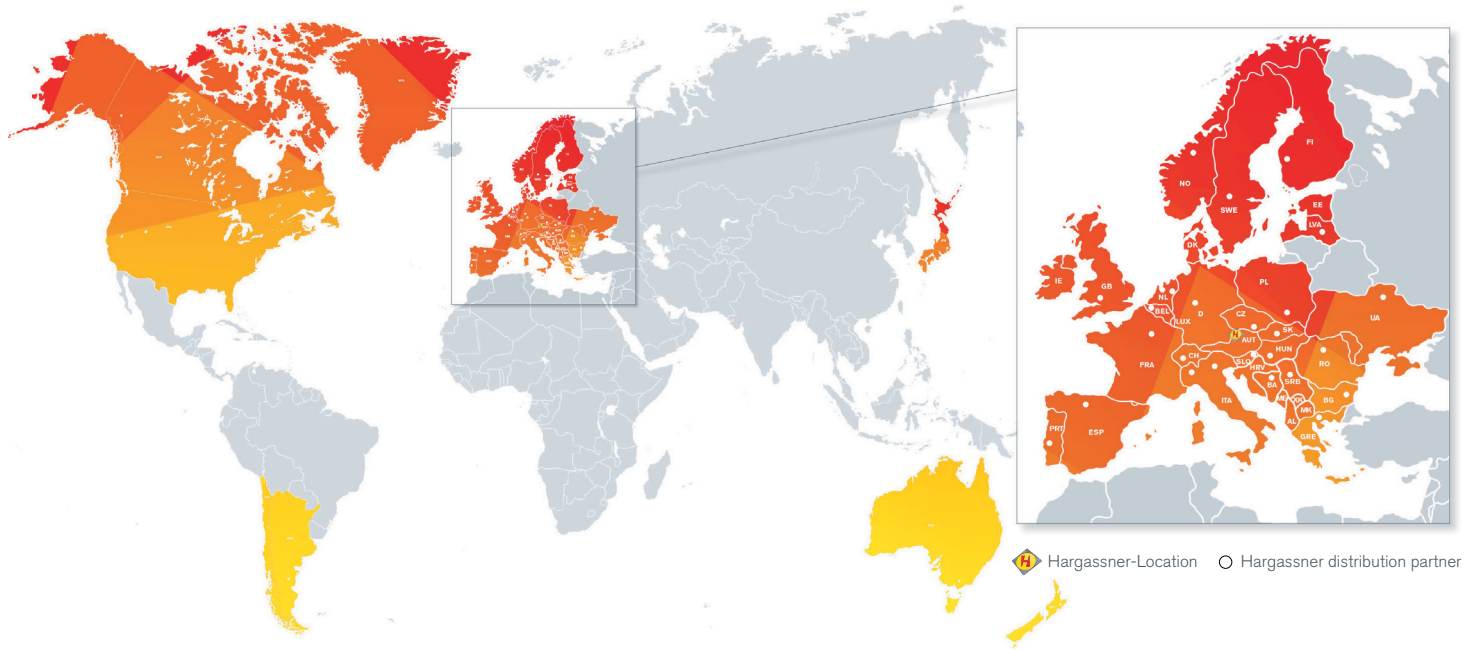

## Your expert for **SUSTAINABLE HEATING**

Complete Hargassner range: pellet boilers, wood chip boilers, wood log boilers, accumulator tanks, industrial boilers up to 2.5 MW, heating modules, filling augers, Power-Box warm-air module, heat pumps, solar panels and hydraulic accessories

**HARGASSNER Ges mbH**  
Anton Hargassner Straße 1  
4952 Weng im Innkreis  
AUSTRIA  
+43 77 23 52 74 - 0  
office@hargassner.at

[hargassner.com](http://hargassner.com)