

# Operation manual Pellet Boiler Nano-PK 6-15

**HARGASSNER**  
HEIZTECHNIK DER ZUKUNFT



**Follow and store this manual**

**HARGASSNER Ges mbH**

A 4952 Weng, Upper Austria  
Tel.: +43/7723/5274-0  
Fax: +43/7723/5274-5  
office@hargassner.at  
www.hargassner.com

EN - V06 02/2022 - 11058854

# Contents

---

<b>Chapter I: Technical Data</b>	<b>5</b>
1 Dimensions .....	5
2 Intended use .....	5
3 Seasonal space heating emissions .....	5
4 Fuel quality .....	5
5 Boiler room design .....	6
6 Design of the fuel storage room .....	6
7 Design of heat circuits .....	7
8 Flue pipe - chimney connections .....	7
9 Electrical supply .....	8
<b>Chapter II: Safety regulations</b>	<b>9</b>
1 General safety regulations .....	9
2 Remaining risks .....	10
3 Measures in case of danger .....	12
<b>Chapter III: Operation</b>	<b>13</b>
1 Overview of boiler components .....	13
2 Prior to commissioning .....	14
3 Control unit .....	16
4 Operating modes .....	19
5 System status indicators .....	20
6 Info menu .....	23
7 Manual operation .....	27
8 Settings menu .....	31
9 Customer settings .....	34
10 Commissioning settings .....	40
11 Optional remote controls .....	53

<b>Chapter IV: Cleaning</b>	<b>55</b>
1 Maintenance contract .....	56
2 Cleaning .....	57
3 Disposal information .....	63
<b>Chapter V: Troubleshooting</b>	<b>64</b>
1 Information and error display .....	64
2 Viewing the error list .....	64
3 Acknowledging and rectifying an error .....	64
4 BCE failure .....	65
5 Temporary emergency operation (restart without HW test) ....	65
6 Combustion error No. 0029 .....	65
<b>Appendix</b>	<b>67</b>
1 Copyright notice .....	67
Declaration of Conformity .....	68

---

## Dear customer!

Thank you for choosing an innovative wood biomass boiler from our company. This boiler from Hargassner Ges mbH is a state-of-the-art product and manufactured to the latest production standards. We are very pleased about your decision and guarantee that you've chosen a reliable quality product.

However, as important as the products' high performance is, a professional installation, commissioning and service is just as crucial. Supportive are attached hydraulic schematics, and connections- and installation drawings. To ensure a long service life, exactly read and follow this operation manual. High costs for reparation and long downtimes may be prevented.

### Keep this manual within easy reach.



This operating manual is intended to help:

- you familiarise yourself with the boiler
- you use it for its intended purpose

This manual contains important information on operating the boiler

- Safely
- Properly
- In an environmentally friendly manner
- Economically

Guidelines within this manual will:

- Prevent hazards
- Reduce breakdowns and wear
- Increase the reliability and lifetime of the boiler

# Chapter I: Technical Data

## 1 Dimensions



Designation	Description	Value	Unit
B	Total width	780	mm
T	Total depth	580	mm
H	Total height	1605	mm
	Total weight	220	kg

## 2 Intended use

The automatic wood pellet boiler is designed to heat up water only. Only fuels permitted by Hargassner may be burned in this system. Only use the boiler in technically perfect working order. Rectify errors immediately. Proper use also includes observing all items in this manual and adhering to the inspection and maintenance instructions.

## 3 Seasonal space heating emissions

Carbon monoxide	< 500 mg/m <sup>3</sup>
Nitrogen oxide	< 200 mg/m <sup>3</sup>
Gaseous organic compounds	< 20 mg/m <sup>3</sup>
Dust	< 40 mg/m <sup>3</sup>

Seasonal space heating emissions at 10% residual oxygen in dry flue gas

## 4 Fuel quality

Only use fuels that comply with **EN ISO 17225-2**

	<b>WARNING</b>
	<ul style="list-style-type: none"> <li>☞ Only use released and permitted fuels</li> <li>☞ Always consult Hargassner before using new fuels</li> <li>☞ Have Hargassner check the usability</li> </ul>

### 4.1 Pellets (A1)

Ensure quality standards are adhered to when pellets are ordered and delivered

- Least possible dust content
- Pellets with a hard and shiny surface
- 100% natural wood, no additives, etc.
- Pellets class **A1** defined in **EN ISO 17225-2** and **EN ISO 20023**

Calorific value	Density	Diameter	Length	Fine material rate
≥ 4.6 kWh/kg	600 - 750 kg/m <sup>3</sup>	6 ±1 mm	3.15 - 40 mm	≤ 1%

## 4.2 Inadmissible fuels

- Fuel with water content >35%
  - ☞ Formation of condensate
  - ☞ Increased corrosion in the boiler
- Paper, cardboard
- Chip boards, impregnated timber
- Black coal, brown coal or lignite
- Waste
- Plastics

## 5 Boiler room design

Boiler rooms must be designed in accordance with local regulations.

⇒ See "[Design of boiler room](#)" in the installation manual

- Keep the system air inlets clear
- Never store flammable materials in the boiler room
- Design the boiler room to be frost-proof
- Maximum ambient temperature up to 40°C
- Ensure fireproof, level and solid floor and ceiling construction
- In accordance with regulations, have the main heating switch installed by an electrician (depending on building regulations)
- Fire extinguisher

## 6 Design of the fuel storage room

Design your pellet fuel storage room in accordance with local regulations (e.g. EN ISO 20023 or VDI 3464).

⇒ See "[Design of the fuel storage room](#)" in the installation manual

- Only install metal fill pipes, electrically grounded and connection to atmosphere
- Consider noise protection for wall openings
- Protection against moisture, water and dust
- Correctly position impact protection mat and install slant floor

<b>D A N G E R</b>	
	<p><b>Risk of explosion or suffocation</b></p> <p><b>Risk of suffocation from odourless carbon monoxide in the storage room</b></p> <ul style="list-style-type: none"><li>• Ventilate sufficiently before entering the storage room</li><li>• Keep a window/door open while in the storage room</li><li>• Position second person outside to supervise</li></ul> <p><b>Dust explosions in the storage room due to the explosive combustion of pellet dust</b></p> <ul style="list-style-type: none"><li>• Pay attention to proper grounding of transportation tubes</li><li>• No motors in the storage room<ul style="list-style-type: none"><li>☞ Except agricultural buildings</li></ul></li><li>• No other ignition sources (light) in the storage room</li><li>• No electrical equipment (switches) in the storage room</li><li>• No welding work in dusty environments</li></ul>

## 7 Design of heat circuits

Proper design of the heat circuits is essential for optimum boiler operation.

⇒ **Authorised hydraulic schemes: see enclosed hydraulic schemes**

Accumulators, pumps and mixers for heat circuits must be designed according to current standards by the commissioning engineer

## 8 Flue pipe - chimney connections

Description	Unit	Nano-PK 6	Nano-PK 9	Nano-PK 10	Nano-PK 12	Nano-PK 15
Nominal heating output	KW	6.6	9	10.5	12	15
Flue gas temperature	°C	130				
CO <sub>2</sub>	%	14				
Flue gas mass flow rate	kg/sec	0.0037	0.0050	0.0058	0.0066	0.0083
Req. delivery pressure	Pa	2				
Available fan delivery pressure during AIO	Pa	5				
Flue draft max. limit	Pa	10				
Diameter of flue pipe connection	mm	100				

	<b>A T T E N T I O N</b>
	<p><b>Installing a flue draught stabiliser</b>                  A flue draught stabiliser with an explosion protection flap (set to 10 Pa) must be installed in the chimney or flue pipe.</p>

	<b>N O T E</b>
	<p><b>After a soot fire, clean your flue pipes and replace all the flue pipe seals</b>                  ☞ Optimum seal tightness for the flue pipes and chimney connections</p>

## 9 Electrical supply

⇒ See enclosed electrical manual

Electrical energy	Characteristics	Unit
Voltage	230	V ± 5 %
Frequency	50	Hz ± 5 %
Back-up fuse	13	A
Power consumption <sup>a</sup>	max. 38	W





a. Calculated in accordance with the EN 303-5 testing requirements without the pumps and fuel extraction system

- The electrical supply may only be established by a licensed and authorised electrician and must be in accordance with the enclosed electrical manual
- Attach a lockable main power switch outside the boiler room (as per building regulations)
- Max. back-up fuse **13 A** (C type)
- It is absolutely imperative that the intrinsically safe cables are **permanently installed**
  - Use suitable mechanical fixing material
- Establish mains supply **L** and **N** (see electrical manual)
- Connect equipotential bonding conductor
- Use highly flexible cables (e.g. **H05VV-F**)

## Chapter II: Safety regulations

### 1 General safety regulations

#### 1.1 Obligation to instruct, external visitors and children

<b>D A N G E R</b>	
    	<p><b>Danger to life</b></p> <p><b>Risk of death, injuries, damage from improper operation</b></p> <ul style="list-style-type: none"> <li>• Observe the safety instructions of the system/boiler and in the operation manual</li> <li>• Read the user manual prior to commissioning           <ul style="list-style-type: none"> <li>☞ There is a storage compartment in the cladding door</li> </ul> </li> <li>• Only let qualified and experienced staff work on the system/boiler</li> <li>• Decide who is responsible for managing the system/boiler</li> <li>• Keep external, unauthorised and untrained people away from the system/boiler and the fuel storage room</li> <li>• Do not disclose control entry codes</li> <li>• Observe legal minimum age of staff</li> <li>• Place prohibition sign on boiler room door and fuel storage door</li> </ul> <p><b>Risk of suffocation from odourless carbon monoxide</b></p> <ul style="list-style-type: none"> <li>• Ventilate sufficiently before entering the storage room</li> <li>• Keep window/door open while inside</li> <li>• Always have a second person outside to supervise</li> </ul>

Work on the boiler's electrical parts must only be carried out by an electrician and in accordance with the electrical engineering regulations.



Work on hydraulic systems must be carried out only by personnel with specialised knowledge and experience in heating engineering and pipework construction.





#### 1.2 Special measures prior to commissioning by the operator

- Licensing requirements for safe operation and accident prevention regulations must be observed!
- Carry out the required checks prior to commissioning
  - ⇒ See "Checks prior to commissioning" on page 14.
- Carry out the required checks before switching the system/boiler on
  - ⇒ See "Inspections before starting up the boiler" on page 15.

### 2 Remaining risks

The following residual risks must be particularly taken into account when the system is operated properly and in accordance with its intended purpose:

	<p style="text-align: center;"><b>D A N G E R</b></p> <p><b>Risk of burns or scalding</b></p> <p><b>Burns due to hot surfaces or hot ash</b></p> <ul style="list-style-type: none"> <li>• Shut down the plant prior to any maintenance- or service works and let system/boiler cool down</li> <li>• Do not reach into the system/boiler during operation</li> <li>• Wear heat resistant safety gloves                             <ul style="list-style-type: none"> <li>☞ The ash in the ash container stores heat</li> </ul> </li> <li>• Do not empty hot ash into dustbin                             <ul style="list-style-type: none"> <li>☞ Put ash in closed, not-flammable vessels only</li> </ul> </li> </ul> <p><b>Scalds due to sprinkling, hot water</b></p> <ul style="list-style-type: none"> <li>• Check all hoses, lines and connections periodically for leakages, wear and tear or any other damage</li> <li>• Rectify damage immediately</li> <li>• Before performing any maintenance work on the water circulation system, depressurise the boiler</li> <li>• Check that all valves are in the correct position</li> </ul>
	<p style="text-align: center;"><b>D A N G E R</b></p> <p><b>Dust explosion due to electro-static charging in the storage room</b></p> <ul style="list-style-type: none"> <li>• Pay attention to proper grounding of transportation tubes</li> <li>• No motors in the storage room (acc. to country-specific regulations)                             <ul style="list-style-type: none"> <li>☞ Except agricultural buildings</li> </ul> </li> <li>• No other ignition sources (light) in the storage room</li> <li>• No electrical equipment (switches) in the storage room</li> <li>• No welding works in dusty environment</li> </ul>
	<p style="text-align: center;"><b>D A N G E R</b></p> <p><b>Risk of deflagration, explosion and fire</b></p> <p><b>Burns from explosive combustion of residual gases (CO) in the combustion chamber</b></p> <ul style="list-style-type: none"> <li>• Open the maintenance door carefully                             <ul style="list-style-type: none"> <li>☞ At first, open door only slightly</li> <li>☞ Keep your body and face away from the maintenance door</li> </ul> </li> <li>• Do not open the maintenance door during or straight after a power blackout                             <ul style="list-style-type: none"> <li>☞ The risk of deflagration increases significantly after uncontrolled boiler conditions (e.g. power loss)</li> </ul> </li> <li>• Do not open the maintenance door in heating mode</li> </ul>

 	<p style="text-align: center;"><b>D A N G E R</b></p> <p><b>Risk of injury</b>  <b>Risk of crushing and amputation due to moving parts</b></p> <ul style="list-style-type: none"> <li>• Refrain from accessing augers or motors when the boiler is switched on</li> <li>• Do not work on the boiler while people are in the danger zone             <ul style="list-style-type: none"> <li>☞ Secure / lock storage room</li> </ul> </li> <li>• Observe storage room sticker</li> <li>• Only clean the augers and remove blockages using suitable tools and when the main power switch is turned off</li> <li>• Wear safety shoes</li> </ul>
	<p style="text-align: center;"><b>D A N G E R</b></p> <p><b>Danger to life</b>  <b>Electric shock from contact with live terminals</b></p> <ul style="list-style-type: none"> <li>• Observe information signs</li> <li>• Before starting work, check that no voltage is present using a voltmeter</li> </ul>
	<p style="text-align: center;"><b>D A N G E R</b></p> <p><b>Risk of poisoning or suffocation</b>  <b>Death, poisoning or suffocation due to flue gas in the boiler room / building</b></p> <ul style="list-style-type: none"> <li>• Check boiler doors and seals for leaks</li> <li>• Burning treated wood (paints, varnishes, waterproofing) creates toxic ash             <ul style="list-style-type: none"> <li>☞ Avoid skin and eye contact</li> </ul> </li> </ul>
	<p style="text-align: center;"><b>D A N G E R</b></p> <p><b>Risk of injury</b>  <b>Risk of injury and/or damage due to unexpected operating conditions</b></p> <ul style="list-style-type: none"> <li>• When working in manual mode, limit switches and motors are not automatically monitored             <ul style="list-style-type: none"> <li>☞ Only run the augers backwards briefly (max. 2 seconds)</li> </ul> </li> <li>• Allow trained staff only to manually operate the boiler</li> </ul>

## II Safety regulations

---

### 3 Measures in case of danger

#### 3.1 Fire in the boiler room

- Switch off the main heating switch before fighting any fires
  - ☞ Disconnect the main power supply
- Switch off main power switch and disconnect power supply to boiler room

#### 3.2 After a power outage

Do not open the boiler's doors or reach into it during a power failure.

- ☞ Danger of deflagration
- ☞ Danger of crushing by the augers

After the electrical supply is switched on again, the control starts in **Heat up** mode and monitors the flue gas temperature.

- ☞ If the flue gas temperature rises, the system heats up and regulates the transfer of heat according to the preset parameters

#### 3.3 Leak in heating water system

When the water pressure is too low, not enough heat is transferred from the boiler to the heat circuits, the HWT and the accumulator.

- ☞ Danger of boiler overheating
- Stop heating up the boiler
- Fix leak
- Fill / refill water circulation system
- Check water pressure

#### 3.4 Leaks in the system (escaping flue gas)

- Stop heating up the boiler
- Check the seals of the doors and cleaning covers, and have them replaced

#### 3.5 Auger blockages

Do not touch the blocked augers.

- ☞ Danger of crushing from sudden release of blockage
- Briefly run the blocked auger backwards in manual mode (max. 2 seconds)
  - ☞ Danger of fuel being compressed in the auger
- Only clean the augers and remove blockages using suitable tools and when the main power switch is turned off and locked

## Chapter III: Operation

### 1 Overview of boiler components

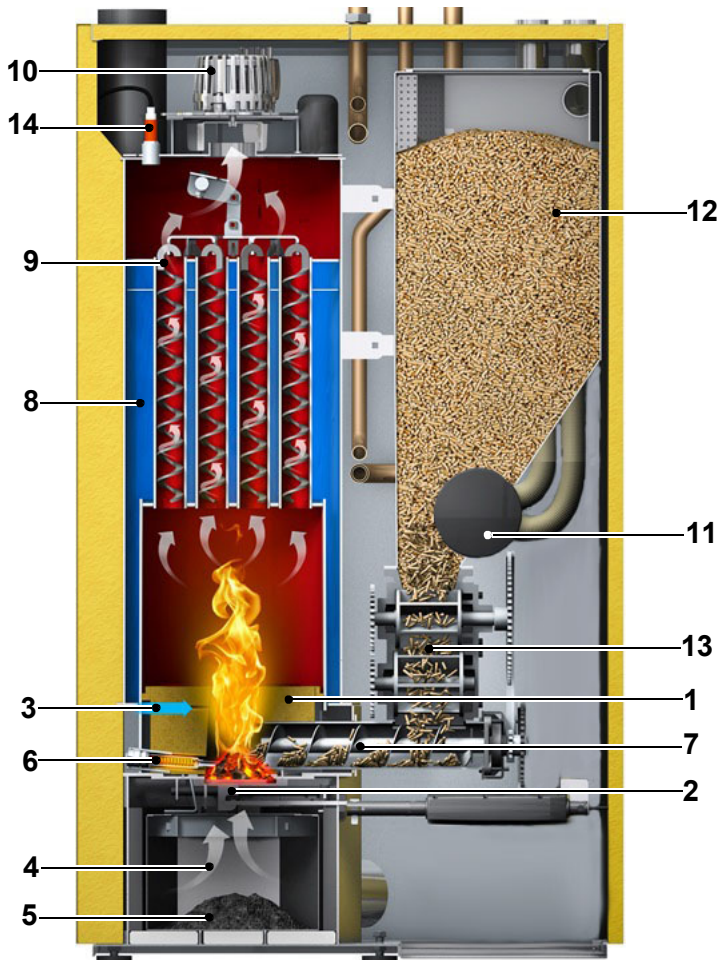

Item	Description
1	Fully refractory-lined combustion
2	Sliding grate
3	Secondary air stream with inlet channels
4	Primary air
5	Ash pan
6	Automatic ignition
7	Stoker auger
8	Heat exchanger
9	Turbulators with automatic boiler cleaning device
10	Exhaust fan
11	Wood pellet vacuum turbine
12	Pellet day hopper with fill level indicator
13	Double rotary valve
14	Lambda sensor

The system consists of the combustion chamber and the heat exchanger, and controls the combustion air with the exhaust fan.

The lambda sensor consistently monitors the flue gases. The integrated sensors monitor the temperatures of the system and the flue gas. The turbulators clean the heat exchanger using a rod. The sliding grate cleans itself automatically and transports combustion residues into the fully integrated ash pan. The pellets are ignited by the automatic ignition.

#### 1.1 Function

- Fuel transport from the storage room
- Transport of the fuel into the combustion chamber
- Ignition and combustion of the fuel
- Control of heat transfer to the heating-water system
- Cleaning of the boiler and the ash extraction into the box
- Evacuation of the flue gases

## 2 Prior to commissioning

	<p style="text-align: center;"><b>D A N G E R</b></p> <p><b>Danger to life and risk of material damage</b>  <b>Death, personal injury and/or damage due to missing, defective or bypassed safety devices or system parts</b></p> <ul style="list-style-type: none"> <li>• Check safety devices and boiler parts carefully to ensure they are working properly and as intended</li> <li>• Never modify or bypass safety devices</li> <li>• Perform repair measures immediately in case of a malfunction or defect</li> <li>• Place, position and function of all safety devices must be known</li> </ul>
	<p style="text-align: center;"><b>D A N G E R</b></p> <p><b>Risk of injury</b>  <b>Injury and/or damage due to unexpected operating states</b></p> <ul style="list-style-type: none"> <li>• Make sure that commissioning/start-up is performed by Hargassner GmbH or specially trained staff</li> </ul>
	<p style="text-align: center;"><b>W A R N I N G</b></p> <p><b>Risk of injury</b>  <b>Danger of crushing from moving parts in the vicinity of the fuel extraction system, de-ash system and grates</b></p> <ul style="list-style-type: none"> <li>• Make sure that no persons are in the boiler's danger zone</li> <li>• Do not reach into any reachable mechanical parts</li> <li>• Do not stand on the boiler</li> <li>• Do not leave any foreign parts (tools, etc.) in the boiler</li> </ul>

### 2.1 Checks prior to commissioning

- Safety on-site and plumbing and electrical installations
- Correct assembly of the boiler/system
- Check all necessary components
  - Check tightness, proper function, rotation of all motors, etc.
  - Check correct position of combustion chamber lining

### 2.2 Commissioning

Once the boiler has been installed properly and all the required safety devices have been checked, the boiler can be commissioned in accordance with the commissioning checklist in the inspection book.

	<p style="text-align: center;"><b>A T T E N T I O N</b></p> <p>The boiler must be commissioned by an engineer with a Hargassner commissioning certificate. The completed commissioning checklist must be sent back to Hargassner with the commission number within 30 days of commissioning, <b>otherwise the warranty becomes void</b>. A copy remains in the commissioning book on-site.</p>
---	--

## 2.3 Customer instructions

- Explain cleaning and maintenance intervals
- Explain inspections prior to any fuel refill
- Explain how to operate the boiler and resolve issues

## 2.4 Starting the boiler for the first time

The boiler can be started for the first time once commissioned.

- Switch the boiler to manual mode
  - ☞ Use parameter no. 8 to fill the day hopper in manual mode
    - ☞ Prevents an error due to missing fuel
- Switch the system to **Auto** mode
  - ☞ Boiler starts automatically when hot water is needed



## 2.5 Inspections before starting up the boiler

- Check water pressure in boiler, heat, HWT and accumulator circuits
- Pay attention to the display for notifications (error messages and operating status)
- Rectify any errors
- Check and lock the fuel storage room

## 2.6 Filling the fuel storage room

	<b>A T T E N T I O N</b>
	<p><b>Fire hazard</b></p> <p><b>Danger of flue gas suctioned out of the system</b></p> <p>☞ Always switch off the system before blowing pellets into the storage room</p> <p><b>Protect fuel against moisture</b></p>

### 3 Control unit

DANGER	
 	<p><b>Incorrect operation of the control unit</b></p> <p><b>Risk of injury and damage to the boiler due to unexpected operating states</b></p> <ul style="list-style-type: none"> <li>• Only allow trained staff to operate the control unit</li> <li>• Access to all functions of the control unit is protected by codes           <ul style="list-style-type: none"> <li>☞ Service settings and commissioning settings</li> <li>☞ Codes may not be disclosed to third parties</li> </ul> </li> </ul>

#### 3.1 Home view

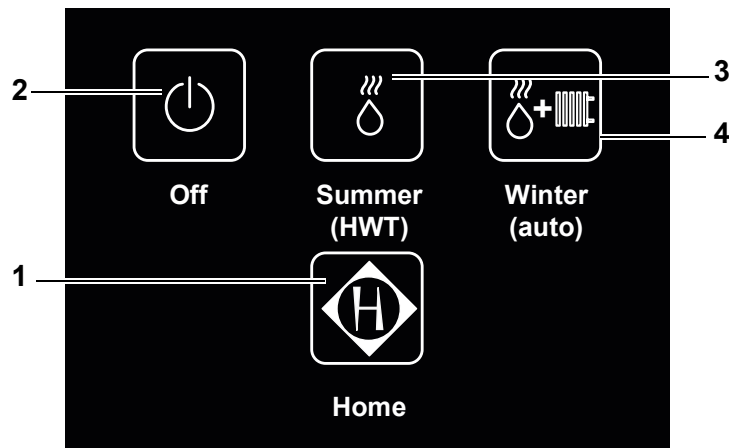









Item	Description	Function
1	Standard menu	Switching from <b>Home</b> to the <b>Standard menu</b> ⇒ See "Standard menu view" on page 18.
2	Operating mode <b>Off</b>	Quick select button for operating mode <b>Off</b> ⇒ See "Operating modes" on page 19.
3	Operating mode <b>Summer</b>	Quick select button for operating mode <b>Summer</b> (HWT mode)
4	Operating mode <b>Winter</b>	Quick select button for operating mode <b>Winter</b> (Automatic)

☞ After the time set in the **No. 02 Display settings** setup parameter has elapsed, the control unit automatically switches to the Home view

## 3.2 Touchscreen

The control unit is designed as a touchscreen.

☞ It is operated using finger pressure on the display

- ☐ Scroll through the menu with  
- ☐ To return to the previous menu, press  **Standard**
- ☐ To return to the Standard menu, press  **Standard** (you may have to press 2x)
  - ☞ Possible from every menu
- ☐ Activate the operating mode by pressing the  **Function selection** button
- ☐ Press the field to activate the input field
  - ☞ Values are displayed in **red**
- ☐ Change the active values:  
  - ☞ Values flash **red**
  - ☞ Buttons flash **green**
- ☐ To enter or save any changes, press 
- ☐ You can go straight to the customer parameters by pressing the relevant graphic in the standard menu
  - ☞ Possible with the system, accumulator, HWT, external heat boiler and heat circuit graphics

### 3.3 Standard menu view

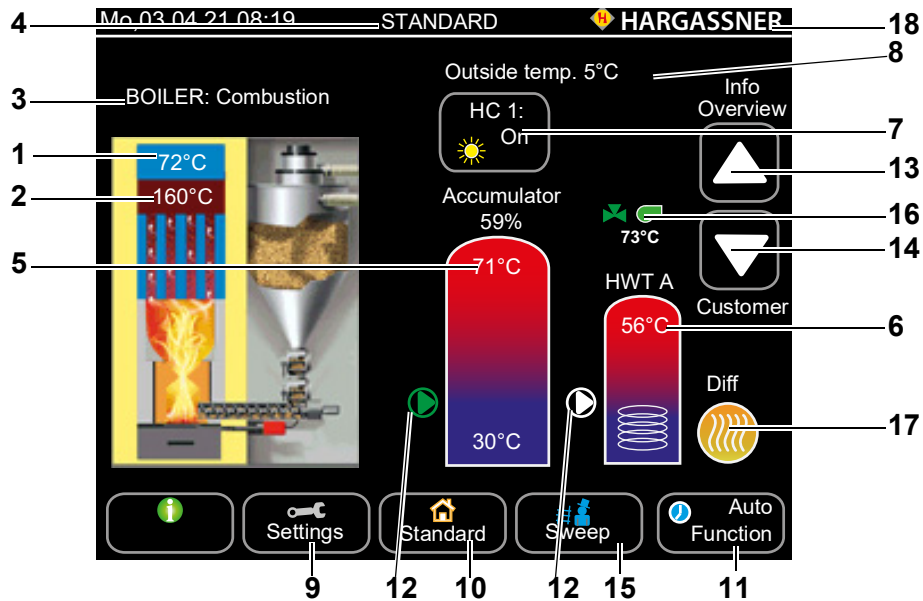

Item	Description	Function
1	Boiler temperature	Displays the current boiler temperature
2	Boiler flue gas temperature	Display of the current flue gas temperature
3	Status display of the boiler	⇒ See "System status indicators" on page 20.
4	Status display of the control unit Display of the current menu name	<ul style="list-style-type: none"> <li>• Description of the active menu</li> <li>• Error (flashes red) / notices (yellow)</li> <li>• Current position in menu tree</li> <li>• <b>Boiler stop</b> in days</li> </ul>
5	Temperature display in accumulator tank (if available) Display of accumulator filling volume in [%]	Current temperatures (top, mid, bottom) of connected accumulator sensors Currently filled heat capacity
6	HWT temperature indicator	Display of the current water temperature in the HWT
7	Status display of heat circuits	<ul style="list-style-type: none"> <li>• <input type="checkbox"/> Off - Heat circuits switched off</li> <li>•  Sun - Heat circuits in day mode</li> <li>•  Moon - Heat circuits in reduced mode</li> <li>•  Frost - Heat circuits in frost protection mode</li> </ul>
8	Display of outside temperature	Outside temperature measured with outdoor sensor
9	Settings	Takes you to the customer, commissioning engineer and service settings and to the control unit setup menu.
10	Standard	Displays the standard menu. You can switch directly to the Standard menu from any menu. After 10 minutes of no activity, the display automatically switches back to the <b>Standard</b> display menu
11	Function	Select boiler operating mode. ⇒ See "Operating modes" on page 19.
12	Pump	Pump operating mode Green: pump is running; white: pump has stopped
13	Info	<ul style="list-style-type: none"> <li>•  Switching to the Info menu</li> </ul>
14	Customer	<ul style="list-style-type: none"> <li>•  Switching to the customer settings</li> </ul>
15	Test mode (chimney sweep)	By pressing the <b>Test mode</b> button, a special boiler status programme is started to measure the flue gas consistency
16	External heat boiler	Status display of external heat boiler (if available) Green: released; white: locked
17	Differential control	Pressing the symbol will take you to the differential control info page
18	Hargassner logo	Press on the logo to display the boiler data

## 4 Operating modes



Auto  
Function



Hot water  
tank  
Function



Off  
Function



Manual  
Function

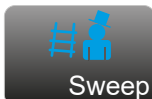

Sweep



F. Off

- **Automatic (Auto):** The standard mode in which the heating system is operated according to the preset temperatures and on/off times
- **Hot water (HWT):** The heating system is only used to ensure the hot water supply, not to heat any floor heating system or radiators
  - ☞ Heat circuits are not controlled (except for frost protection function)
  - ☞ Pumps **Off** and mixers **Closed**
- **Switch off (Off):** The heating system is switched off - with the exception of the frost protection function. The touchscreen continues to show all current information
  - ☞ Heat circuits are not controlled (except for frost protection function)
  - ☞ Pumps **Off** and mixers **Closed**
- **Manual mode (Manual):** Allows various actions to be carried out manually, such as manual activation of individual pumps and mixers. Also shows additional information and values.  
The standard display is retained in the Automatic, Hot water and OFF operating modes
- **Test mode:** The button for the chimney sweep to manually switch the boiler **On** or **Off** during emission tests  
The following options are available:
  - ☞ **Full load:** If an accumulator is connected, press this button to have the control unit automatically change to full load measurement
  - ☞ **Empty accumulator:** Press this button to switch off all the boiler's programmed control functions. The boiler operates at full load, assumes very low outdoor temperatures and tries to transport as much as possible heat into the heating system. All regulating devices like thermostatic valves and automatic control valves have to be opened manually to ensure that the required amount of heat is transferred. This function ends automatically after 2 hours. If the **Test mode** button is pressed and no accumulator is connected, the control unit offers two options: **full-load measurement** and **partial-load measurement**. All programmed control functions are switched off in the partial load measurement function. The boiler controls up to full load. After 15 minutes of full load, output is reduced to 50% (partial load). After 5 minutes of partial load, the message "**Start test mode measuring**" will appear on the display
- **Firing OFF:** Button for switching firing off. Firing can be switched off immediately or at a preset time
  - ☞ Control of the heating circuits with the pumps and mixer continues; only firing is switched off

## 5 System status indicators

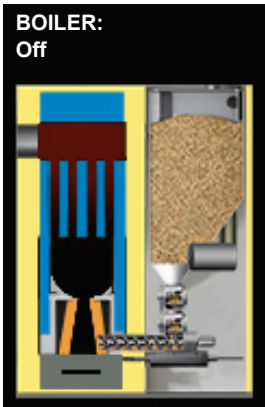

The control unit uses the temperatures and flue gas values to detect the status of the boiler.

### Off

The boiler switches off if there is no demand from the heat circuits or HWTs or if the accumulator takes care of the demand.

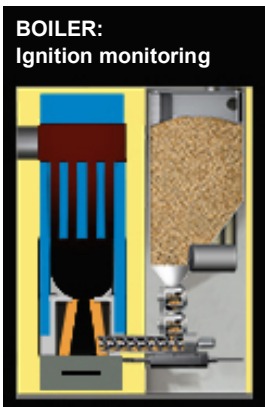

### Ignition monitoring

Fuel is transported into the combustion chamber and the boiler monitors if autonomous ignition occurs due to residual embers.

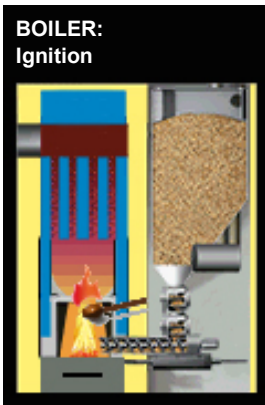

### Ignition

The electric ignition starts and the fuel is ignited.



### Combustion

The boiler controls exhaust fan output (air volume) according to the heat demand and required boiler temperature, and the optimum fuel amount according to the lambda sensor signal.

☞ Combustion output range from 30-100%

### Burnout

The system controls the burnout according to the O<sub>2</sub> content and the set minimum and maximum burnout times.

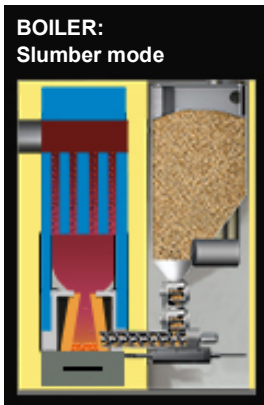

### Slumber mode

If the heat demand drops below the minimum boiler output, the system switches to slumber mode.

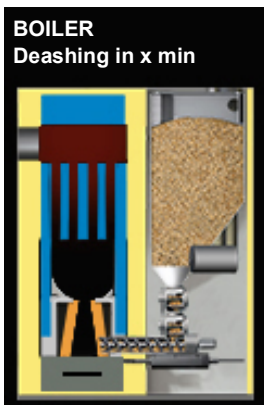

### De-ash in x min

When the maximum combustion time is reached, the combustion chamber is "burnt out".

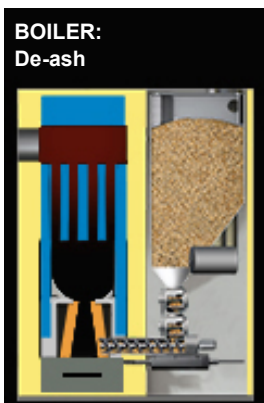

### De-ash

The grate is opened and closed again twice. The ash drops into the ash pan. The boiler returns to the required state afterwards.

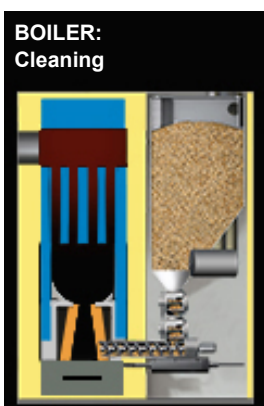

### Cleaning

After each de-ash cycle (Parameter Q12) the grate opens completely and the cleaning spirals clean the heat exchanger.

☞ The ash falls into the ash pan and the boiler returns to the required status afterwards

**BOILER:**  
Fill pell. in 7 min

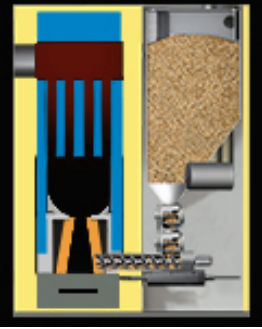

### Filling pellets in

If the minimum auger runtime and the set suction time are reached or the maximum auger run time is exceeded, the filling will be started after the displayed time.

**BOILER:**  
Refill pellets

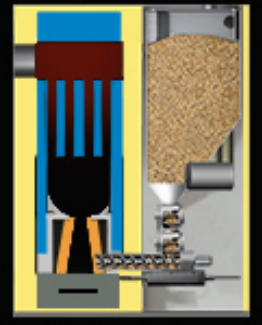

### Refill pellets

The pellet vacuum turbine is started and the day hopper is filled with pellets again. The system returns to the required state afterwards.

**BOILER:**  
ABS

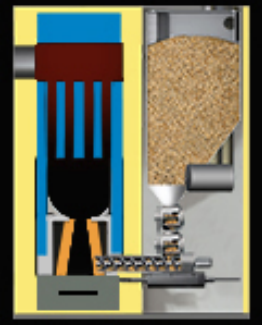





### ABS Automatic blockage protection

Exhaust fan and cleaning device are started (duration 10 seconds). The touch screen displays **CAUTION, ABS function is starting.**

- ☞ During the **ABS** state, do not switch off the boiler, do not open the boiler's doors or reach into the boiler

## 6 Info menu

- Press  in the **Standard** menu
- Use arrows to move within the menu    
Target: Adjustment value / target value  
Actual: Current value (position)
- In the respective Info menu, press the  symbol to go straight to the settings

### 6.1 Overview

Mo.03.06.21 08:19		HARGASSNER
Fill level		Full
Heat circuit A		Reduction
Heat circuit 1		Reduction
Heat circuit 2		Reduction
Heat circuit 3		Reduction
HWT A		Off
HWT 1		Off
Accumulator		Off
Ash box		OK

Shows an overview of heat circuits, HWTs and any other components of the individual heating system.

### 6.2 District line pump

Mo.25.11.21 08:19		HARGASSNER
District line pump 1		On
Pump		

If a heat circuit has a district line, the status of the district line pump is shown on this page (green = **On**, white = **Off**).

### 6.3 Heat circuits

Shows the status of the heat circuits. One heat circuit is displayed per page. If there are several heat circuits, several info pages are available in the menu. If the mixer pump is running, this is indicated as text and by a green arrow icon.

- Use the symbol next to the heat circuit **(1)** to access the configuration pages
- You can also press the heat circuit button in the standard view directly to go to the first heat circuit page
-  If a FR25, FR35 or FR40 is used, it is shown in an additional line
- Select the heating mode using the heating mode symbol **(2)**

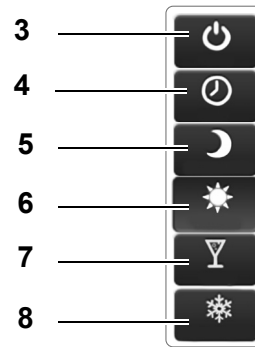
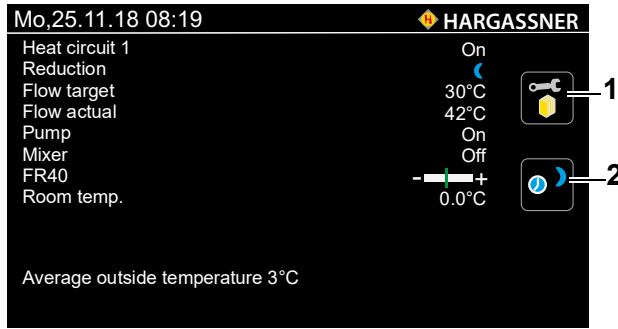

Item	Description	Function
1	Heat circuit configuration	The button next to the corresponding heat circuit is used to jump to the setting options in the configuration pages
2	Heating mode configuration	The button is used to enter the pop-up menu for selecting the heating mode
3	Off	Heat circuit is switched off (except for frost protection function)
4	Automatic	Heat circuit runs according to the timer programme's settings
5	Continuous reduction	The room temperature is continuously being reduced to the preset room temperature (reduction mode)
6	Continuous heating	The room temperature is continuously being heated to the preset room temperature (heating mode)
7	1x heating	The heat circuit heats the room temperature to the target value (heating mode) and switches back to the automatic timer programme during the next heating cycle (or after 24 hours at the latest)
8	1x reduction	The heat circuit reduces the room temperature to the target value (reduction mode) and switches back to the automatic timer programme during the next heating cycle (or after 24 hours at the latest)

## 6.4 Hot water tank

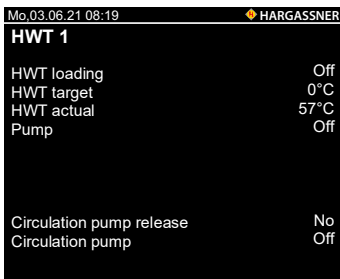

Info page about the HWT status

- HWT loading
- Target temperature
- Actual temperature
- HWT fill level display
- Pump status



If more HWT are parametrised, more info pages are also available. The circular arrow symbol next to the HWT graphic shows if the HWT pump is running or not (green: On, white: Off).

☞ Use the HWT icon to access the HWT setting options in the configuration pages

- **One-time charge** button 

☞ Press the button to recharge the HWT once to its target temperature

## 6.5 Differential control

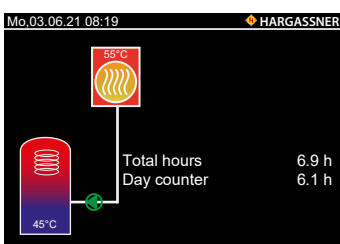

Info page about the current status of differential control

- Differential control operating hours
- Total / day
- Current heat source temperature
- Current temperature at differential sensor (S2)

## 6.6 Boiler

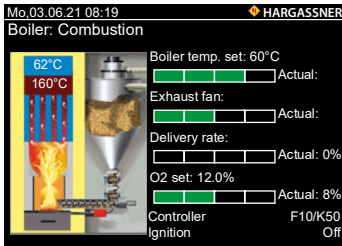

Info page about the current set / actual values of the boiler

- Current operating status of the boiler
- Water temperature in the boiler
- Exhaust fan speed in % of maximum speed
- Currently necessary fuel rate
- Flue gas oxygen value in % - measured on the lambda sensor
- Current temperature in the combustion chamber (flue gas temperature)
- Firebed sensor position (tongue)
- Ignition active / not active

## 6.7 Accumulator

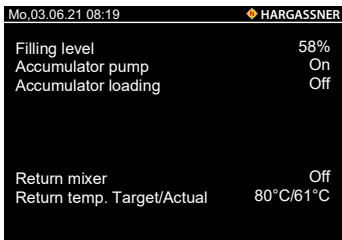

Info page about the current actual values of the accumulator

- Accumulator fill level display
- ☞ Filling level: 80% = red
- ☞ Filling level: 30% = blue
- ☞ Fill level between 30% and 80% = blue / red
- Return temperature Target / Actual = Temperature of boiler return

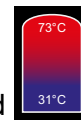

- **One-time charge** button 
- ☞ Press the button to recharge the HWT once to its target temperature

## 6.8 External heat

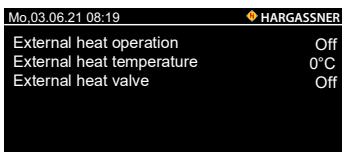

Info page about the current values of the external heat

- External heat operation indicator (**On / Off**)
- Current external heat sensor temperature
- External heat valve indicator (**On / Off**)

## 6.9 Consumption



Info page about the current overall consumption

- Only displayed if the pellet consumption display is activated in the commissioning engineer settings

## 6.10 Trend

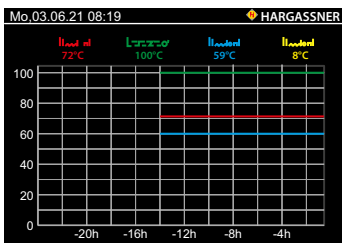

Diagram of recording from the last 24 hours

- Boiler temperature
- HWT temperature
- Power
- Accumulator filling level
- ☞ The timeline can be set for activated service settings

## 6.11 Meter

Mo.03.06.21 08:19		HARGASSNER
Control unit operating hours	9h	
Heating operating hours	9h	
Ignition operating hours	0.0h	
Exhaust fan operating hours	9h	
Stoker operating hours	7.34h	
Extraction operating hours	5.8h	
Vacuum turbine operating hours	0	
Vacuum turbine switching cycles	0	

List of current operating hours

Mo.03.06.21 08:19		HARGASSNER
Runtime of CMB since de-ash	180 min.	
De-ash at the earliest after	60 min.	
De-ash at the latest after	180 min.	
ST runtime since pellet filling	0 min.	
Pellet filling no earlier than	30 min.	
Pellet filling no later than	300 min.	
No. De-ash cycles	0	
Cleaning for number of de-ash cycles	1	
Number of SLG movements	0	

## 6.12 Serial number

Mo.03.06.21 08:19		HARGASSNER
Boiler type	Nano-PK	
Commission no.	000000	
Software version	V14.0I	
Control unit serial number	575142	
Firmware version I / O		
Serial number I / O		
IP address	0.0.0.0	
Boiler status ID-Card	OK	
System code	3035B7B0	
SW update	02.04.2019 11:26	

List of the relevant system data

## 6.13 Error

Mo.03.06.21 08:19		HARGASSNER
0305	Wrong boiler ID-Card Mon 19-11-2018 09:19	
0307	Exhaust fan error Mon 19-11-2018 09:19	

Overview of current errors

☞ Once the fault is rectified, the error message is no longer shown

## 7 Manual operation



### WARNING

#### Risk of injury due to unexpected operating conditions

- Limit switches or motors are not monitored in manual operation
  - ☞ Reverse operation of augers permissible for max. 2 [sec.]
- Allow trained staff only to manually operate the system



**Manual mode** is used to:

- Check all electrical functions
- Manually operate or check the drives after a malfunction

- To activate the function, press or press and hold the button
- To deactivate the function, press again or release the button
- ☞ To activate continuous operation (max. 2 minutes), double-click the button when the service settings are activated

Only the selected function is activated. All other functions are inactive.

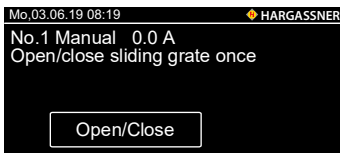

No. 1 Function check of the sliding grate

- Pressing the button opens and closes the sliding grate once
- ☞ Generated ash drops into the ash pan
- ☞ Press the button every time the boiler was cleaned



No. 2 Function check of the sliding grate

- Pressing the button either opens or closes the sliding grate once

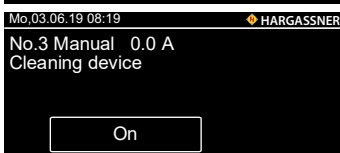

No. 3 Function check of the cleaning device

- ☞ Grate opens completely and cleaning motor starts running
- ☞ Press the button again to end the function check. The cleaning motor will move to its final position and the grate will close

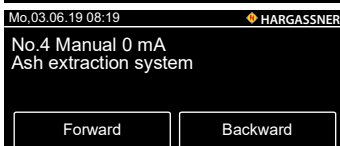

No. 4 Function and rotation check of ash extraction motor

- Manual forward or backward of the motor
- ☞ Press Backward button only **briefly**



No. 5 Function and rotation check of stoker auger motor

- Manual forward and backward to fill the stoker auger
- ☞ Press Backward button only **briefly**
- ☞ Fill stoker auger

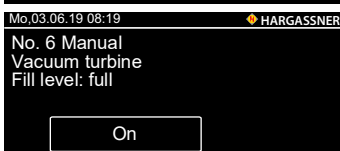

No. 6 Function check of the pellet vacuum turbine

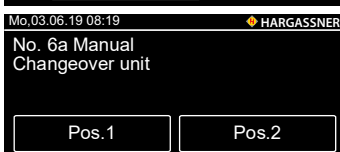

No. 6a Function check of the changeover unit

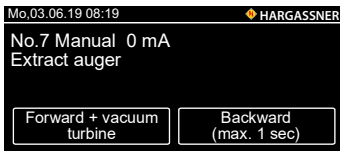

No. 7 Function and rotation check of storage room extraction motor

- Manual forward and backward of the motor to clear any blockages
- ☞ Manual flow also starts the vacuum turbine
- ☞ Only press the Return button **briefly** (maximum 1 second)

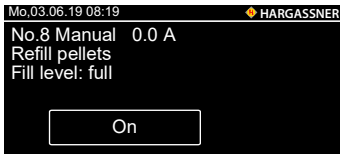

No. 8 Filling the day hopper

- ☞ Must be filled at restart
- ☞ The fill level indicator switches the turbine off automatically

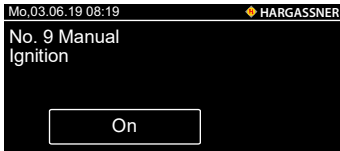

No. 9 Function check of ignition

- ☞ After a maximum of 1 minute, the coil should be hot
- ☞ After 3 minutes the ignition coil switches off

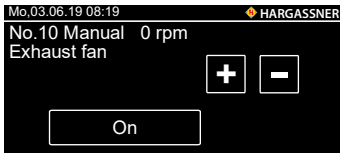

No. 10 Function check of the exhaust fan motor

- ☞ Maximum speed approx. 2600 rpm



No. 11 Function check or manual operation of HWT loading pump A

- ☞ Only possible when heat circuit board **HC A** is connected

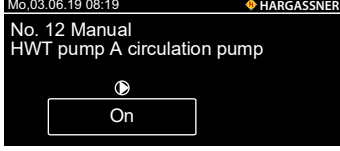

No. 12 Function check or manual operation of circulation pump HWT A

- ☞ Only possible when heat circuit board **HC A** is connected

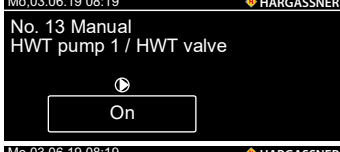

No. 13 Function check or manual operation of HWT loading pump 1

- ☞ Nos. 15 and 17 for HWT pumps 2 and 3 only possible when **HKM 1** and **HKM 2** are connected
- ☞ No. 18b for HWT pump B

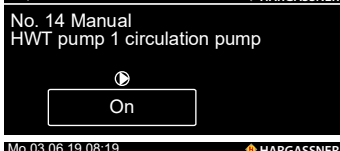

No. 14 Function check or manual operation of circulation pump HWT 1

- ☞ Nos. 16 and 18 for circulation pumps HWT 2 and 3 only possible when **HKM 1** and **HKM 2** are connected
- ☞ No. 18c for circulation pump HWT B

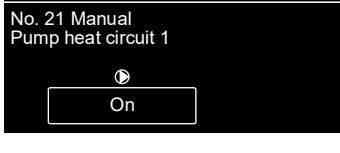

Function check or manual operation of heat circuit pumps

No. 19 for heat circuit pump A (**HC A**)

Nos. 21 and 23 for heat circuit pumps 1 and 2 (**boiler**)

Nos. 25, 27 and 29 for heat circuit pumps 3 and 4 and external heat circuit pump 2 (**HKM 1**)

Nos. 30, 32 and 34 for heat circuit pumps 5 and 6 and external heat circuit pump 3 (**HKM 2**)

No. 34b for heat circuit pump B



Function and rotation direction check of heat circuit mixer

No. 20 for heat circuit mixer A (**HC A**)

Nos. 22 and 24 for heat circuit mixers 1 and 2 (**boiler**)

Nos. 26 and 28 for heat circuit mixers 3 and 4 (**HKM 1**)

Nos. 31 and 33 for heat circuit mixers 5 and 6 (**HKM 2**)

No. 34c for heat circuit mixer B

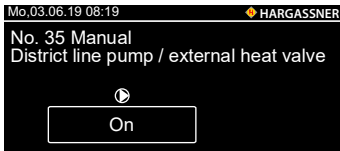

No. 35 Function check or manual operation of district line pump or booster pump

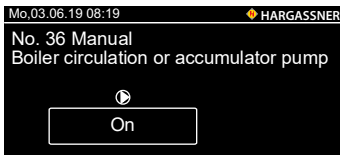

No. 36 Function check or manual operation of the parametrised pump

- Boiler circulation pump
- Accumulator pump

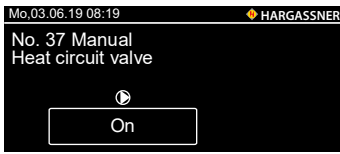

No. 37 Function and rotation check of the heat circuit valve

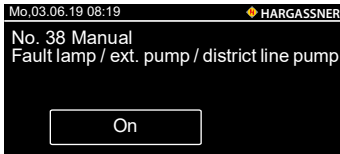

No. 38 Function check or manual operation of the fault lamp, external pump or district line pump

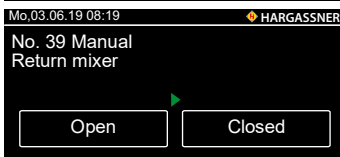

No. 39 Function check or short-term manual operation of the return mixer

- ☞ The mixer is **Closed** when the boiler circuit is closed, and the mixer is **Open** when the return is open
- ☞ During operation, the return temperature increases when the mixer is **Closes** and the return temperature decreases when the mixer **Opens**

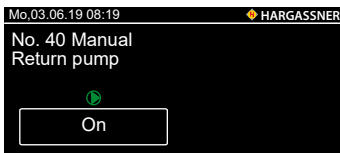

No. 40 Function check or short-term manual operation of the return pump

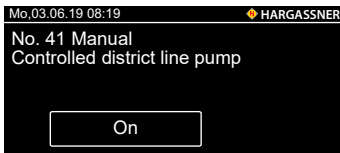

No. 41 Function check or manual operation of the pump for the controlled district line

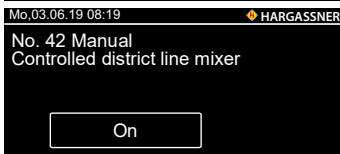

No. 42 Function and rotation check of the mixer for the controlled district line

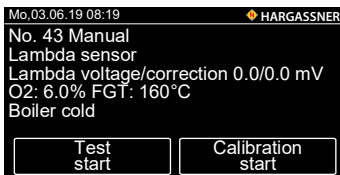

No. 43 Test lambda sensor

- Function check only possible at a flue gas temperature (FGT) below 50°C
- Press **Test start**
- ☞ After 5 minutes, the voltage of the sensor should be around -7.0 [mV]
- ☞ Values between -2 and -12 mV are within the tolerance range

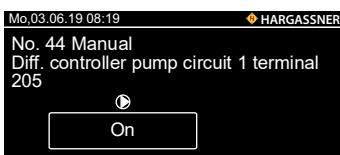

No. 44 Function check or manual operation of the differential controller pump circuit 1 terminal 205

- ☞ Only when a differential controller is connected

No. 44b Differential controller pump heat source Tno. 202

No. 44c Differential controller valve / return mixer

No. 45 Function check or manual operation of the differential controller pump 2 circuit 1 terminal 205

No. 45c Differential controller 2 valve / return mixer

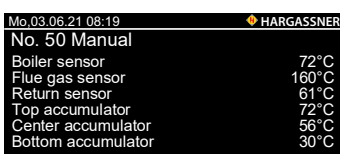

No. 50 - 54 Display of the current sensor values

- ☞ According to parametrised heating system

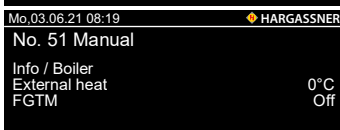



Mo,03.06.21 08:19 HARGASSNER  
No. 52 Manual  
HWT sensor 1 57°C  
HC1 sensor 40°C  
HC2 sensor 40°C  
Remote control 1 20.0°C

Mo,03.06.21 08:19 HARGASSNER  
No. 53 Manual  
HWT sensor 2 57C  
HC3 sensor 40°C  
HC4 sensor 40°C  
Remote control 3 0°C  
Remote control 4 0°C

Mo,03.06.19 08:19 HARGASSNER  
No. 59 Manual  
Last maintenance on ...  
Heating hours: 0.0 h  
Full-load hours: 0.0 h  
Exhaust fan: 0.2 h  
Consumption: 0.00 t  
Reset maintenance  
Reset vacuum turbine counter

No. 59 Reset maintenance

## 8 Settings menu

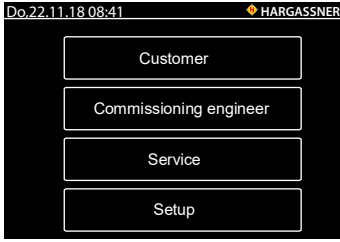

Press the **Set** button in the standard display to access the Settings menu.

- Customer
- Commissioning engineer
- Service
- Setup

### 8.1 Customer

This button will take you to the configuration screens, which can also be accessed from the standard menu.

⇒ See "Customer settings" on page 34.

### 8.2 Commissioning engineer

Permits advanced system settings and is only available to commissioning engineer and Hargassner service personnel. The individual parameter settings depend on the respective heating system configuration.

Code: 33

⇒ See "Commissioning settings" on page 40.

### 8.3 Service

Allows more parameter details to be changed and is only available to service personnel. The individual parameter settings depend on the respective heating system configuration.

**Note:** Commissioning engineer and service settings are protected by a PIN code. Only service personnel can change them, as the parameters may impair the functionality of the heating system if poorly selected.

### 8.4 Setup

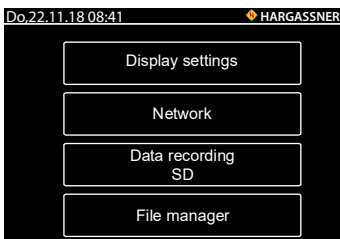

The following setting options are available:

- Display settings
- Network settings
- Data recording (SD)
- File manager

#### 8.4.1 Display settings

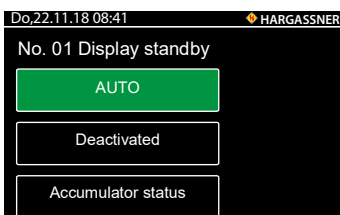

No. 01 Display standby

☞ Activates or deactivates standby mode

☞ Accumulator status shows the current accumulator loading in standby mode

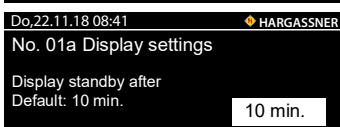

No. 01a Display settings

☞ Display switches to standby mode after preset time

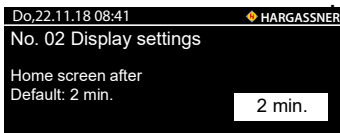

#### No. 02 Display settings

- ☞ Display switches to Home view after a set time
- ☞ Setting 0 deactivates this function

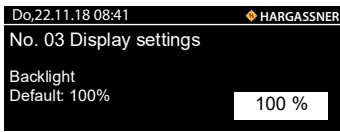

#### No. 03 Display settings

- ☞ Set display backlight (10% - 100%)

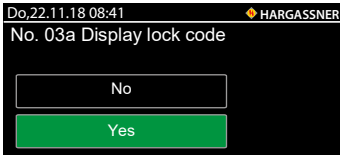

#### No. 03a Display lock code

- ☞ Select whether you want to enter a code to lock the display

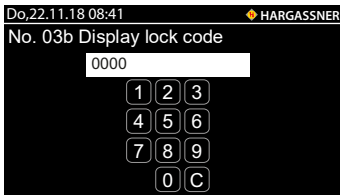

#### No. 03b Display lock code

- ☞ Enter 4-digit lock code

### 8.4.2 Network settings

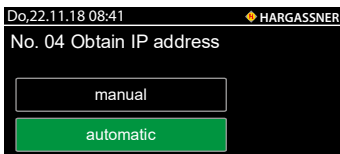

#### No. 04 Obtain IP address

- ☞ Select whether you want to generate the IP address manually or automatically

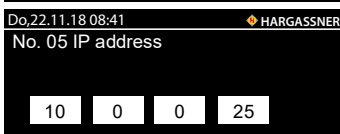

#### No. 05 IP address

- ☞ Manual entry of the IP address

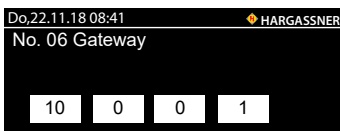

#### No. 06 Gateway

- ☞ Manual entry of the gateway

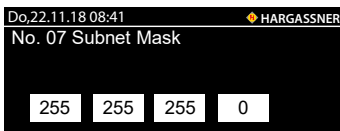

#### No. 07 Subnet Mask

- ☞ Manual entry of the Subnet Mask

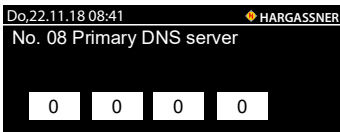

#### No. 08 Primary DNS server

- ☞ Manual entry of the Primary DNS server

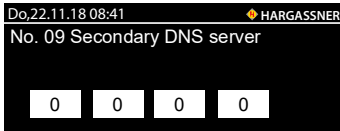

#### No. 09 Secondary DNS server

- ☞ Manual entry of the secondary DNS server

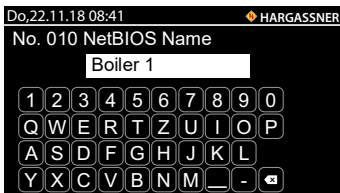

#### No. 010 Display of the name of device

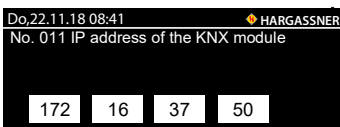

#### No. 011 IP address of the KNX module



---

#### 8.4.3 Data recording (SD)

Additional saving of current boiler data on the SD card.

To finish the protocol, press **Stop SD logging**

#### 8.4.4 File manager

Used to import and export parameter information, text files, languages, backups and error lists.

## 9 Customer settings

- In the standard menu, press the **Set** button and then press the **Customer** button
- Select the desired setting value with the arrow button
- Select the values by touching the fields highlighted in white
  - ☞ The font colour of the parameters changes to **red**
- Press the **+** and **-** buttons to set your desired values - the display flashes
  - ☞ Press and hold the **+** and **-** buttons for to adjust the values quickly
- Confirm the set value with the green checkmark

### 9.1 HWT control

- ☞ The day clock is set to weekly clock and the number of blocks is changed in the commissioning engineer settings (parameter D9 + D10)

#### 9.1.1 Day timer

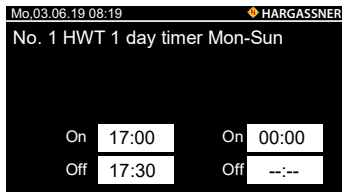

No. 1 HWT 1 day timer Mon-Sun

- Setting the loading times of the HWT using the day timer

#### 9.1.2 Week timer

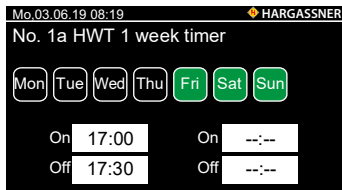

No. 1a HWT 1 week timer

- Setting the loading times of the boiler using the week timer
- ☞ Selected day = green

#### 9.1.3 Target temperature

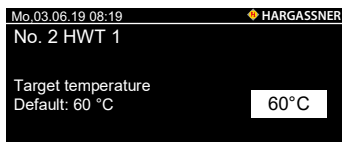

No. 2 HWT 1 - Setting the HWT target temperature

- ☞ HWT loading is done only during the set **loading times**

#### 9.1.4 Circulation pump

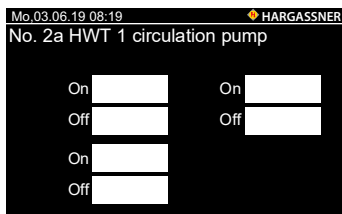

No. 2a HWT 1 circulation pump

- Setting the switching times of the circulation pump (if available)

### HWT temperatures according to factory settings

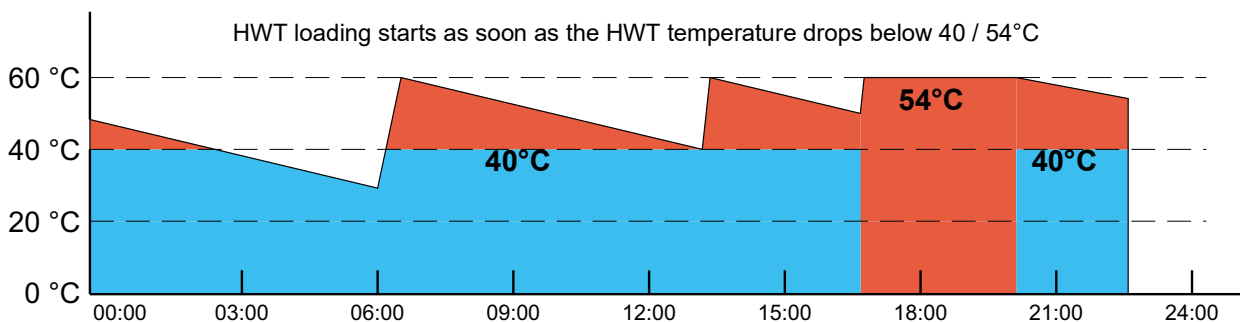

## 9.2 Control of heat circuits

- ☞ The day clock is set to weekly clock and the number of blocks is changed in the commissioning engineer settings (commissioning engineer parameters D9 + D10)

### 9.2.1 Day timer

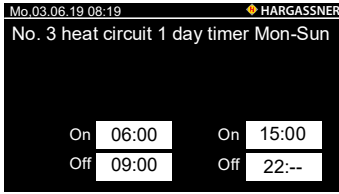

No. 3 heat circuit 1 day timer Mon-Sun

- Setting the heating times using timer
- ☞ The selected times are the same for all weekdays

### 9.2.2 Week timer

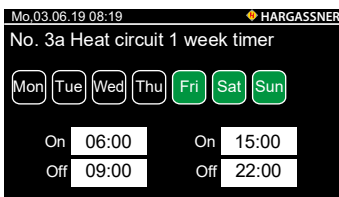

No. 3a Heat circuit 1 week timer

- Setting the heating times using the week timer

### 9.2.3 Room temperature

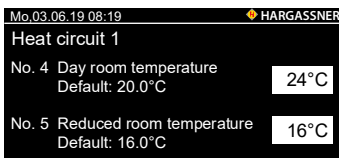

No. 4 Day room temperature / No. 5 Reduced room temperature

- Set the desired room temperature
- ☞ Range of the day room temp.: 14°C - 26°C
- ☞ Range of the setback/reduced room temperature: 8°C - 24°C

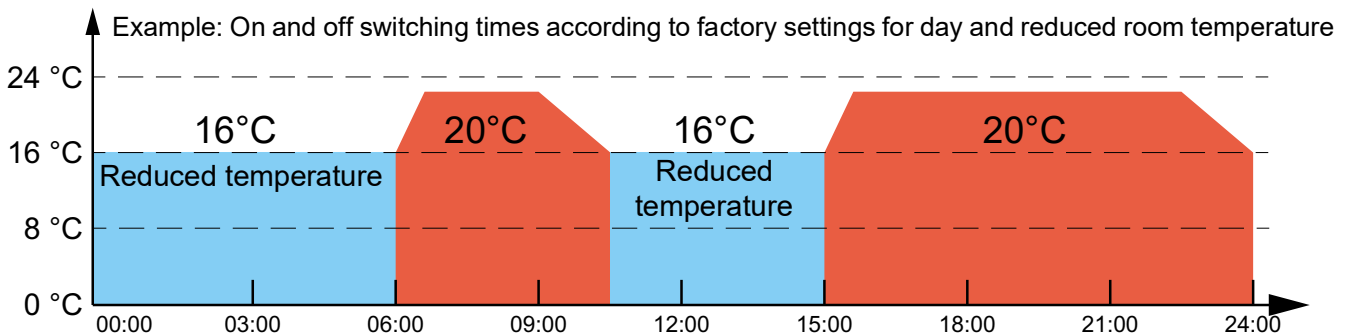

### 9.2.4 Outside temperature shut-down

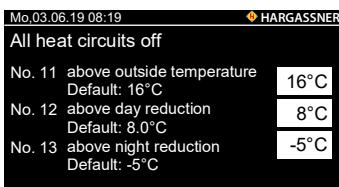

- Setting the temperatures for the outside temperature shut-down

☞ 3 possible thresholds depending on the heating programme and time

#### No. 11 All heat circuits off via outside temperature

- ☞ If the average outside temperature exceeds the set value, the heat circuits will be switched off (summer shut-down)

#### No. 12 All heat circuits off during day reduction

- ☞ If the average outside temperature exceeds the set value in day reduction mode, the heat circuits will be switched off

#### No. 13 All heat circuits off during night reduction

- ☞ If the average outside temperature exceeds the set value during the night reduction time, the heat circuits will be switched off

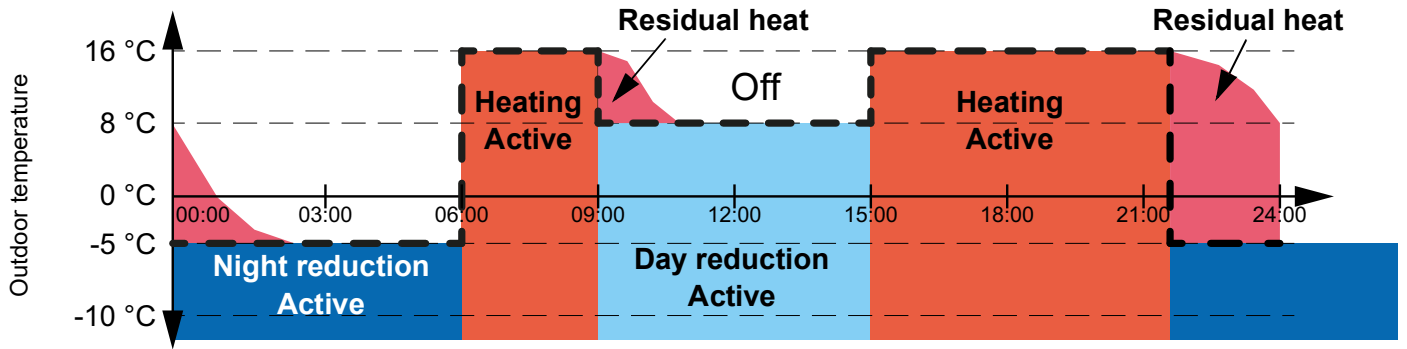

### 9.3 Pellet filling times

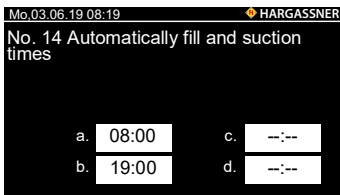

- No. 14 Filling pellets
- Setting the pellet filling times in the day hopper

### 9.4 General settings

#### 9.4.1 Holiday mode

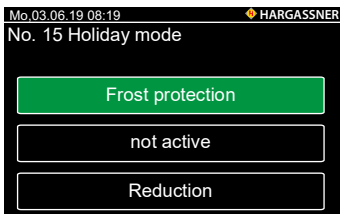

- No. 15 Holiday mode
- Setting the holiday mode function



- No. 16 Holiday time
- Setting the holiday time during which holiday mode is activated

#### 9.4.2 Starting de-ash

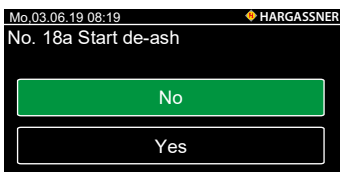

- No. 18a Start de-ash
- ☞ Only activated if parameter D50 is set to **Available** in the commissioning engineer settings
  - Press the **Yes** button to start the de-ash and cleaning process

#### 9.4.3 Date/time

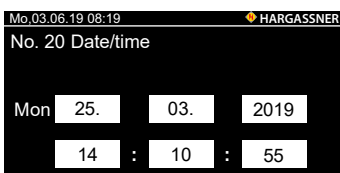

- No. 20 Date/time
- Setting the date and time

## 9.4.4 Firing off

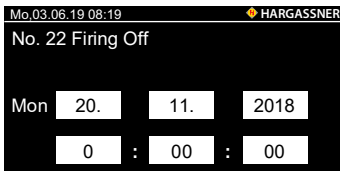

### No. 22 Firing Off

- Setting the date and time for when firing is switched off (e.g. when the chimney sweep is expected)

## 9.4.5 Consumption display

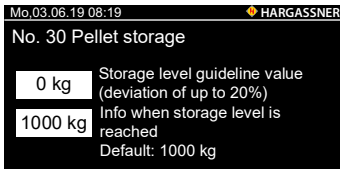

### No. 30 Pellet storage

- ☞ Only activated if parameter D1f is set to **Available** in the commissioning engineer settings
- ☞ Deviations of up to 20% possible

## 9.4.6 Fresh-water station

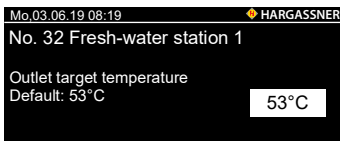

### No. 32 Fresh-water station

- Setting the maximum temperature of the hot water at the tapping point
- ☞ Only activated if parameter B100 is set to **Available** in the commissioning engineer settings

# 9.5 Parameter list of customer settings

## 9.5.1 Standard heat circuits on the boiler board

Menu	Description	Default
1	HWT 1 day timer Mo-Su	On 17:00 Off 17:30
1a-g	HWT 1 weekly Mo/Tu/We/Th/Fr/Sa/Su	On 17:00 Off 17:30
2	HWT 1 set temperature	60 °C
2a	Circulation pump HWT 1	On 06:00 11:00 16:00 Off 08:00 13:00 20:00
3	Heat circuit 1 day timer Mo-Su	On 06:00 15:00 Off 09:00 22:00
3a-g	Heat circuit 1 week timer Mo/Tu/We/Th/Fr/Sa/Su	On 06:00 15:00 Off 09:00 22:00
4	Heat circuit 1 day room temperature	20 °C
5	Heat circuit 1 reduced room temperature	16 °C
6	Heat circuit 2 day timer Mo-Su	On 06:00 15:00 Off 09:00 22:00
6a-g	Heat circuit 2 week timer Mo/Tu/We/Th/Fr/Sa/Su	On 06:00 15:00 Off 09:00 22:00
7	Heat circuit 2 day room temperature	20 °C
8	Heat circuit 2 reduced room temperature	16 °C

## 9.5.2 Heat circuit board HC A

Menu	Description	Default
HP1	HWT A day timer Mo-Su	On 17:00 Off 17:30
HP 1a-g	HWT A week timer Mo/Tu/We/Th/Fr/Sa/Su	On 17:00 Off 17:30
HP 2	HWT A set temperature	60 °C
HP 2a	HWT A circulation pump	On 06:00 11:00 Off 08:00 13:00
HP 3	Heat circuit A day timer Mo-Su	On 06:00 15:00 Off 09:00 22:00

Menu	Description	Default
HP 3a-g	Heat circuit A week timer Mo/Tu/We/Th/Fr/Sa/Su	On 06:00 15:00 Off 09:00 22:00
HP 4	Heat circuit A day room temperature	20 °C
HP 5	Heat circuit A reduced room temperature	16 °C

### 9.5.3 Extension module HKM 1

Menu	Description	Default
H 1	HWT 2 day timer Mo-Su	On 17:00 Off 17:30
H 1a-g	HWT 2 weekly Mo/Tu/We/Th/Fr/Sa/Su	On 17:00 Off 17:30
H 2	HWT 2 set temperature	60 °C
H 2a	HWT 2 circulation pump	On 06:00 11:00 Off 08:00 13:00
H 3	Heat circuit 3 day timer Mo-Su	On 06:00 15:00 Off 09:00 22:00
H 3a-g	Heat circuit 3 week timer Mo/Tu/We/Th/Fr/Sa/Su	On 17:00 Off 20:00
H 4	Heat circuit 3 day room temperature	20 °C
H 5	Heat circuit 3 reduced room temperature	16 °C
H 6	Heat circuit 4 day timer Mo-Su	On 06:00 15:00 Off 22:00 09:00
H 6a-g	Heat circuit 4 week timer Mo/Tu/We/Th/Fr/Sa/Su	On 17:00 Off 20:00
H 7	Heat circuit 4 day room temperature	20 °C
H 8	Heat circuit 4 reduced room temperature	16 °C

### 9.5.4 Extension module HKM 2

Menu	Description	Default
H 11	HWT 3 day timer Mo-Su	On 17:00 Off 17:30
H 11a-g	HWT 3 weekly Mo/Tu/We/Th/Fr/Sa/Su	On 17:00 Off 17:30
H 12	HWT 3 set temperature	60 °C
H 12a	HWT 3 circulation pump	On 06:00 11:00 Off 08:00 13:00
H13	Heat circuit 5 day timer Mo-Su	On 06:00 15:00 Off 09:00 22:00
H 13a-g	Heat circuit 5 week timer Mo/Tu/We/Th/Fr/Sa/Su	On 17:00 Off 20:00
H 14	Heat circuit 5 day room temperature	20 °C
H 15	Heat circuit 5 reduced room temperature	16 °C
H 16	Heat circuit 6 day timer Mo-Su	On 06:00 15:00 Off 09:00 22:00
H 16a-g	Heat circuit 6 week timer Mo/Tu/We/Th/Fr/Sa/Su	On 06:00 15:00 Off 22:00 09:00
H 17	Heat circuit 6 day room temperature	20 °C
H 18	Heat circuit 6 reduced room temperature	16 °C

### 9.5.5 Heat circuit board HC B

Menu	Description	Default
H21	HWT B day timer Mo-Su	On 17:00 Off 17:30
H21 a-g	HWT B week timer Mo/Tu/We/Th/Fr/Sa/Su	On 17:00 Off 17:30
H22	HWT B target temperature	60 °C
H22a	Circulation pump HWT B	On 06:00 11:00 Off 08:00 13:00
H23	Heat circuit B day timer Mo-Su	On 06:00 15:00 Off 09:00 22:00
H23a-g	Heat circuit B week timer Mo/Tu/We/Th/Fr/Sa/Su	On 06:00 15:00 Off 09:00 22:00
H24	Heat circuit B day room temperature	20 °C
H25	Heat circuit B reduced room temperature	16 °C



Different temperatures can be set for each heating circuit by parameterising outdoor temperature shut-off separately (parameter no. D12)

Menu	Description	Default
No. 11	Heating off at outside temperature over	16 °C
No. 11a-i	Heat circuit 1-B and ext. HC off above outside temperature	16 °C
No. 12	All heat circuits off during day reduction	8 °C
No. 12a-h	Heat circuit 1-B off during day reduction	8 °C
No. 13	All heat circuits off during night reduction	-5 °C
No. 13a-h	Heat circuit 1-B off during night reduction	-5 °C
No. 14	Automatically fill and suction times	On 08:00 00:00 Off 19:00 00:00
No. 14a	Automatically fill and suction times	On 07:00 14:00 Off 19:00 00:00
No. 14b	Automatically fill and suction times	On 21:00 00:00 Off 00:00 00:00
No. 15	Holiday mode	not active
No. 15a-h	Holiday mode heat circuit 1-B	not active
No. 16	Holiday time for all heat circuits	from...
No. 17	Holiday time for all heat circuits	until...
No. 16a-h	Heat circuit 1-B holiday time	from...
No. 17a-h	Heat circuit 1-B holiday time	until...
No. 18a	De-ash start	No
No. 20	Date/time	
No. 21	Release of remote maintenance	not released
No. 21a	Automatically deactivate remote maintenance release	1 h
No. 22	Firing off	from... - until...
No. 30	Pellet storage (info when storage level is reached)	1000 kg

## 10 Commissioning settings

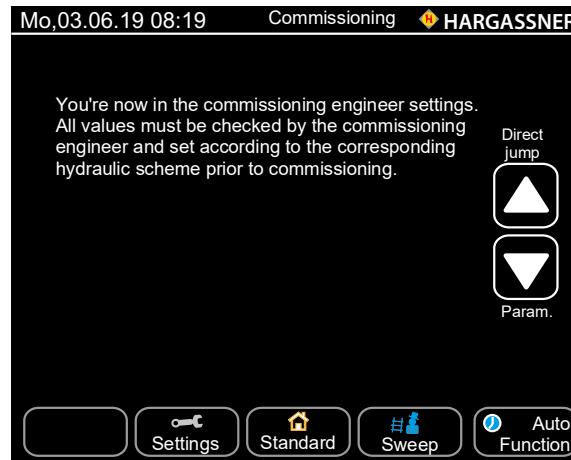
- In the Standard menu, press the **Settings** and **Commissioning engineer** buttons
- Release by entering the code: 33



- Use the arrow key to select the desired setting values
  - ☞  Takes you straight to the parameter groups
  - ☞  Selects all parameters
- Select the values by touching the fields highlighted in white
  - ☞ The font colour of the parameters changes to red
- Press the + and - buttons to set your desired values - the display flashes
  - ☞ Press and hold the + and - buttons for to adjust the values quickly
- Confirm the set value with the green checkmark

### 10.1 Parametrising the heat circuits and HWT

#### Standard parameters (on the boiler board):

- Heat circuit 1 (No. A1 - No. A10)
- Heat circuit 2 (No. A11 - No. A20)
- HWT 1 (No. B1 - No. B9b)

#### Extension module 1 (HKM 1):

- Heat circuit 3 (No. A21 - No. A30)
- Heat circuit 4 (No. A31 - No. A40)
- HWT 2 (No. B11 - No. B19b)

#### Extension module 2 (HKM 2):

- Heat circuit 5 (No. A41 - No. A50)
- Heat circuit 6 (No. A51 - No. A60)
- HWT 3 (No. B21 - No. B29b)

#### Heat circuit board (HC A)

- Heat circuit A (No. A61 - No. A70)
- HWT A (No. B31 - No. B39b)

#### Heat circuit board (HC B)

- Heat circuit B (No. A71 - No. A80)
- HWT B (No. B41 - No. B49b)

- ☞ The parameters of the heat circuits, HWTs, extension modules and the heat circuit board are only displayed when hardware is connected

## 10.2 Parameter A - heat circuits

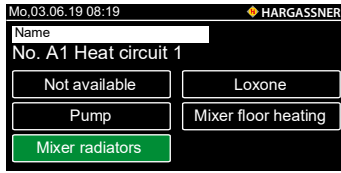

No. A1 Heat circuit **1** and **2** when using the extension module **0**  
5 options:

- Heat circuit not available
  - Heat circuit with pump
  - Heat circuit with pump and mixer motor for radiator heat circuit
  - Heat circuit control by Loxone
  - Heat circuit with pump and mixer motor for floor heat circuits
- ☞ If No. A1 is set to **not available**, then No. A2 to No. A6 are not displayed  
 Press **Name** to name each heat circuit separately

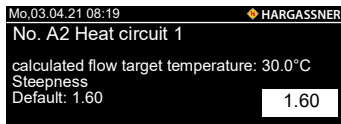

No. A2 Steepness

Describes the relationship between flow and outside temperatures (see heating curve)

- Range: 0.2 - 3.5
  - Recommended settings:
    - Floor heating: 0.3 - 1.0
    - Radiator heating: 1.2 - 2.0
    - Convector heating: 1.5 - 2.0
- ☞ Change in small steps only and for a longer period

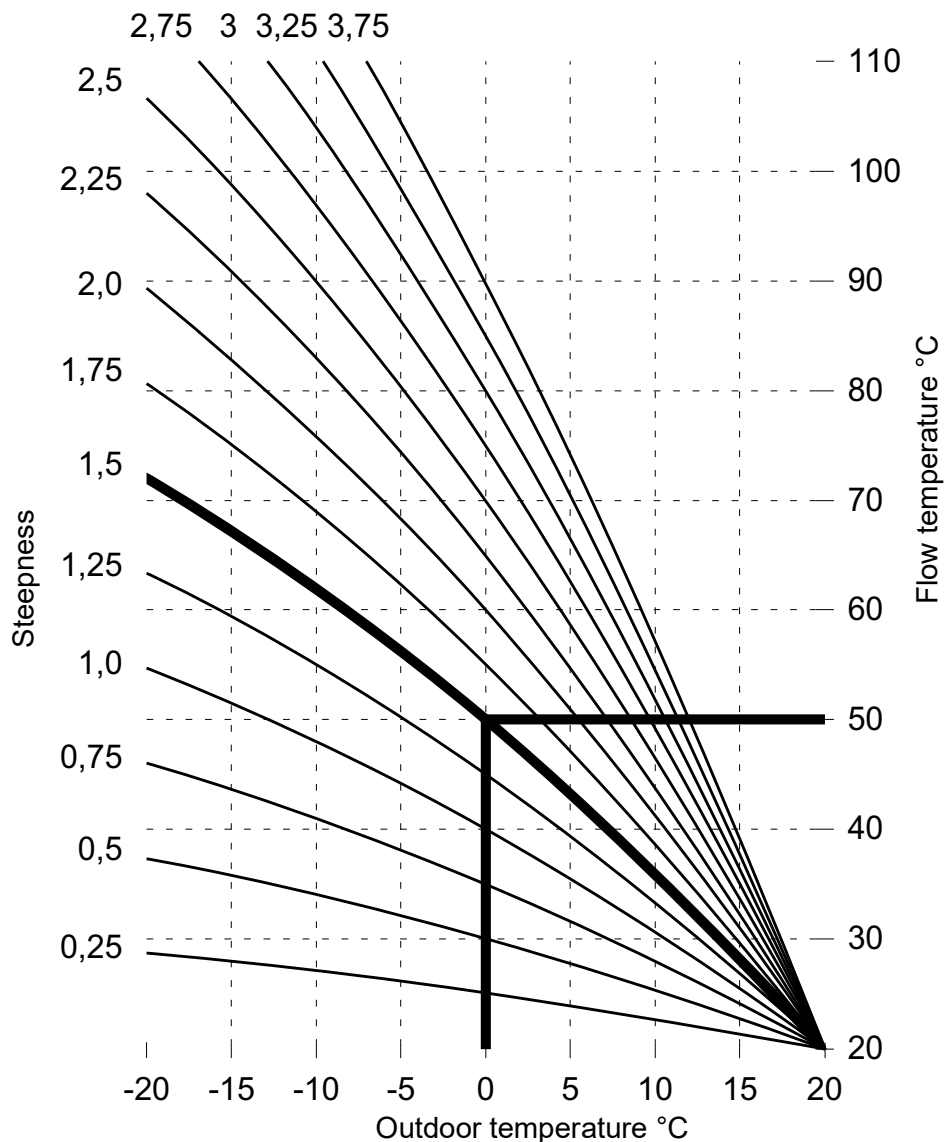

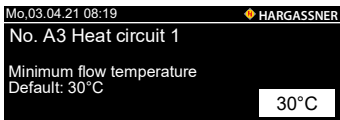

No. A3 Minimum limit for heat circuit 1 flow temperature  
 ☞ This flow temperature won't be underrun in heating or reduction mode  
 ☞ Range: 1 - 80 °C

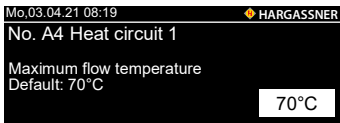

No. A4 Maximum limit for heat circuit 1 flow temperature  
 ☞ This flow temperature won't be overrun in heating or reduction mode  
 ☞ **Floor heating:** Integrate an additional electromechanical thermostat which interrupts the power supply to the relevant heat circuit pump

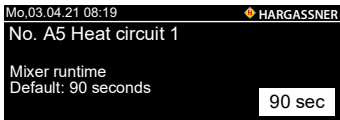

No. A5 Numerical input of the actual mixer runtime (see type plate)  
 ☞ Duration from closed to open condition  
 ☞ Range: 10 - 300 Sec.

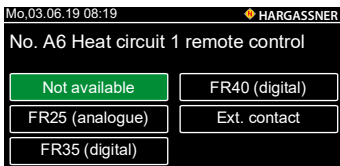

No. A6 Heat circuit 1 and 2 remote control, 5 setting options:

- Not available
- Heat circuit with analogue remote control FR25
- Heat circuit with digital remote control FR35
- Heat circuit with digital remote control FR40
- External switch contact on terminals **54** and **55** or terminals **56** and **57**

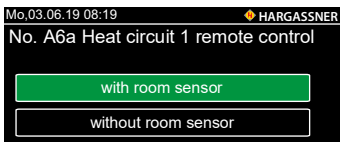

No. A6a / b / c The remote control may be installed with or without a room sensor

- Heat circuit with analogue remote control **FR25 without room sensor**
  - No automatic adjustment of the room temperature
  - Wire FR25 at **terminals 1 and 3**
- Heat circuit with analogue remote control **FR25 without room sensor**
  - Automatic adjustment of the room temperature
  - Wire FR25 at **terminals 1 and 2**
- Heat circuit with digital remote control **FR35** or **FR40**
  - If **FR35** is set, parameter **A6b** appears
  - If **FR40** is set, parameter **A6c** appears

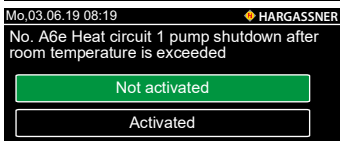
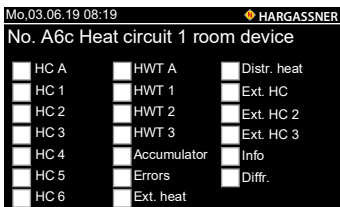
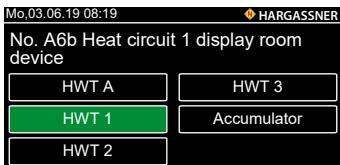

No. A6e Pump switches off after room temperature is exceeded

- **Not activated:** Standard heat circuit control
- **Activated:** If the room temperature (set temperature) is exceeded by the set value (No. M6 service parameter), the heat circuit pump switches **Off** and the mixer is **Closed**
  - ☞ The pump and mixer will come **On** again when the room temperature drops below the set room temperature by the preset value (service parameter M6a)

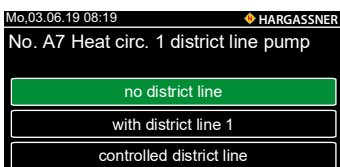

No. A7 Activate district line pump when heat circuit pump 1 is running

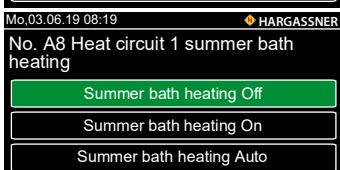

No. A8 Activation of summer heating function of the corresponding heat circuit  
 ☞ Heat circuit will be switched on (depending on timer settings) if accumulator is on temperature  
 ☞ Is only activated in menu **HWT**  
 ☞ When **On** is selected, **A8a - A8c** customer parameters appear

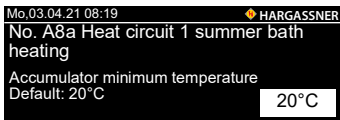

No. A8a Enter the accumulator minimum temperature

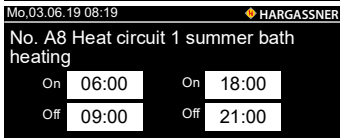

No. A8b Enter the switch-on and switch-off times

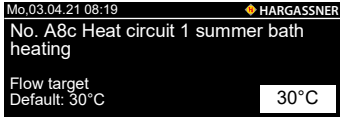

No. A8c Enter flow target temperature

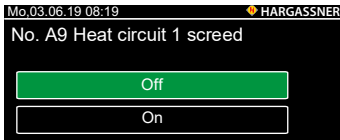

No. A9 Activation of screed heating function of the corresponding heat circuit  
 ☞ When **On** is selected, customer parameters **A100 - A103** appear  
 • Pressing the Heating curve button will take you straight to parameter **A100**

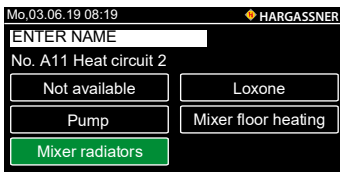

A11: Second additional heat circuit on the control unit  
 A21, A31: When using an extension module 1  
 A41, A51: When using an extension module 2  
 A61: When using a heat circuit board **A**  
 A71: When using a heat circuit board **B**  
 ☞ Setting options: See heat circuit 1 (**A1 - A9**)

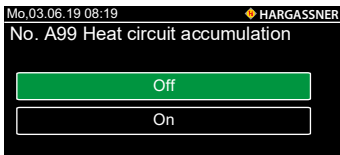

A99 Heat circuit accumulation  
 If this function is activated, the boiler will temporarily increase the heat circuit's flow temperature instead of switching to slumber mode. A greater heat consumption is generated as a result, which enables the boiler to stay on full load longer if an accumulator is not available.

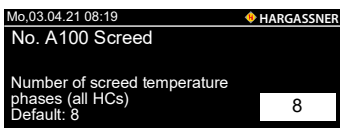

No. A100 Screed temperature phases  
 Specifies the number of phases used to increase the temperature for the screed heating process.

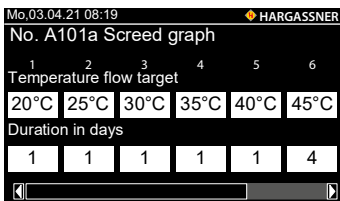

No. A101a Screed graph  
 The target temperature and holding period can be specified for each phase.

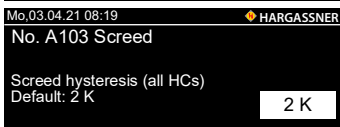

No. A103 Screed hysteresis  
 ☞ If the flow temperature drops below the screed heating target temperature by this value, the timer for the holding period will be stopped and won't resume until the target value has been reached again

### 10.3 Parameter B - HWT

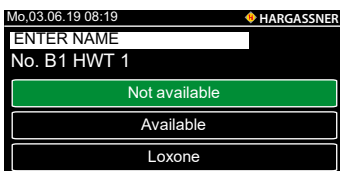

No. 1 HWT  
 • No. B1 HWT 1 setting on **Available**  
 ☞ Control of HWT 1  
 • HWT 1 setting on **Loxone**  
 ☞ Control of HWT 1 by the Loxone control unit  
 • Parameter No. B1 on **Not available**  
 ☞ If No. B1 is set to **Not available**, Nos. B2 to B6 are not displayed  
 Press on **Name** to name each HWT separately

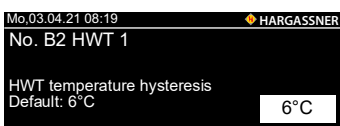

No. B2 HWT 1 hysteresis  
 ☞ Value at which the HWT is switched on below the set minimum temperature  
 ☞ Range: 1 - 40 °C

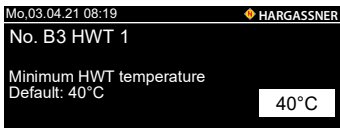

No. B3 Lower HWT limit temperature

- ☞ If the HWT temperature drops below the preset value, HWT loading starts within the set time (installer parameter no. B90) and independent of the HWT time programme (customer parameter no. 1)
  - Range: 1 - 80 °C

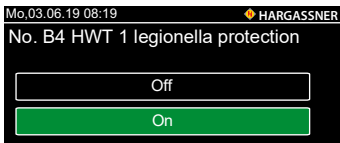

No. B4 Activate the Legionella protection programme

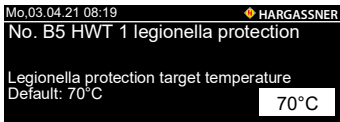

No. B5 HWT target temperature for legionella protection

- ☞ Temperatures of 70°C or above for more than 3 minutes will kill all legionella in the HWT

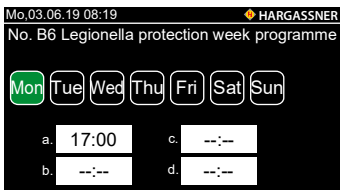

No. B6 Legionella protection week programme

- ☞ Green = active
- ☞ Start legionella protection programme during HWT loading only

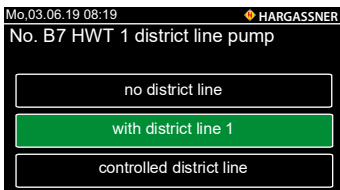

No. B7 HWT 1 district line pump

- ☞ Activate district line pump when HWT pump 1 is running

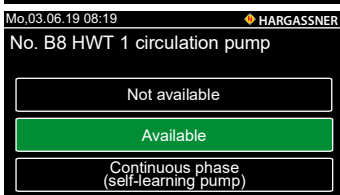

No. B8 HWT 1 circulation pump

- ☞ The circulation pump can be set for each HWT parametrised on the controller

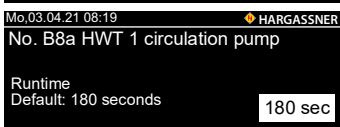

No. B8a Runtime circulation pump HWT

- ☞ The runtime depends on the length of the heating pipes and on the heat loss (insulation) in the line

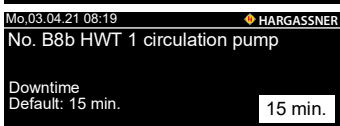

No. B8b Downtime circulation pump HWT

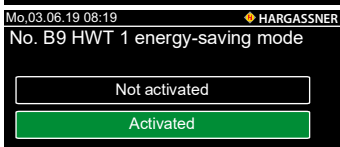

No. B9 Energy-saving mode

- **Not activated:** The HWT is loaded in accordance with the settings in the customer parameters
- **Activated:** The HWT is loaded regardless of the loading times if the following criteria are met for the set length of time (**No. B9a**) before setback/reduction
  - HWT has nearly reached its minimum temperature
  - Outside temperature is higher than the temperature for day reduction
  - Boiler is in lower partial-load operation (minimum output + 10%)

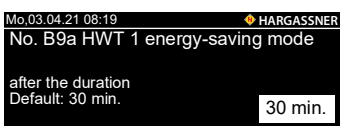

No. B9a Switch-on time of energy-saving mode

- ☞ The HWT is loaded when the following criteria have been met for 30 minutes **before** reduction
  - Outside temperature above 16 °C (customer parameter no. 5)
  - HWT temperature below 50 °C (commissioning engineer parameter No. B3 (40°C) + 10°C)
  - Boiler output below 60% (service parameter no. K1 (50%) + 10%)

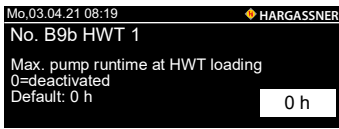

No. B9b Maximum pump runtime when HWT loading  
 ☞ Default: 0 h (=deactivated)

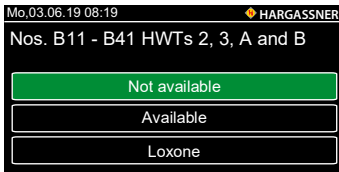

No. B11-B39b: Additional HWTs  
 B11 - B19b: When using an extension module **1**  
 B21 - B29b: When using an extension module **2**  
 B31 - B39b: When using a heat circuit board **A**  
 B41 - B49b: When using a heat circuit board **B**  
 ☞ Setting options: See commissioning engineer parameters **B1 - B9**

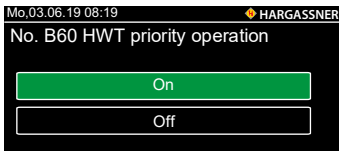

No. B60 HWT priority operation for quick HWT loading  
 ☞ For heat circuits with pumps, the heat circuit pumps are switched off throughout HTW priority operation. No heat is transferred from the boiler to the heat circuits  
 ☞ The heat circuit flow temperatures for heat circuits with mixers and pumps are reduced throughout priority operation

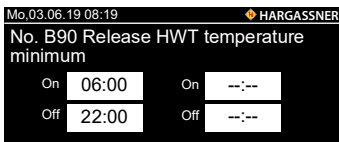

No. B90 HWT loading outside the loading times  
 ☞ When the HWT temperature drops below the minimum HWT temperature (commissioning engineer parameter B3)

### 10.3.1 Fresh-water station

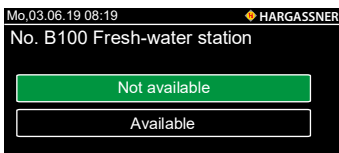

No. B100 Fresh-water station  
 ☞ Set the parameter to **Available** if a fresh-water station is available

Commissioning engineer parameters **B101 to B108** are only activated when commissioning engineer parameter **B100** is on **Available**.  
 ⇒ [To specify these settings, see the FWS fresh-water station operation manual](#)

## 10.4 Parameter C - accumulator

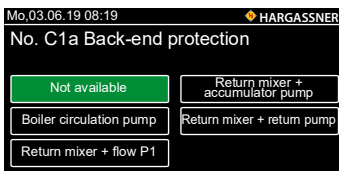

No. C1a Back-end protection

- Back-end protection not available
- Boiler circulation pump
- Return mixer with district line pump 1
- Return mixer with accumulator loading pump
- Return mixer with return pump (hydraulic separator)

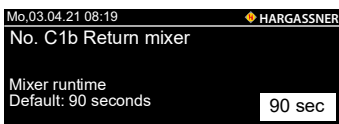

No. C1b Mixer runtime  
 ☞ Specifying the actual mixer runtime  
 ☞ Range: 10 - 300 sec.

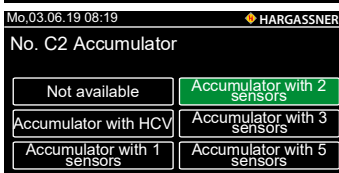

No. C2 Accumulator

- Not available
- Accumulator with heat circuit valve  
 ☞ For low-temperature heat circuits, (e.g. floor or wall circuits)
- Accumulator with 1 sensor  
 ☞ For a hydraulic scheme with accumulator unloading control
- Accumulator with 2 sensors  
 ☞ For a hydraulic scheme with loading and unloading control
- Accumulator with 3 or 5 sensors  
 ☞ For an accumulator diagram with loading (partial-load operation) and unloading control

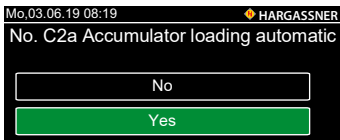

No. C2a Accumulator loading automatic  
 ☞ Specifying whether the accumulator should be loaded automatically

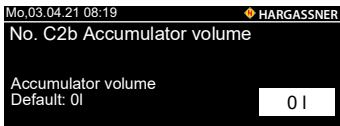

No. C2b Accumulator volume  
 ☞ Setting the accumulator volume in litres

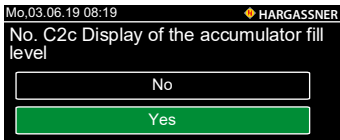

No. C2c Display of the accumulator fill level  
 ☞ Specifying whether the accumulator fill level should be displayed

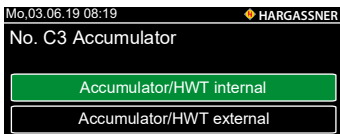

No. C3 Accumulator

- Accumulator / HWT internal (accumulator tank with integrated HWT - domestic hot water coil or external domestic hot water heat exchanger)  
 ☞ For on-site differential control between accumulator and HWT, set to **accumulator / HWT internal**
- Accumulator / HWT external (external HWT)

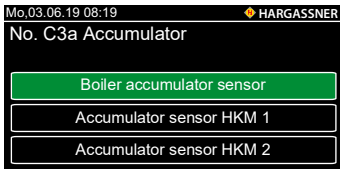

No. C3a Selection of the accumulator sensor connection

- **Accumulator sensor for boiler:** Accumulator sensor will be connected to the main board
- **Accumulator sensor for HKM 1 and 2:** Accumulator sensor will be connected to the extension module

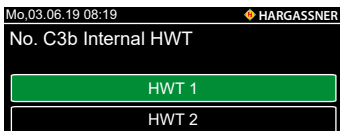

No. C3b Internal HWT

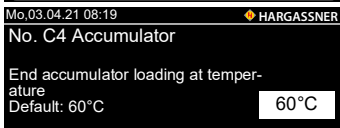

No. C4 End accumulator loading (measured on accumulator sensor below)  
 ☞ Display only when commissioning engineer parameter **C2** is set with **2, 3 or 5 sensors**  
 ☞ If heat is requested, the accumulator is loaded to its target temperature **C4** = 60°C (bottom accumulator sensor)

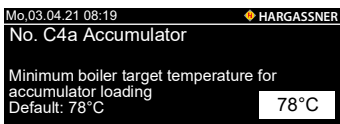

No. C4a Accumulator  
 ☞ Presetting the boiler target temperature for accumulator loading  
 ☞ Display only when commissioning engineer parameter **C2** is set with **2, 3 or 5 sensors**

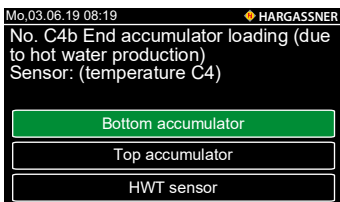

No. C4b End accumulator loading when temperature (commissioning engineer parameter C4) has been reached on the selected sensor  
 ☞ Display only when commissioning engineer parameter **C2** is set with **2, 3 or 5 sensors**  
 ☞ Display HWT sensor only when **C3** commissioning engineer parameter is set to **HWT internal**

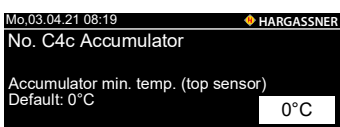

No. C4c Accumulator minimum temperature  
 Lower accumulator limit temperature  
 ☞ When the accumulator temp is below the set value (accumulator sensor top), accumulator loading starts  
 ☞ **C4c** must be at least 10°C lower than **C4a**

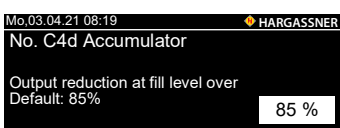

No. C4d Accumulator output reduction  
 ☞ When the preset accumulator fill level is reached, the system power is reduced

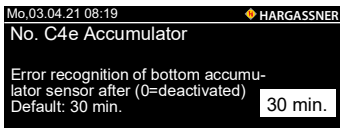

No. C4e Accumulator error recognition

- ☞ A notice is issued when the mixer has been completely open for the preset time and the temperature at the bottom accumulator sensor is 11°C below that of the return sensor

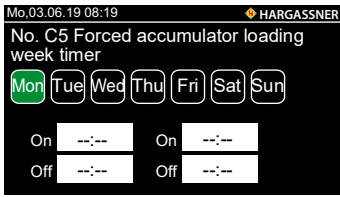

No. C5 Accumulator forced loading

- ☞ Setting the time for accumulator forced loading
- ☞ Displays only if parameter **C2** is set to **AT with 2 sensors** or **AT with 3 sensors**
- ☞ Accumulator forced loading at the set time and activated set temperature
- ☞ E.g. for peak loads in the morning (e.g. 04:00 - 10:00)

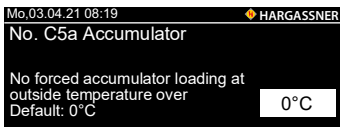

No. C5a Accumulator forced loading

- ☞ No accumulator forced loading when the set outside temperature is exceeded

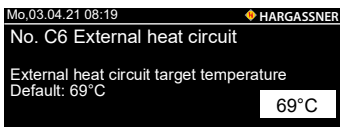

No. C6 External heat circuit

- ☞ Adjusting the boiler set temperature for an activated external heat circuit
- ☞ If the value is changed and parameter **C7** is set to **External pump**, service parameter **L5** = 50 °C must be adjusted as well
- ☞ L5 ca. 5 - 10 °C less than **C6a**

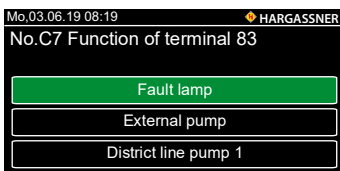

No. C7 Function of terminal 83

- ☞ Set the function of the output at terminal 83 on the main board
- Fault lamp
  - ☞ Lights up for all faults
- Pump external heat circuit
  - ☞ System is heated to the temperature set in parameter **C6a**
  - ☞ External heat circuit pump is switched on at release temperature (service parameter **L5**)
- District line pump
  - ☞ District line runs when a heat circuit or HWT pump parameterised for **district line** is switched on

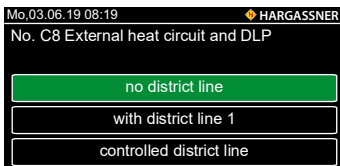

No. C8 External heat circuit and DLP

- ☞ District line pump runs if one of the referred pumps run

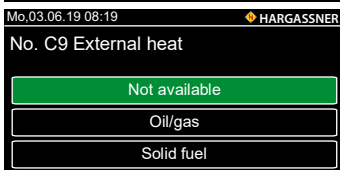

No. C9 External heat

- Not available
- Oil/gas boiler
- Solid fuel boiler

## 10.5 Parameter D - general

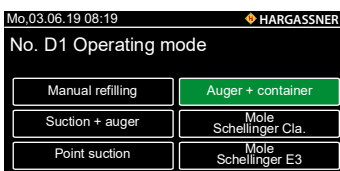

No. D1 Setting the pellet boiler operating mode

- Day hopper is filled manually
- Day hopper is automatically filled via auger and vacuum turbine
- Boiler is automatically filled by the direct auger
- Day hopper is automatically filled via point suction
- Day hopper is filled by the direct auger
- Day hopper is filled automatically by the **Schellinger** external extraction system

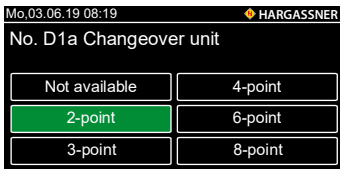

No. D1a Changeover unit for feeding wood pellets

- Not available
- 2-point / 3-point / 4-point / 6-point / 8-point

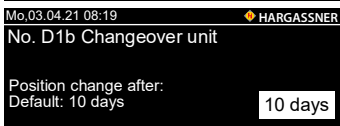

No. D1b Position change of changeover unit

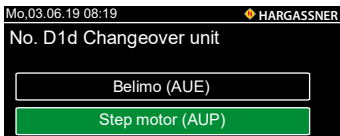

No. D1d Set the changeover unit's system

- Belimo (AUE)
- Step motor (AUP)



No. D1f Switching on the automatic pellet consumption display

- ☞ When **Available** is selected, customer parameter no. 30 and the extended **Info/consumption display** info page are also enabled

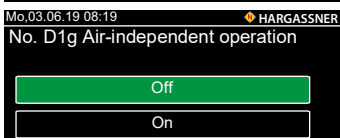

No. D1g Air-independent operation

- ☞ Set, if the pellet boiler is manufactured for air-independent operation
- ☞ AIO note, see type plate

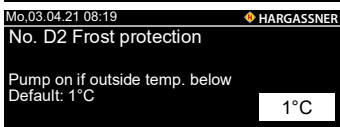

No. D2 Frost protection

- ☞ Heat circuit pumps are switched on when the value drops below the set value
- ☞ Heat circuits with mixers are adjusted to the **D3** commissioning engineer parameter temperature



No. D3 Frost protection

- ☞ Flow temperature when commissioning engineer parameter **D2** is not reached

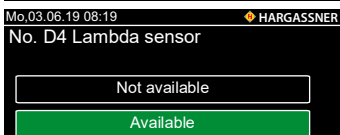

No. D4 Lambda sensor

- ☞ Specify whether or not the system is equipped with a lambda sensor
- ☞ If the lambda sensor is defective, this setting can be changed to **Not available**



No. D5 Changeover day reduction

- ☞ Switchover point at which time the outside temperature reduction logic changes from night to day settings (customer parameters 12 and 13)

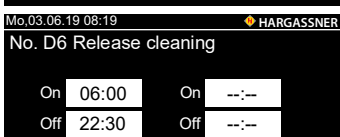

No. D6 Cleaning device

- ☞ Automatic cleaning is only performed within the set time
- ☞ Irritating noise during the cleaning

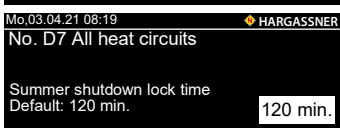

No. D7 Summer shutdown lock time of all heat circuits

- ☞ Duration of the switch-off delay for summer switch-off
- ☞ If the outdoor temperature rises above 16°C for the duration of the set time (customer parameter no. 11), the system switches off



No. D8 Summer time

- ☞ Automatic changeover from summer to winter time

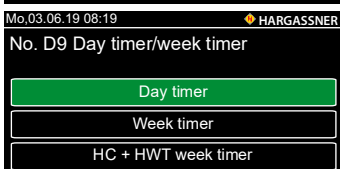

No. D9 Day timer/week timer

- ☞ Display day or week timer in the customer settings
  - Day timer: Heat circuits and HWT on day timer
  - Week timer: Heat circuits on week timer, HWT on day timer
  - HC + HWT week timer: Heat circuits and HWT on week timer

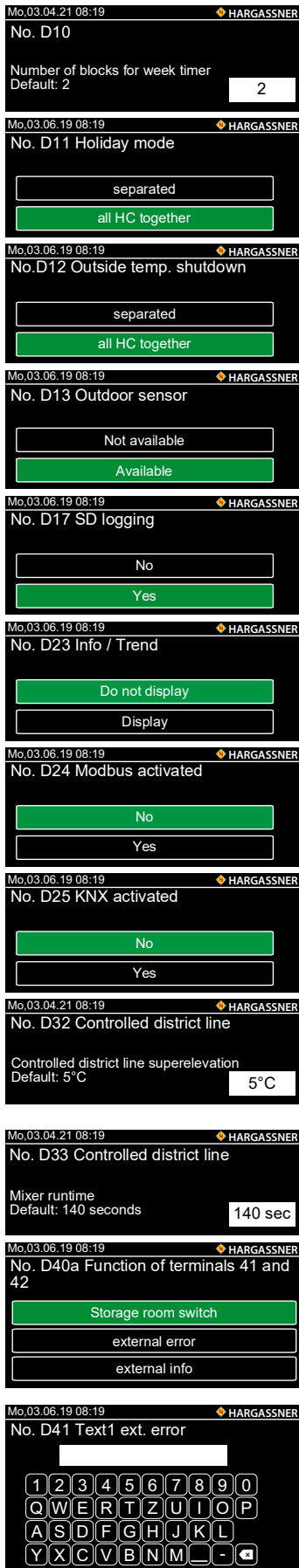

No. D10 Number of blocks for week timer

- ☞ Display in the customer settings
- ☞ Range: 1 - 7

No. D11 Holiday mode

- ☞ Switch off all the heat circuits together or separately

No. D12 Outside temp. shutdown

- ☞ Outdoor temperature switch-off values individually or for all heat circuits together

No. D13 Outdoor sensor

- ☞ Set whether an outdoor sensor is available
- ☞ Set to **Not available** for active, external heat circuits

No. D17 SD logging

- ☞ Only visible when a DS card is inserted
- ☞ Records the system's measurement data

No. D23 Info / Trend

- ☞ Specify whether the graphical representation of records in the **Info / History** menu field should be shown

No. D24 Modbus activated

- ☞ Specifying whether a Modbus is available
- ☞ Only visible when a Modbus ID card is inserted

No. D25 KNX activated

- ☞ Specifying whether a KNX building controller is available
- ☞ Only visible when a KNX ID card is inserted

No. D32 Controlled district line

- ☞ If there is a demand from a heat circuit - parameterised on a controlled district line - then the flow temperature of the controlled district line is increased by the set value

No. D33 Controlled district line mixer runtime

- ☞ Mixer runtime from the closed to the open status
- ☞ Range: 10 - 300 sec.

No. D40a Function of terminals 41 and 42

- ☞ Set the function of the input at terminals 41 and 42 on the main board
  - Storage room switch
  - External error
  - External info

No. D41 Text1 external error

- ☞ Text of the external error output on the display

No. D42 Text2 external error

- ☞ Text of the external error output on the display

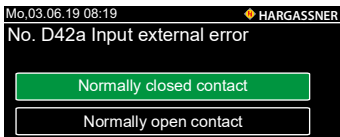

No. D42a Input external error

☞ Setting whether the external input is normally closed or normally open

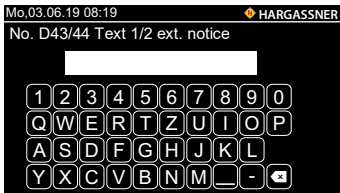

No. D43 Text 1 external notice

☞ Text of the external notice output on the display

No. D44 Text 2 external notice

☞ Text of the external notice output on the display

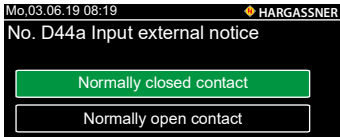

No. D44a Input external notice

☞ Setting whether the external input is normally closed or normally open

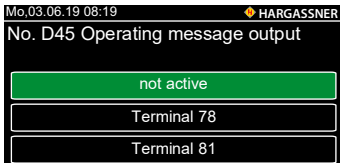

No. D45 Operating message output

☞ If lambda heating is active, an operating message signal is issued at the set terminal

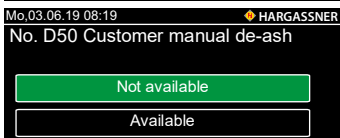

No. D50 Customer manual de-ash

☞ Set whether de-ashing is carried out manually

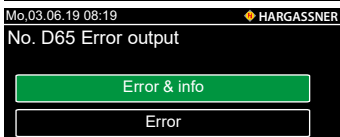

No. D65 Error output

☞ Used to specify whether the error output will emit a signal with messages and errors or just with errors (terminal 97)

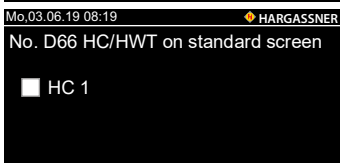

No. D66 Heat circuit / HWT on standard screen

☞ Used to specify which heating circuits and HWTs will be displayed on the standard screen

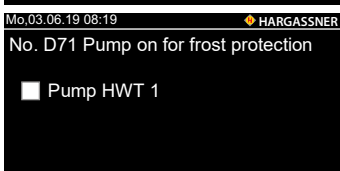

No. D71 Pump on for frost protection

☞ Selection of the pumps that are active during frost protection

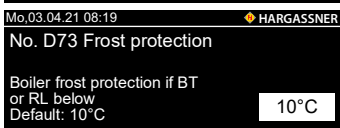

No. D73 Frost protection

☞ If the boiler is in frost protection and the boiler temperature or return temperature falls below this value, the return mixer is opened and the selected pumps (D71) are switched on

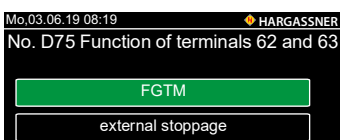

No. D75 Function of terminals 62 and 63

☞ Set whether the input is used as a flue gas temperature monitor or as an external stoppage

## 10.6 Parameter E - languages

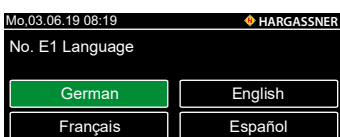

No. E1 Language

☞ Language selection



## 10.7 Parameter G - differential control

Mo.03.06.19 08:19 HARGASSNER

No. G1 Differential controller function

Not available External heat boiler

1 circuit

2 circuits

### No. G1 Differential controller function

- Not available
- 1 circuit
- 2 circuits
- External heat boiler

Mo.03.06.19 08:19 HARGASSNER

Differential controller

No. G2 Differential controller active at heat source Default: 30°C 30°C

No. G2a Differential controller shutdown at heat source Default: 95°C 95°C

### No. G2 Differential controller switch-on temp.

Set temperature the heat source sensor has to reach for differential controller to start regulating.

### No. G2a Differential contr. switch-off temp.

Set temperature the heat source sensor has to reach for differential controller to stop regulating.

☞ Differential controller shutdown to protect boiler

Mo.03.04.21 08:19 HARGASSNER

No. G2b Differential controller

Differential controller active at heat source Default: 55°C 55°C

### No. G2b Differential controller's switch-on temperature

☞ Only active if **G1** is on **External heat boiler**

Set temperature the heat source sensor has to reach for differential controller to stop regulating.

Mo.03.06.19 08:19 HARGASSNER

No. G4 Circuit 1 (priority circuit) sensor selection

IO36 terminal 209/210 Bottom accumulator sensor HWT sensor A

Top accumulator sensor Accumulator sensor TPMO

Accumulator sensor Centre Accumulator sensor TPMU

### No. G4 Circuit 1 (priority circuit) sensor selection

Set which sensor is used for differential control.

- Temperature will be determined using the heat source sensor and the sensor selected here

Mo.03.04.21 08:19 HARGASSNER

No. G4a Differential controller

Superelevation of heat source (circuit 1) Default: 10°C 10°C

### No. G4a Superelevation of heat source

Used to set heat source's superelevation.

☞ If the heat source exceeds the first circuit's temperature plus the superelevation specified here, the pump will be activated

Mo.03.04.21 08:19 HARGASSNER

No. G4b Differential controller

Hysteresis (circuit 1) Default: 5°C 5°C

### No. G4b Circuit 1 hysteresis

Used to set the heat source's hysteresis.

☞ If the heat source drops below the circuit's temperature plus the superelevation minus the hysteresis specified here, the pump will be switched off

Mo.03.04.21 08:19 HARGASSNER

No. G4c Differential controller

Shutdown of circuit 1 Default: 65°C 65°C

### No. G4c Circuit 1 shutdown

Specify circuit 1's shutdown temperature.

☞ If circuit 1 reaches this shutdown temp., the pump will be switched off

### Nos. G5 - G5c Circuit 2

Same settings as **G4 - G4c**.

Mo.03.06.19 08:19 HARGASSNER

No. G5d Parallel operation circuit 1+2

No (without valve)

No (valve available)

Yes

### No. G5d Parallel operation circuit 1+2

Definition of parallel operation of the two circuits.

- **No (no valve available)**: Pumps for two circuits will not run simultan.
- **No (valve available)**: A changeover valve will switch between two circuits
  - ☞ Only one pump is being used for both circuits
- **Yes**: The pumps for both circuits can be actuated at the same time
- **Caution**: For two-circuit operation with a pump and a changeover valve, select **No (valve available)**

Mo.03.04.21 08:19 HARGASSNER

No. G5e Differential controller

Changeover to circuit 2 if difference for circuit 1 is smaller than Default: 4°C 4°C

### No. G5e Temp. difference for changeovers to circuit 2

Specify temp. differ. betw. circuit 1 and heat source dictating if changeover to circuit 2 occurs.

☞ If this temperature difference is dropped below, the controller will switch to circuit 2 after the period specified in **G5g**

Mo.03.04.21 08:19 HARGASSNER

No. G5f Differential controller

Changeover to circuit 2 if circuit 1 is over Default: 60°C 60°C

### No. G5f Temperature for changeovers to circuit 2

Specify circuit 1 temp. dictating if changeover to circuit 2 occurs.

☞ If this temperature is reached, controller will switch to circuit 2

Mo.03.04.21 08:19 HARGASSNER  
**No. G5g Differential controller**  
 Time delay for changeover to circuit 2  
 Default: 1 min.

**No. G5g Time delay for changeovers to circuit 2**

Used to specify the time delay for changeovers to circuit 2.

☞ If **G5e** and **G5f** are fulfilled in this period, the controller will switch to circuit 2

Mo.03.06.19 08:19 HARGASSNER  
**No. G6 External heat boiler**

**No. G6 External heat boiler switch-on**

☞ Only active if **G1** is on **External heat boiler**

☞ Return temp. regulated by sensor specified in **G6e**

Mo.03.04.21 08:19 HARGASSNER  
**No. G6a Differential controller**  
 Mixer runtime  
 Default: 120 seconds

**No. G6a External heat boiler mixer runtime**

Set the external heat boiler's mixer run time.

Mo.03.04.21 08:19 HARGASSNER  
**No. G6b Differential controller**  
 Observe the return temperature of the heat source according to the manufacturer  
 Default: 60°C

**No. G6b External heat boiler return temp.**

☞ Return temperature of heat source according to the manufacturer

Mo.03.04.21 08:19 HARGASSNER  
**No. G6c Differential controller**  
 Info when return temperature is not reached  
 Default: 50°C

**No. G6c Message if external heat boiler return temp. is not reached**

Set the return temperature the external heat boiler has to drop below for a message to be issued.

Mo.03.04.21 08:19 HARGASSNER  
**No. G6d Differential controller**  
 Time for info  
 Default: 60 min.

**No. G6d Period ext. heat boiler message**

Used to specify how long the external heat boiler's return temperature has to be below the temperature specified in **G6c** for a message to be issued.

Mo.03.06.19 08:19 HARGASSNER  
**No. G6e Diff. sensor S2**

**No. G6e External boiler S2 sensor selection**

Set which sensor is used for differential control.

☞ Temperature will be determined using the heat source sensor and the sensor selected here

Mo.03.04.21 08:19 HARGASSNER  
**No. G6f Differential controller**  
 Superelevation of heat source (External heat boiler)  
 Default: 10°C

**No. G6f Superelevation of heat source**

Set from which temperature superelevation the differential controller is activated.

☞ If external heat boiler exceeds the circuit's temperature plus superelevation specified here, the pump will be activated

Mo.03.04.21 08:19 HARGASSNER  
**No. G6g Differential controller**  
 Hysteresis (external heat boiler)  
 Default: 5°C

**No. G6g External heat boiler hysteresis**

Set the hysteresis of the external heat boiler.

☞ If the external heat boiler drops below the circuit's temperature plus the superelevation minus the hysteresis specified here, the pump will be switched off

Mo.03.04.21 08:19 HARGASSNER  
**No. G7 Differential controller**  
 Safety circuit at heat source (sensor S1)  
 Default: 95°C

**No. G7 Safety contro**

Used to specify external heat boiler's maximum temperature.

☞ If external heat boiler exceeds this temperature, pump will be activated or remain activated and mixer will open

**Nos. G11 - G17 External heat controller 2**

Same settings as **G1 - G7**.

**Nos. G21 - G28g PWM diff. controller**

⇒ [See installation manual for S additional board](#)

## 11 Optional remote controls

Using a remote control makes it easy to adjust the room temperature and also the heating and setback settings. The heating temperatures and times can be set and changed with the FR35 and FR40 digital remote controls. One heat circuit may be parametrised per remote control, which can be parametrised with or without using room temperature.

- 1 heat circuit on the extension board (**HC A** digital remote control only)
- 2 heat circuits per extension module (**HKM 0 - 2**)
- 2 heat circuits per heat circuit controller (**HKR 0 - 15**)

### 11.1 Digital remote control FR40

With the FR40, all the heat circuit functions available on the boiler can be set from wherever the remote control is in the user's living space.

#### Operation modes:

##### OFF



The heat circuit is switched off (except for frost protection).

##### AUTOMATIC



The heat circuit is operated according to set times.

##### PERMANENT REDUCTION (in automatic mode)



The heat circuit is in permanent reduced mode.

##### PERMANENT HEATING (in automatic mode)



The heat circuit is in permanent heating mode.

##### 1x HEATING (heating on a single occasion)



The heat circuit switches to permanent heating mode on a single occasion and automatically reverts to automatic mode at the next preset heating time.

##### 1x REDUCTION (reduction on a single occasion)



The heat circuit switches to permanent reduced mode on a single occasion and automatically reverts to automatic mode at the next preset heating time.

##### Fine adjustment of room temperature:



Increase of up to 3°C



Decrease of up to 3°C

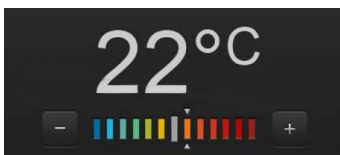
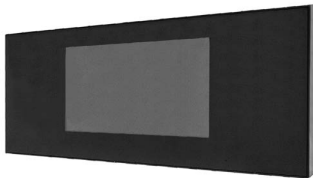

## 11.2 Digital remote control FR35



The remote control is also available in a wireless version.

The following selection options are available on the remote control only when the boiler is in **Automatic** mode:

- Selection of the heat circuit's operating mode
- Selection of modes at remote control

### Operation modes:

#### OFF



The heat circuit is switched off (except for frost protection).

#### AUTOMATIC



The heat circuit is operated according to set times.

#### PERMANENT REDUCTION (in automatic mode)



The heat circuit is in permanent reduced mode.

#### PERMANENT HEATING (in automatic mode)



The heat circuit is in permanent heating mode.

#### 1x HEATING (heating on a single occasion)



The heat circuit switches to permanent heating mode on a single occasion and automatically reverts to automatic mode at the next preset heating time.

#### 1x REDUCTION (reduction on a single occasion)



The heat circuit switches to permanent reduced mode on a single occasion and automatically reverts to automatic mode at the next preset heating time.

#### Fine adjustment of room temperature:



+



- : Increase / decrease by 2 or 3 °C

#### Fault lamp:



Lights up if an error occurs on the boiler

#### Display parameters:

Select which temperature should be shown on the room device (FR35).

- HWT temperature 1 - A
- Accumulator fill level

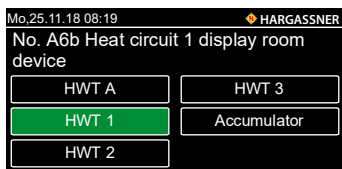

## 11.3 Analogue remote control FR25 (only on HKM or HKR heat circuits)



The following selection options are available on the remote control only when the boiler is in Automatic mode



### Selection of the heat circuit's operating mode with the rocker switch



The heat circuit switches to permanent reduced mode.



The heat circuit switches to day / week mode.



The heat circuit switches to permanent heating mode.

### Fine adjusting the room temperature with the rotary knob









Increase / decrease by 2 or 3°C.

#### Fault lamp:



Lights up if an error occurs on the boiler.

## Chapter IV: Cleaning

 	<p style="text-align: center;"><b>D A N G E R</b></p> <p><b>Risk of injury due to moving parts</b></p> <ul style="list-style-type: none"> <li>• Refrain from accessing augers or motors when the boiler is switched on</li> <li>• Fix and lock the ash container on the system correctly</li> <li>• Do not work on the boiler while people are in the danger zone           <ul style="list-style-type: none"> <li>☞ Secure / lock storage room</li> </ul> </li> <li>• Only clean the augers and remove blockages using suitable tools and when the main power switch is turned off and locked</li> <li>• Wear safety shoes</li> <li>• Observe storage room sticker</li> </ul>
	<p style="text-align: center;"><b>D A N G E R</b></p> <p><b>Electric shock from contact with live terminals</b></p> <ul style="list-style-type: none"> <li>• Observe information signs</li> <li>• Disconnect the power supply prior to any cleaning or maintenance work           <ul style="list-style-type: none"> <li>☞ Switch off and lock the main power switch</li> </ul> </li> </ul>
  	<p style="text-align: center;"><b>D A N G E R</b></p> <p><b>Risk of injury from reaching into the danger zone during recommissioning</b></p> <ul style="list-style-type: none"> <li>• After triggering main power switch, do not reach into the danger zone without thinking</li> <li>• Before carrying out any work on the system, turn off the main power switch and prevent it from being turned on again by securing it with a padlock. Keep the key with you for the duration of your work. Hand out the key for a lock to the authorised person only</li> <li>• Rectify error</li> <li>• When re-commissioning, check that no person is in the danger zone</li> </ul>
 	<p style="text-align: center;"><b>D A N G E R</b></p> <p><b>Risk of burning from inflammable materials</b></p> <ul style="list-style-type: none"> <li>☞ Do not spray any inflammable sprays on hot surfaces (e.g. lubricating moving parts in the combustion chamber)           <ul style="list-style-type: none"> <li>☞ Spray drops can cause explosive fire</li> </ul> </li> <li>• Do not use any inflammable lubricants</li> <li>• Allow system (combustion chamber) to cool down</li> </ul> <p><b>Risk of fire in the vacuum cleaner</b></p> <ul style="list-style-type: none"> <li>• Let the ash cool down prior to vacuum cleaning</li> </ul>

### ATTENTION



#### Formation of dust and smoke due to system leakages

- Clean sealing surfaces with industrial alcohol and a dry and soft (scratch-free) cloth only
- Make sure the cleansing material is evaporated before commissioning

#### Dirt and boiler breakdown due to escaping ash

- Empty and clean according to the maintenance instructions
- Ash may escape when the ash box is overfilled
- Ash box must be positioned correctly and locked on both sides

- ☞ Small cracks may occur in the refractory in regular operation. These are stress cracks that form an expansion joint. This cracking is important and does not lead to any functional impairment. The customer is therefore not entitled to claim for this while the boiler is under guarantee
- ☞ The specified cleaning and maintenance intervals are absolutely necessary for safe and clean operation of the system. Observe the state regulations and resulting chimney sweep's inspection and sweeping intervals dictated by these regulations

## 1 Maintenance contract

If you sign a maintenance contract with Hargassner Ges mbH, the annual cleaning and maintenance takes place during the annual service performed by personnel authorised by Hargassner. Service must be carried out regularly by the manufacturer (every one to three years) depending on your country's regulations. This service must be carried out by the manufacturer or by trained and authorised individuals.

- ☞ To ensure optimum operation of the system, extensive cleaning of the boiler is required
  - ☞ At least once a year
  - ☞ After a set number of operating hours in the event of an error
- ☞ The cleaning intervals will change or shorten depending on the composition of the fuel and if low-grade material is used

## 2 Cleaning

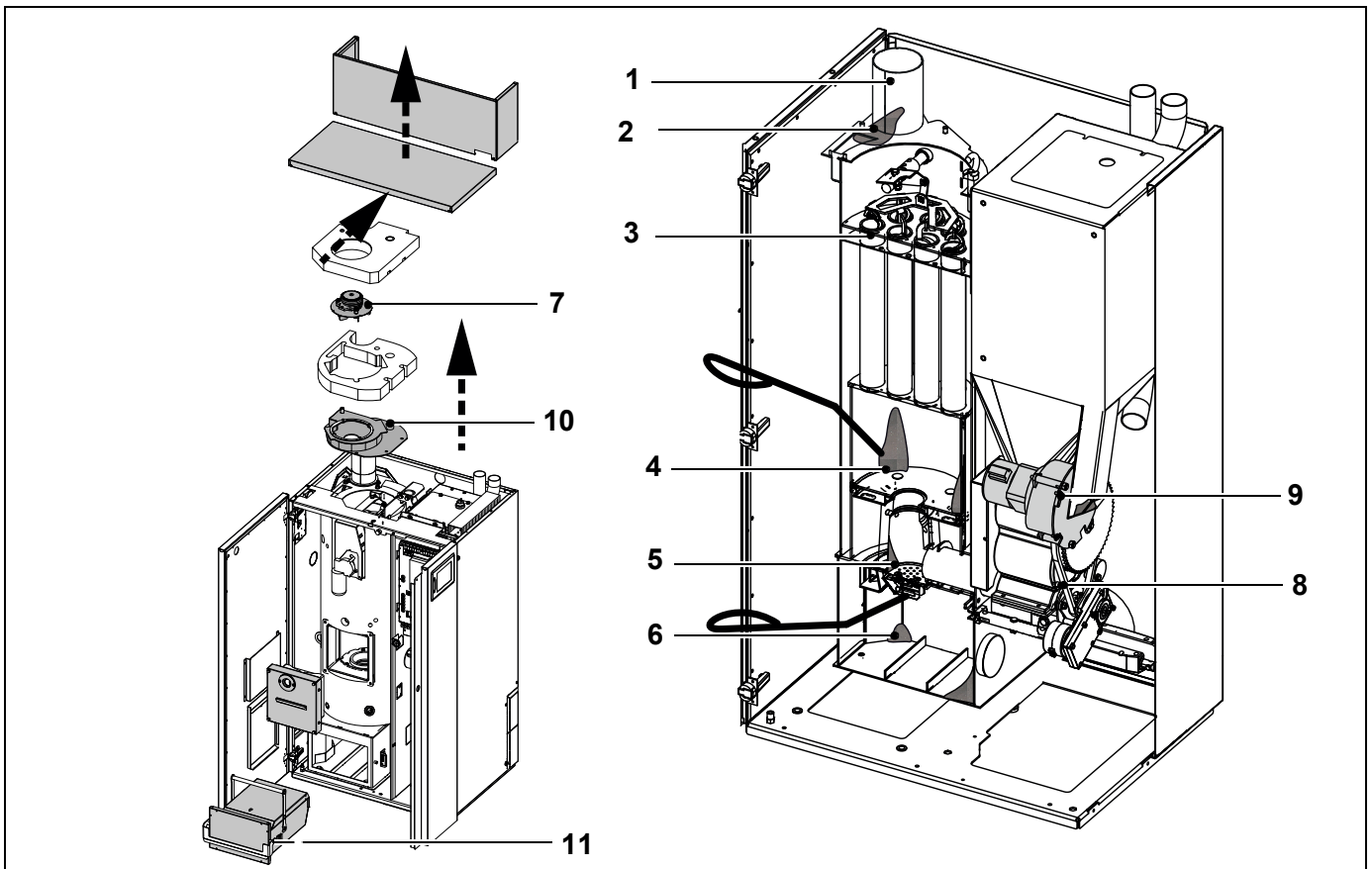

Item	Maintenance tasks	Interval (a = annually <sup>a</sup> )
1	Clean flue pipe	2x a
2	Clean deflection box	2x a
3	Tap off the turbulators and clean the turbulator space	1x a
4	Clean post combustion chamber with poker (visual check via inspection glass)	1x a (as required)
5	Clean combustion chamber with poker	1x a (as required)
6	Remove ash pan and clean out ash under the grate	1x a
7	Dismount exhaust fan and clean housing and impeller	1x a
8	Lubricate stoker chain and check chain tension	1x a
9	Clean pellet vacuum turbine	1x a
10	Disconnect, remove and clean lambda sensor	1x a
11	Empty ash pan	as required

a. At least once annually, at the latest after 4000 full-load hours, 8000 partial-load hours or after a message has appeared on the control unit

☞ Boiler monitoring and cleaning intervals are based on the operation hours and fuel quality. Observe country-specific regulations and the inspection and sweeping intervals dictated by these

## IV Cleaning

### 2.1 Preparation for cleaning

- Switch off boiler at the control unit (BCE) (**Off** operating mode)
- Let boiler cool down
- Disconnect the boiler from the power supply (**Off** main switch)
- Open left cover door

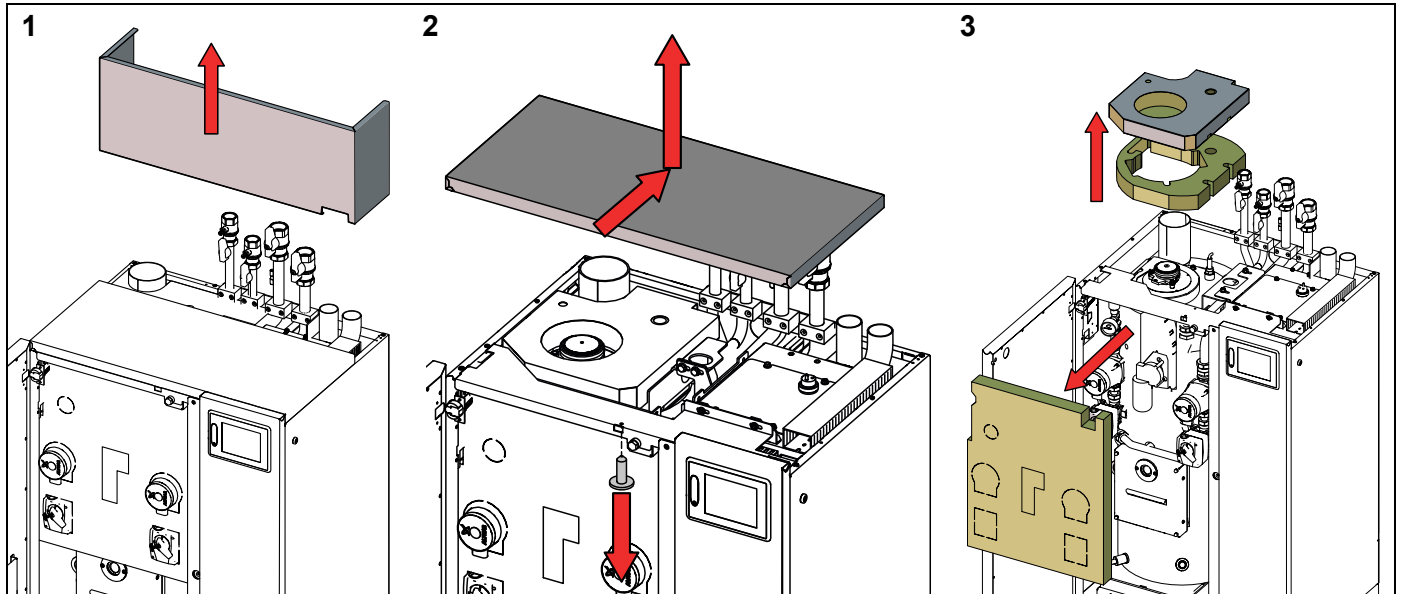

- Remove top maintenance lid
- Remove hydraulic panel upwards (1)
- Loosen screw from maintenance lid (2)
- Push maintenance lid slightly backwards and lift upwards to remove
- Remove cover and insulation pieces (3)

### 2.2 Cleaning the flue pipe and the deflection box

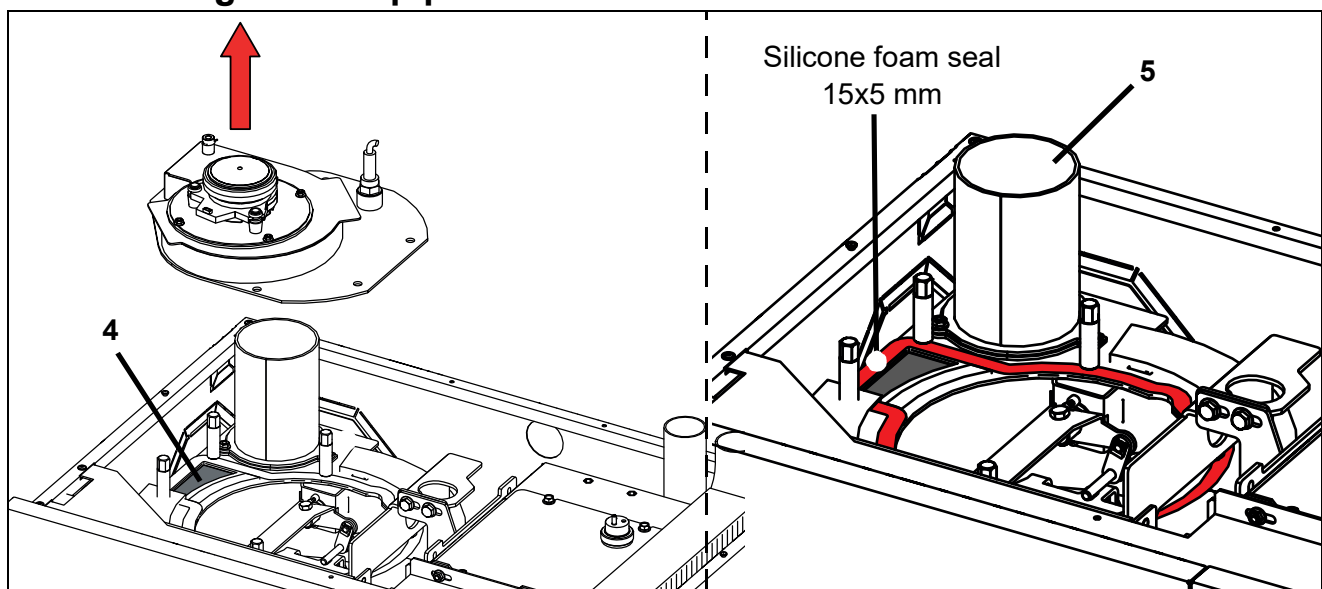

- Unplug lambda sensor and exhaust fan
  - ☞ Pay attention to plugs
- Dismount exhaust fan housing
- Clean deflection box (4) and flue pipe (5)
  - ☞ Replace the 15x5 mm silicone foam seal if necessary

## 2.3 Cleaning the turbulators and the turbulator space

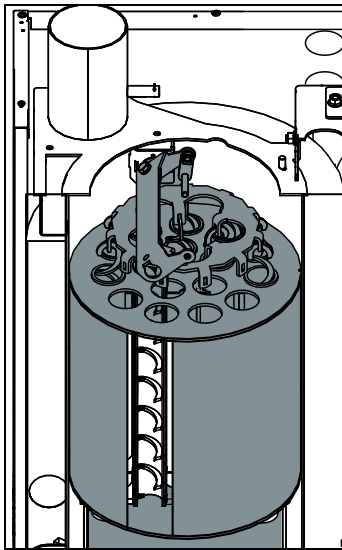

- Dismount exhaust fan housing
  - ⇒ See "Cleaning the flue pipe and the deflection box" on page 58.
- Tap off the turbulators and clean the turbulator space

## 2.4 Cleaning the exhaust fan

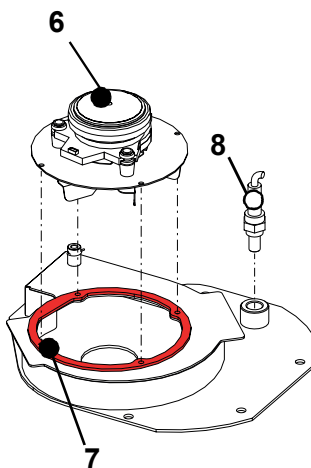

- Remove the exhaust fan (6)
- Clean dirt from housing and impeller
  - ☞ Do not clean using compressed air
- ☞ If necessary, replace 8x3 mm ceramic fibre seal (7)

## 2.5 Cleaning the lambda sensor

	<b>NOTE</b>
	<ul style="list-style-type: none"> <li>• Do not "tap" the sensor!</li> <li>• Do not blow off with compressed air</li> <li>• Do not touch the sensor with sharp items and do not use any chemicals for cleaning (brake cleaning fluid, etc.)</li> </ul>

- Unscrew lambda sensor (8) from exhaust fan housing
- Point sensor head downwards and wipe with a moist cloth
  - ☞ Debris falls down

## 2.6 Cleaning the combustion chamber and post combustion chamber

	<b>NOTE</b>
	<p><b>Cleaning the combustion chamber when the exhaust fan is running</b></p> <ul style="list-style-type: none"><li>☞ Ash can be whirled up during cleaning, which can be sucked out through the running exhaust fan</li><li>☞ Less dirt in the boiler room</li></ul>

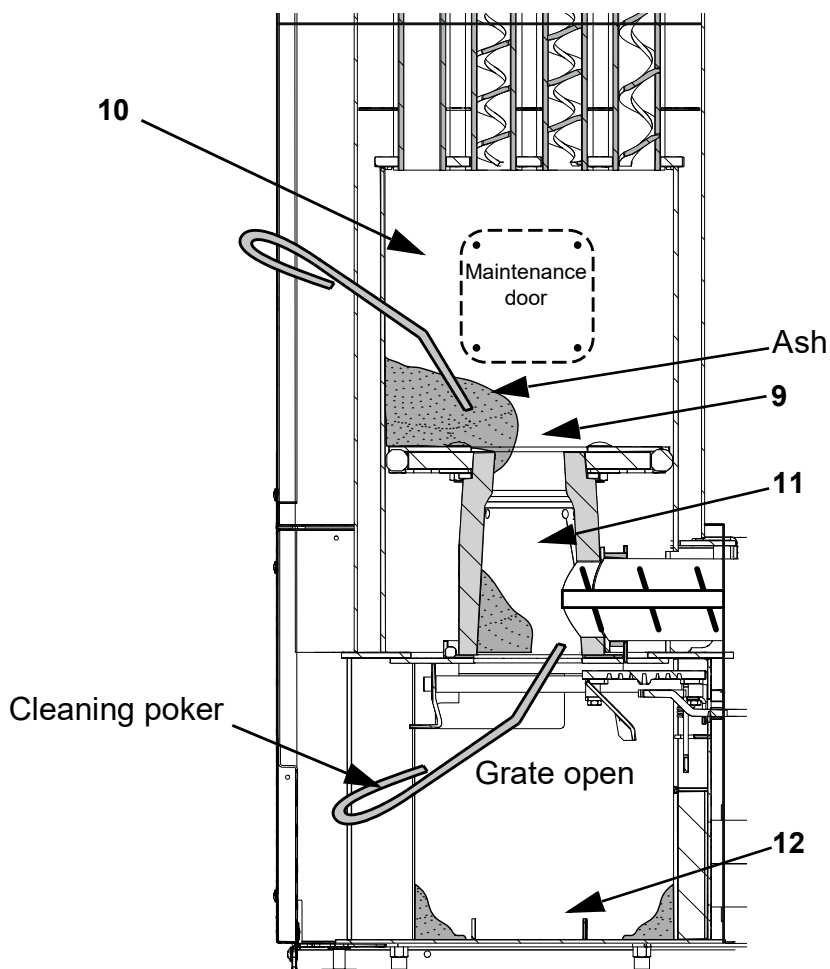

- Select function no. 2 with the selector switch position at **Manual** and press the **Open** button to completely open the sliding grate
- Open left cover door
- Check flame concentration hole (**9**) (opening in refractory through which the flame enters the post combustion chamber)
  - ☞ If the flame concentration hole is jammed or the post combustion chamber (**10**) is very dirty, disassemble the front maintenance door (M6 cap nuts) and clean the post combustion chamber using the cleaning poker
- Remove ash pan and clean any dirt from combustion chamber (**11**) using cleaning poker
- Clean ash collection area (**12**)

## 2.7 Cleaning the pellet vacuum turbine

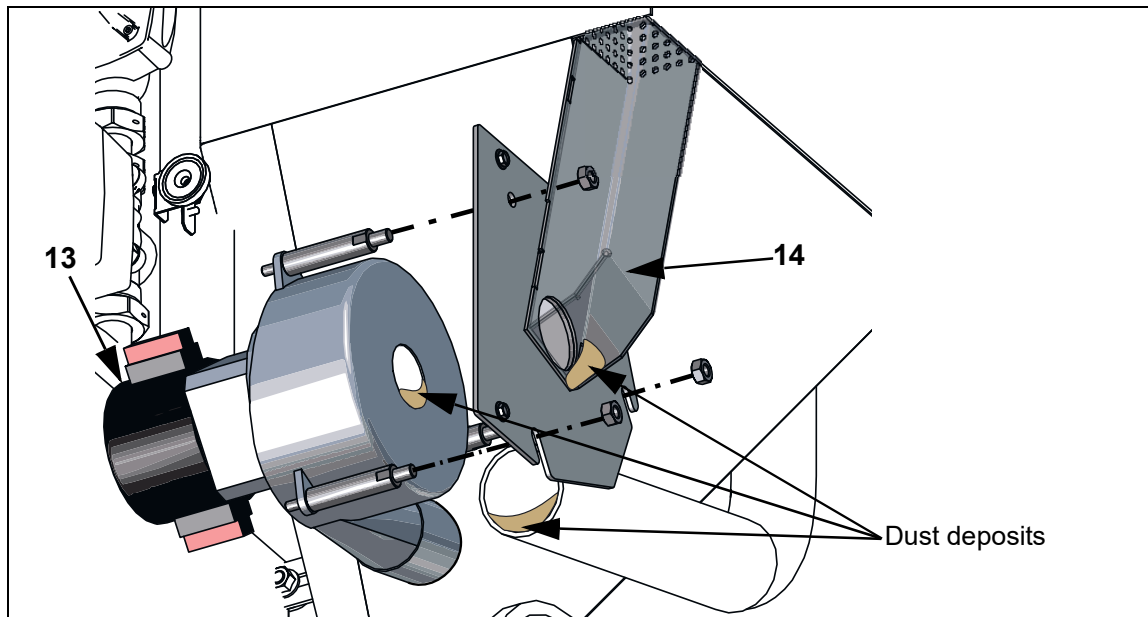

- Dismount pellet vacuum turbine (13)
- Loosen the three fixing points from the vacuum turbine
  - ☞ Studs remain on the vacuum turbine
- Loosen hose clamp from return air hose and remove hose from vacuum turbine
- Remove dust from vacuum turbine, channel (14) and return air hose
- Re-assemble system after cleaning

## 2.8 Replacing the carbon brushes of the pellet vacuum turbine

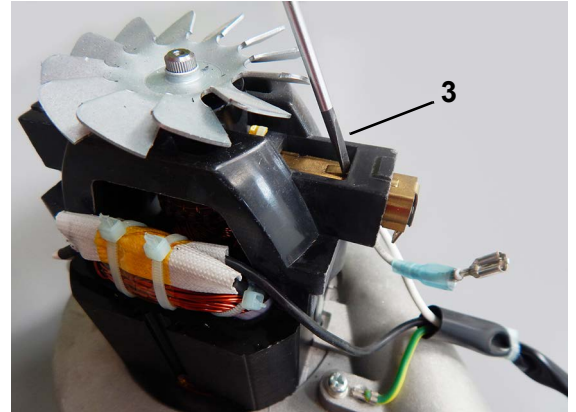
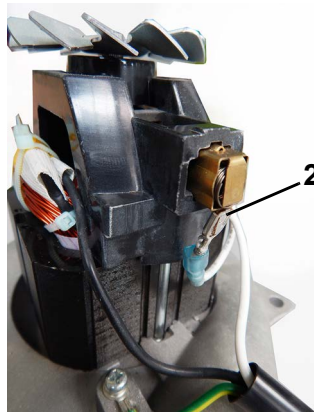

- Remove (1) housing cover
- Remove flat receptacle (2)
- Push in leaf spring (3) on carbon brush housing
- Pull out carbon brush
- Replace 2 carbon brushes with new ones
- Re-assemble in reverse order

### 2.9 Emptying the ash pan

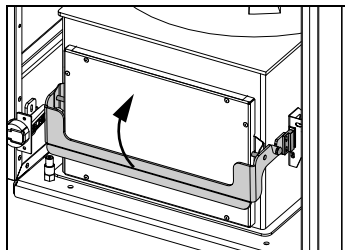

- Empty ash pan at regular intervals
  - ☞ Control unit displays **Empty ash pan**
  - ☞ If the ash pan is not emptied, the system is switched off after approx. 1 week and displays **Ash pan overfilled**
- To unlock the ash pan, pull the handle upward

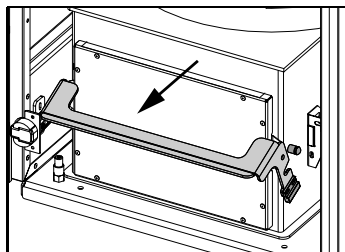

- Pull out the ash pan to the front

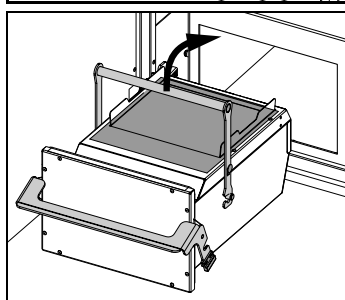

- Place the transport plate on the ash pan opening
  - ☞ The transport plate is located inside on the left cover door
- Fold transport handle upwards
  - ☞ The ash pan can now be easily transported
- To close and lock the ash box, proceed in reverse order
  - Fully close the ash pan and ensure that it is securely locked
- Acknowledge the message on the display after emptying the ash pan

## 3 Disposal information

### 3.1 Disposal of created ash

- ❑ Ash must be disposed of according to your national waste management regulations (Austria: AWG Waste Management Act)
  - ☞ If natural wood is used as a fuel, then the ash can be regarded as a high-quality mineral fertilizer and can be used for composting
  - ☞ **Caution:** watch out for ember pockets

### 3.2 Disposal of wear and spare parts

- ❑ Disposal of the wear and spare parts must be according to your national waste management regulations (Austria: AWG Waste Management Act).
  - ☞ Only use equivalent spare parts approved by Hargassner Ges mbH

### 3.3 Disposal of system components

- ❑ Ensure environmentally compatible disposal in accordance with country-specific regulations (Austria: AWG Waste Management Act)
- ❑ Recyclable materials must be cleaned and sorted before being passed on for recycling
  - System (boiler)
  - Fuel extraction system
  - Insulation material
  - Electrical and electronic parts
  - Plastics

## Chapter V: Troubleshooting

### ATTENTION



#### Injuries or damage to the boiler due to deviation from regular operation

- Contact the commissioning engineer/Hargassner immediately in case of higher power consumption, higher temperatures or vibrations of motors, unusual noises or smells, release of safety devices, etc.
- Perform mandatory maintenance and inspection tasks regularly

### 1 Information and error display

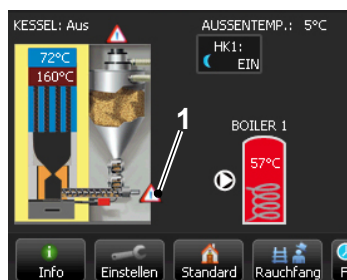

Information and error messages are displayed on the touchscreen.

- ☞ A warning triangle appears on the standard menu at the position where the error has occurred **(1)**
- ☞ Yellow triangle = information
- ☞ Red triangle = error

The following instructions for rectifying errors are intended for the system operator.

If it is not possible to rectify the error through the operator, the commissioning engineer / Hargassner must be informed.

### 2 Viewing the error list

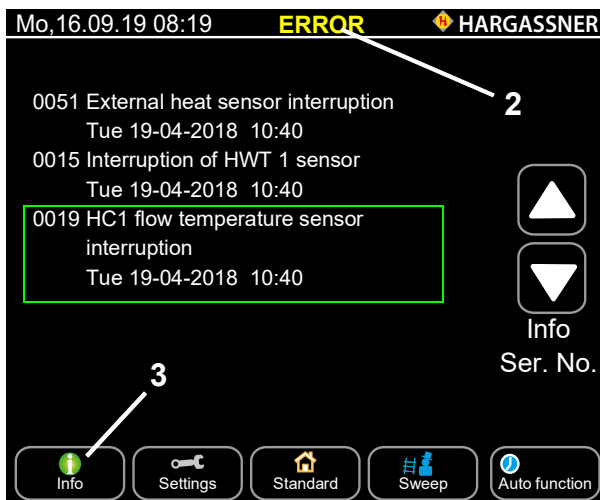

- ☐ If error messages occur, press **Error (2)**
  - ☞ Displays the error list (current errors)

### 3 Acknowledging and rectifying an error

- ☐ Press the **Info (3)** button
- ☐ Follow the instructions to rectify the error
- ☐ After rectifying the error, press the button

## 4 BCE failure

	<b>A T T E N T I O N</b>
	<p><b>Risk of injury</b></p> <p><b>Electric shock from contact with live terminals</b></p> <ul style="list-style-type: none"> <li>• Observe information signs</li> <li>• Before starting work, check that no voltage is present using a voltmeter</li> </ul>

A BCE failure can occur due to a defective fuse, missing power supply or missing connection to the main board.

- Check the voltage supply and fuse
    - ☞ Fuse F16 on the main board
    - ☞ Mains supply of terminal L / PE / N
  - Check LED H6 on the main board
    - ☞ Check CAN bus cable
    - ☞ Replace BCE or cable
- ⇒ [See Electrical manual](#)

## 5 Temporary emergency operation (restart without HW test)

If the error is clearly a result of a defective boiler control board, and the connected component is working correctly, the control unit can be run in temporary emergency mode without a hardware test being performed on the respective component (until the service department steps in).

- Switch to **Manual** operating mode on the control unit
- Switch to the respective manual parameter of the respective component
- Confirm **Without HW test**

☞ Boiler operates with max. 60% output

## 6 Combustion error No. 0029

A combustion error exists when the O2 value is:

- longer than the time set in service parameter No. **S5** and
  - above the percentage set in service parameter No. **S4**
- ☞ No pellets are delivered or ignition failed

### Possible causes:

- Day hopper empty
  - ☞ Defective fill level indicator (incorrect / insufficient suction times set for FEA)
- Bridging inside the day hopper
  - ☞ Foreign object or too much dust inside the day hopper
- Stoker motor runs reverse
  - ☞ Stoker motor defective

The system performs an automatic self test.

- Observe instructions on the display

When the test is finished, the following message is displayed:

**Check ash pan for any unburned pellets inside**

## 6.1 Pellets being delivered

- Clean combustion chamber
- ⇒ See "Cleaning" on page 55.
- Start the system in **Auto** switch selector position
- Check stoker motor (chain drive)
- ☞ If there are phases of reverse rotation, the stoker motor has a malfunction must be replaced as soon as possible

## 6.2 No pellets being delivered

- Check if pellets are in the day hopper

### No pellets in the day hopper

- Check the fill level indicator is working properly (full = light off, empty = light on)
- Refill the day hopper and the stoker auger
- Check the suction times (customer parameter **No. 14**) in the **Auto** selector switch position and set a third or fourth suction time if required (evenly spread throughout the day)

### Pellets available, but not being delivered

(Bridging in the day hopper)

- Pellets are not dropping down due to debris or a high dust deposit in the day hopper
- Unscrew the lid of the day hopper and remove the pellets
- Remove any debris or, if you find dust to be the cause of the problem, you might want to discuss the pellet quality with the pellet supplier
- Refill the day hopper and the stoker auger

### Filling pellets

- Start automatic pellet filling in manual mode **No. 8**
  - ☞ The fill level indicator switches the turbine off automatically
- In manual mode **No. 5**, switch on the stoker auger until pellets begin to drop into the ash pan
- Start the system in **Auto** switch selector position

# Appendix

	<b>NOTE</b>
	<b>Please be advised that we do not accept responsibility for damage or malfunctions resulting from non-observance of the manual.</b>

## 1 Copyright notice

This manual should be kept confidential. The manual is intended solely to be used by authorised persons. The transfer to third parties is prohibited and is liable to compensation. All rights reserved, also translations. No part of this manual may be reproduced or processed, duplicated or distributed using electronic systems without the permission of Hargassner Ges mbH.

### 1.1 Measures prior to commissioning by the operator

Licensing requirements for safe operation and accident prevention regulations must be observed! Work on hydraulic systems must be carried out only by personnel with specialised knowledge and experience in hydraulics.

### 1.2 Liability

This **wood biomass boiler** has been manufactured and tested in accordance with recognised safety regulations and the latest engineering standards, and is therefore safe to operate. However, improper use may cause lethal hazards for the operator or third parties or may damage the unit and other property.

This **wood biomass boiler** must only be used as intended, when it's in technically perfect condition and with safety and danger in mind. Especially errors tending to affect the safety shall be cleared immediately.

Liability for the **wood biomass boiler** functioning correctly will always be borne by the owner or operator if the device has been improperly maintained or repaired by individuals who have not been authorised by Hargassner Ges mbH or has been handled or operated in a manner that does not comply with the device's intended use.

In the interest of the continuous development and improvement of our products, we reserve all rights to make technical changes to the information contained in our printed material.

These kinds of changes, errors and misprints do not constitute grounds for any claims for damages.

Only original Hargassner spare parts and accessories must be used.

In addition to the guidelines in this operation manual, please follow general guidelines for safety and accident prevention. Hargassner Ges mbH is not liable for any damage resulting from failure to observe the instructions and guidelines in this manual. This boiler system's reliability is guaranteed by **Hargassner Ges mbH** vast experience, very modern production methods and extremely high quality standards. **Hargassner Ges mbH cannot** be held liable for safe operation of the **wood biomass boiler** if it has been handled or operated in a manner that does not comply with its intended use.

The customer has NO warranty claims:

- if heating fuel is missing wrong or of poor quality
- if damages occur through incorrect assembly, misuse or lack of maintenance
- if the installation manual and operation manual is NOT observed
- for defects that do not affect the performance of the system. E.g.: Paint defects,....
- for damages arising from force majeure like fire, flooding, lightning stroke, electrical surge, power loss, ...
- if a non-licensed installer or non-licensed plumber installs the product
- for damage caused by air pollution, heavy dust, aggressive vapours, oxygen corrosion (non diffusion-tight plastic tubing), installation in inappropriate rooms (laundry room, hobby room, ...) or continued use despite the occurrence of a defect

To ensure repair or maintenance work relating to defects and malfunctions not mentioned in this manual is carried out properly, always contact **Hargassner Ges mbH** beforehand.

The warranty and liability terms in **Hargassner Ges mbH** general terms and conditions will not be extended because of information in this manual.

The **safety instructions** in this manual must be observed. Only use Hargassner replacement parts or equivalent replacement parts that have been approved by **Hargassner Ges mbH**. Constant technical innovations mean that we reserve the right to modify the design of our products and services without notice.

Please make sure you include the **serial number** of your **wood biomass boiler** in any queries.

We wish you all the best with this **wood biomass boiler** from Hargassner.



# Declaration of Conformity

**HARGASSNER**  
HEIZTECHNIK DER ZUKUNFT



Manufacturer:	<b>HARGASSNER Ges mbH</b> <b>Anton Hargassner Straße 1</b> <b>4952 Weng</b> <b>AUSTRIA</b>  The manufacturer is also the party authorised to compile the technical documentation
Type of machine:	<b>Boiler for solid fuels with automatic loading</b>
Type:	<b>PELLET BOILERS</b> <b>Nano-PK 6-15</b> <b>Optional fuel extraction system available RAS 150-800, RAPS, PWB(N), AUP</b>
Standard:	<b>from 01.10.2017</b>
Directives:	<p>The manufacturer hereby declares that the products mentioned above comply with the regulations laid down in the following European directives:</p> <ul style="list-style-type: none"><li>• Machinery Directive 2006/42/EC</li><li>• Low Voltage Directive 2014/35/EU</li><li>• EMC Directive 2014/30/EU</li><li>• Ecodesign directive 2009/125/EG</li><li>• Ecodesign directive (EU) 2015/1189</li></ul>
Standards:	<p>Conformity with the guidelines is verified through the manufacturer's compliance with the relevant requirements, which are laid down in the following standards among other places:</p> <ul style="list-style-type: none"><li>• EN 303-5:2021 Heating boilers for solid fuels, manually and automatically stoked, nominal heat output of up to 500 kW</li><li>• EN ISO 12100:2010 Safety of machinery - General principles for design - Risk assessment and risk reduction</li><li>• ÖNORM EN 60335-2-102:2016 Household and similar electrical appliances - Safety - Particular requirements for gas, oil and solid-fuel burning appliances having electrical connections</li></ul>
Place, date:	Weng, 08.06.2021
Name:	Dr. Johann Gruber
Signature:	
Function:	Head of Development

---

**notes**

---

notes

---

**notes**

Your expert for **PELLET** | **WOOD LOG** | **WOOD CHIP** HEATING

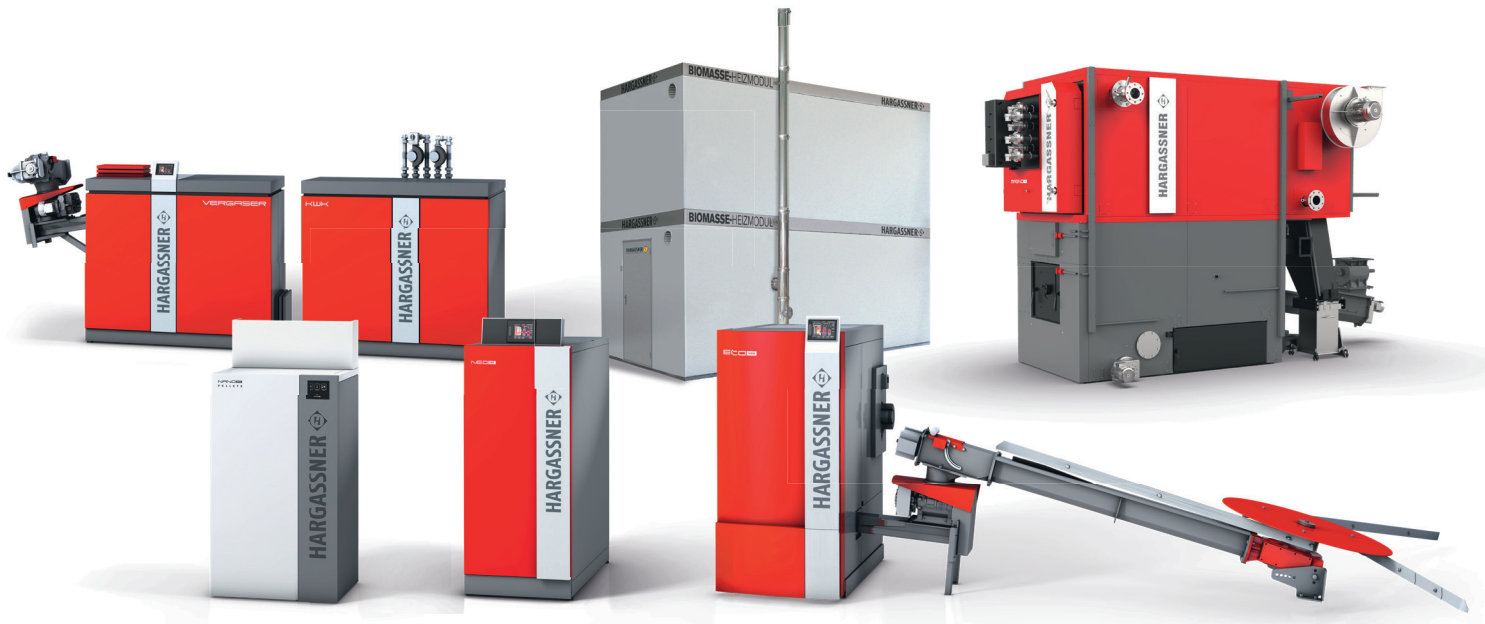
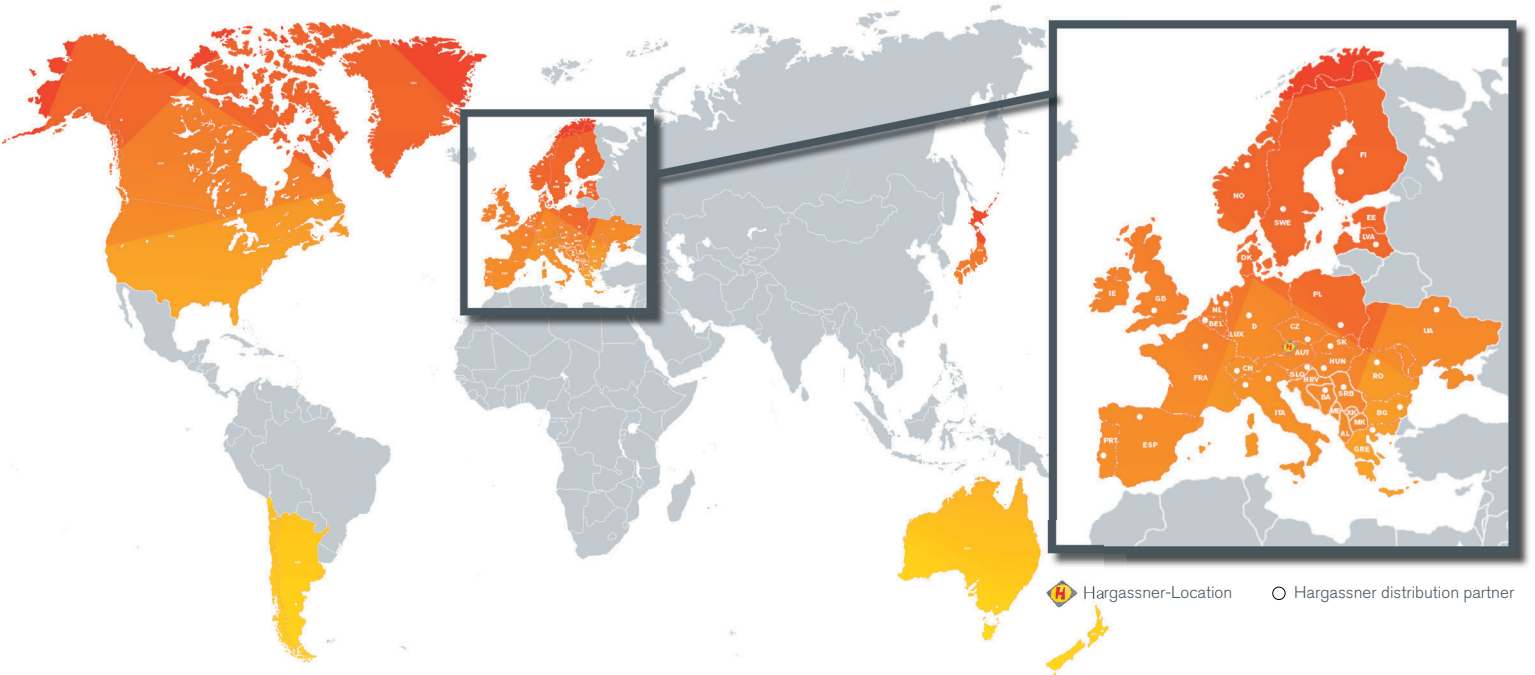

[hargassner.com](http://hargassner.com)

#### AUSTRIA

**HARGASSNER Ges mbH**  
Anton Hargassner Strasse 1  
A-4952 Weng  
Tel. +43 (0) 77 23 / 52 74  
Fax +43 (0) 77 23 / 52 74 - 5  
[office@hargassner.at](mailto:office@hargassner.at)

#### GERMANY

**HARGASSNER DE GmbH**  
Heraklithstraße 10a  
D-84359 Simbach/Inn  
Tel. +43 (0) 77 23 / 52 74  
Fax +43 (0) 77 23 / 52 74 - 5