

Installation manual Pellet Boiler Eco-PK 70-120

HARGASSNER
HEIZTECHNIK DER ZUKUNFT



Follow and store this manual

HARGASSNER Ges mbH

A 4952 Weng, Upper Austria
Tel.: +43/7723/5274-0
Fax: +43/7723/5274-5
office@hargassner.at
www.hargassner.com

EN - V06 02/2022 - 11059744

Contents

1 General	4
2 Transport	5
2.1 Transport weight	5
2.2 Place of installation	5
2.3 Space requirements of the boiler, operating area	5
3 Installation dimensions	6
3.1 Space requirements	6
3.2 Dimensioning	7
3.3 Connections	8
3.4 Technical Data	9
4 Scope of delivery overview	10
5 Unloading the system	11
6 Setup	12
6.1 Removing the cover door	13
7 Installing the trim panel	14
8 Installing the flue gas exhaust fan motor	14
9 Fitting the levelling feet	14
10 Installing the stoker unit	15
10.1 Installing the pellet day hopper	16
11 Mounting instructions for pellet hoses and pellet steel pipes .	17
11.1 Earthing of pellet hoses and pellet steel pipes	17
11.2 Labelling of pellet hoses	18
11.3 Laying pellet hoses	20
11.4 Laying pellet steel pipes	22
11.5 Accessories for pellet hoses and pellet steel pipes	24
12 Ash box	25
12.1 Installing the ash box flange	25
12.2 Installing the ash box (30 litres)	26
12.3 Installing the ash box (60 litres)	27
13 Design of the fuel storage room	29
13.1 Pellet storage room ventilation	29
13.2 Safety in the fuel storage room	30
14 Facilities on site	31
14.1 Country-specific regulations	31
14.2 Qualification of installation staff	31
14.3 Fire extinguisher	31
14.4 Designs of the boiler room	32
14.5 Ventilation of the boiler room	33
14.6 Flue connection, flue pipe	33
14.7 Flue draught stabiliser	34
15 Hydraulic installations	34

15.1 Back-end protection unit	35
15.2 Domestic hot water mixer	36
15.3 Safety group	36
16 Electrical installations	37
16.1 Installing the main power switch	38
16.2 Cable installation	38
17 Sensor installation	39
17.1 Outdoor sensor	39
17.2 Flow, accumulator and external heat sensors	39
18 Remote control FR25 / FR35 / FR40	41
18.1 FR25 remote control (analogue)	41
18.2 FR35 remote control (digital)	41
18.3 FR40 remote control (digital)	41
19 Extension module, board or controller	42
19.1 Extension module 0, 1, 2	42
19.2 Additional board I/O 36 (HC AB/F, 5-sensor accumulator or differential controller)	42
19.3 Heat circuit controller HKR	42
20 Permits and reporting requirements	42
21 Commissioning the boiler	42

1 General

This installation manual is part of the system's operating manual.

	D A N G E R
	<p>Danger to life Non-observance of the safety instructions may lead to death, injuries and damage</p> <ul style="list-style-type: none">• Observe safety instructions attached to the system and in the manual• The activities described may only be carried out by trained assembly personnel of Hargassner

	D A N G E R
	<p>Danger to life Risk of death, injuries, damage due to incorrect design of the boiler room and fuel storage room</p> <p>Boiler room</p> <ul style="list-style-type: none">• Execution according to the local fire protection regulations• Ensure fire-safe, level and firm floor condition• Ensure there is a sufficient supply of combustion air that meets local regulations• Ensure weatherproof and frost-proof design• Observe the load-bearing capacity of the foundations<ul style="list-style-type: none">☞ Weight of the system <p>Fuel storage room</p> <ul style="list-style-type: none">• Observe static requirements<ul style="list-style-type: none">☞ Weight of the quantity of fuel stored• Ensure easy access and easy refill of the fuel storage room• Check for frost-proof execution of the boiler room• Maximum ambient temperature 35 °C• Install safety devices in accordance with local regulations• Attach safety instructions near the access

2 Transport

2.1 Transport weight

The boiler is delivered on pallets in individually packaged units.

Designation	Eco-PK 70-90	Eco-PK 100-120
Pallet with boiler depending on version	Approx. 865 kg	Approx. 890 kg
Pallet with stoker unit and day hopper	max. 300 kg	

Unloading, inspection and damage report

- Unload boiler
- Remove packaging
- Dispose of packaging in accordance with the Waste Disposal Act
 - ☞ Recycling materials can be recycled in a separated and cleaned state
- Check the boiler for transport damage
- Check that the delivery is complete
 - ⇒ See "Scope of delivery overview" on page 10.
 - ☞ Record any incompleteness of the delivery immediately in writing and send a report to Hargassner Ges mbH
 - ☞ Record any transport damage immediately in writing, take photographs and send a report to Hargassner Ges mbH
 - ☞ If the transport company is at fault, the complaint must also be noted on the shipping documents

2.2 Place of installation

⇒ See "Designs of the boiler room" on page 32.

Conditions

- Sufficient light
- Ensure fireproof, level and solid floor and ceiling construction
- Free of disturbing electrical installations and pipes

2.3 Space requirements of the boiler, operating area

- See data sheet or individual customer drawing
- Observe minimum distances and space requirements
- Drawing of the installation dimensions
- Leave a gap of 600 mm for access to the chimney

Designation	Eco-PK 70-90	Eco-PK 100-120
Room height	min. 220 cm	min. 220 cm

3 Installation dimensions

3.1 Space requirements

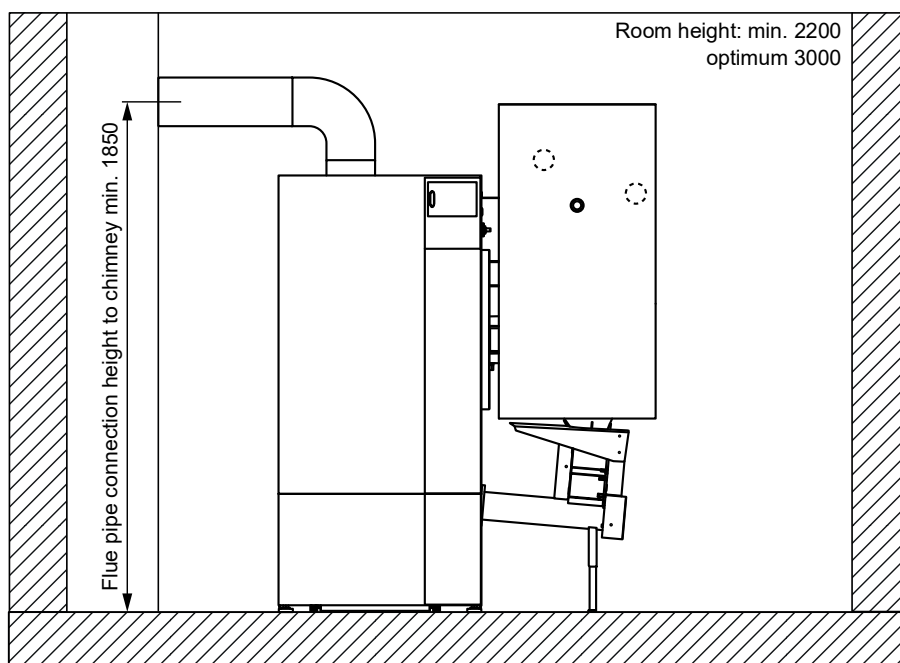
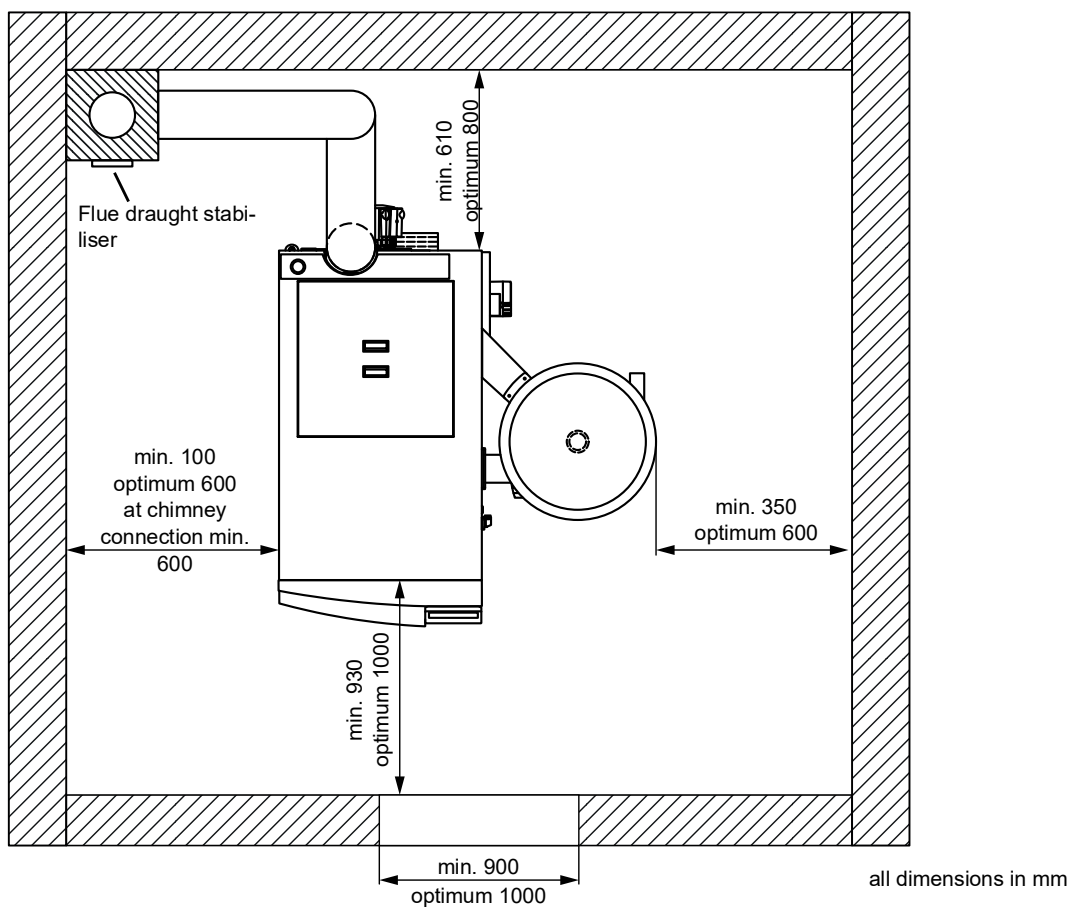

3.2 Dimensioning

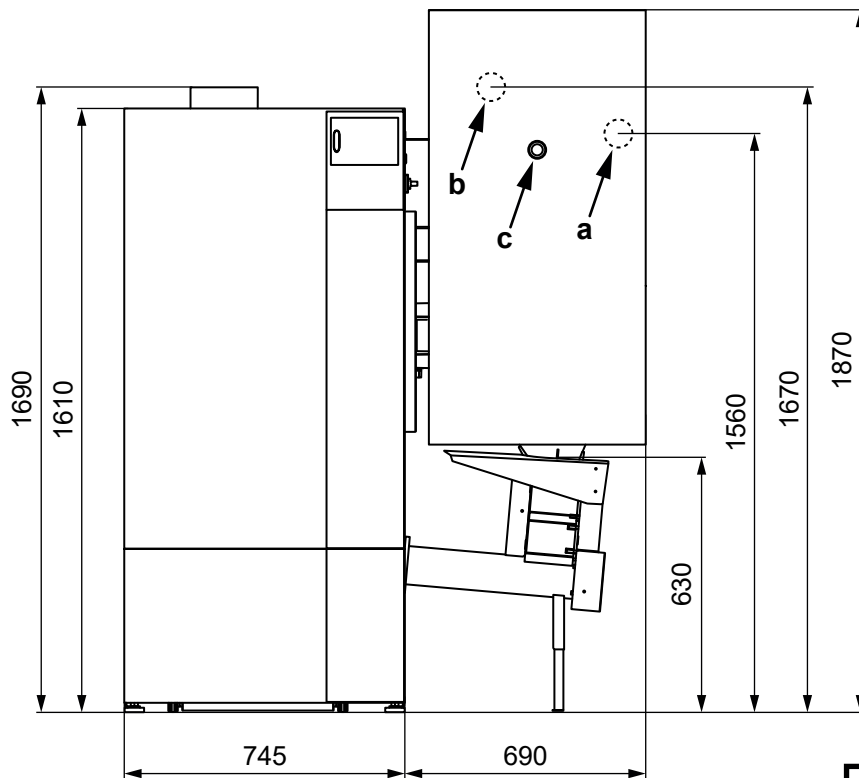

a	Pellet suction hose
b	Return air
c	Fill level indicator

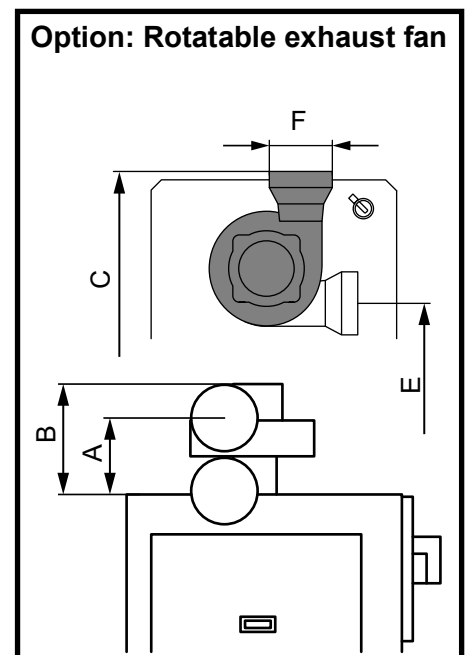
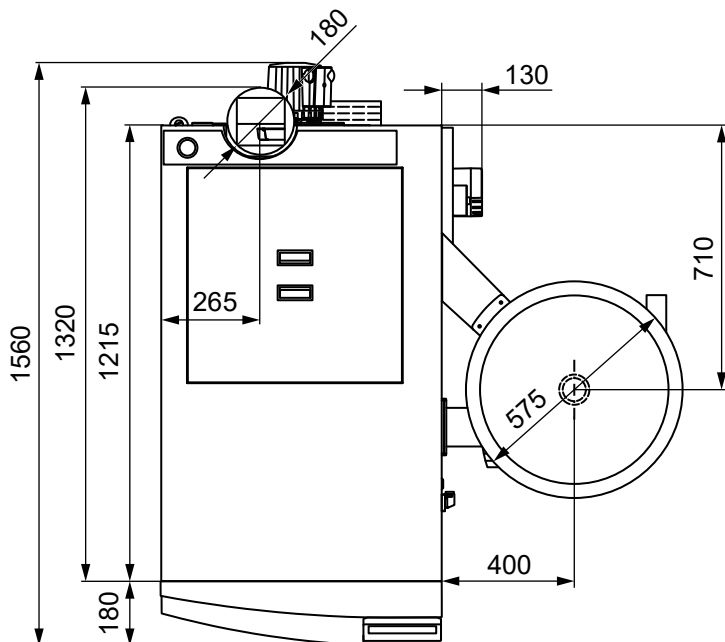

	A	B	C	E	F
Eco-PK 70-120	205	295	1655	1260	Ø180

3.3 Connections

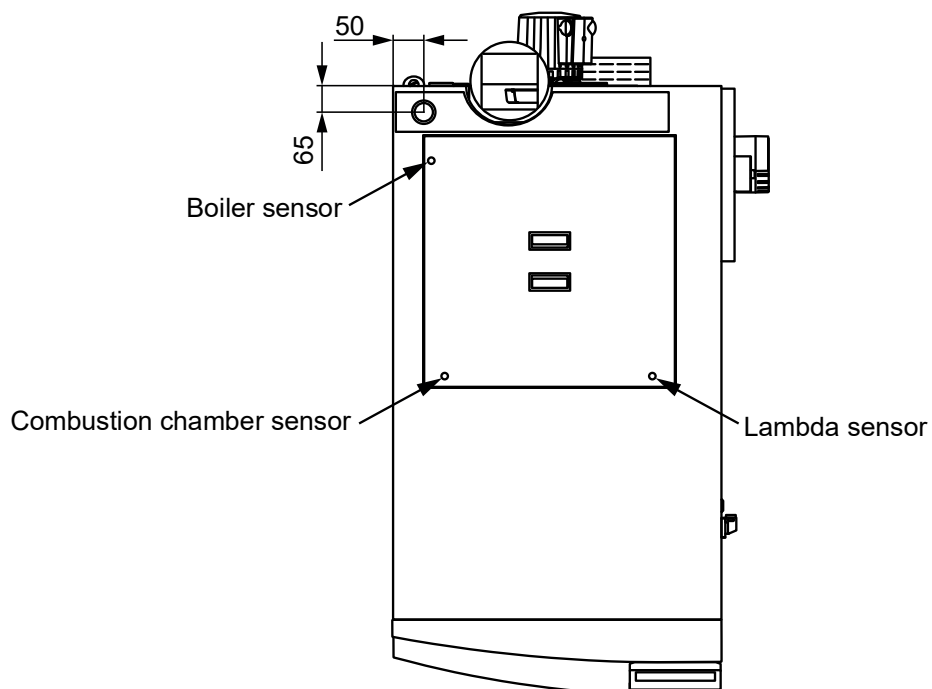
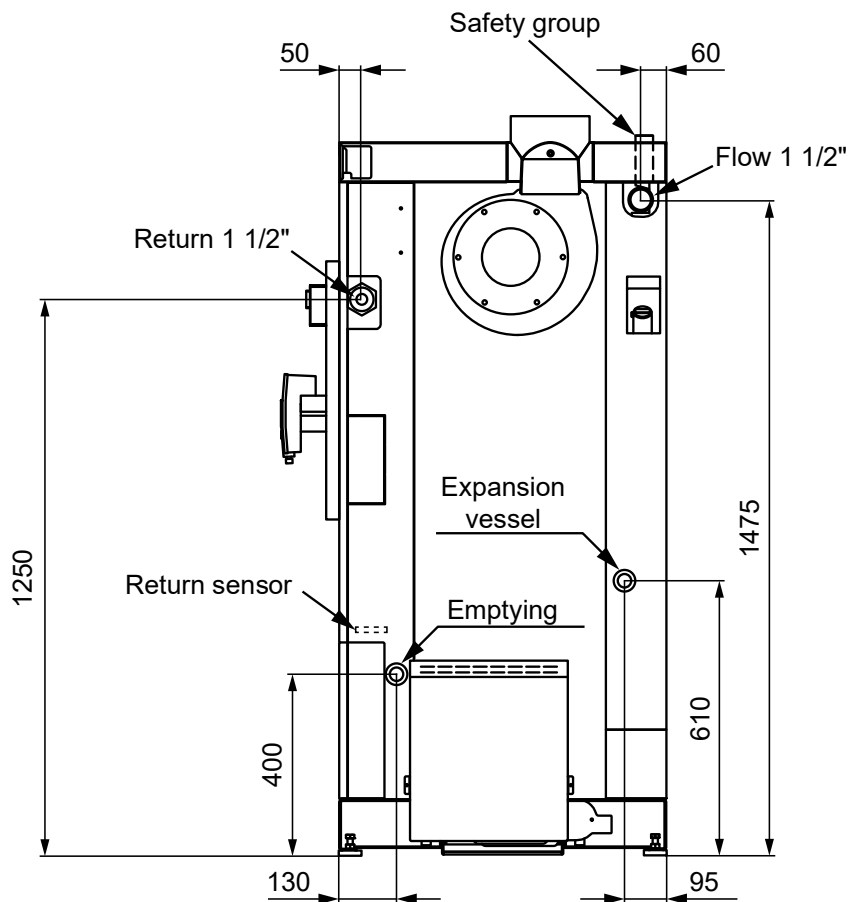

3.4 Technical Data

Designation	Unit	Eco-PK 70	Eco-PK 90	Eco-PK 100	Eco-PK 110	Eco-PK 120
Nominal heating output	kW	21-70	27-90	29.7-99	32.4-108	36-120
Fuel heat output	KW	74	95.6	105.5	115.4	128.6
Boiler class (ÖNORM EN303-5:2012)		5				
Fuel and fuel classification (EN ISO 17225)		Wood pellets (A1)				
Boiler height	mm	1690				
Boiler width	mm	745				
Boiler depth	mm	1560				
Transport dimensions (H / W / D)	mm	1690 / 745 / 1320				
FL connection height	mm	1475				
RL connection height	mm	1250				
Emptying	inches	3/4 IT				
Flow	inches	1 1/2 IT				
Return	inches	1 1/2 IT				
Expansion vessel connection	inches	3/4 IT				
Safety valve connection	inches	1 IT				
Permissible operating pressure	bar	3				
Max. operating temperature	°C	85				
Water content	litres	180				
Weight	kg	865			890	
Req. delivery pressure	Pa	2				
Flue draft max. limit	Pa	10				
Flue pipe diameter	mm	180				
Flue gas temperature	°C	140	150	140	150	160
CO ₂	%	14				
Mass flow rate	kg/sec	0.0389	0.0503	0.0555	0.0607	0.0677
Water-side resistance dT 10°	mbar	57.1	94.4	112.4	133.7	165.1
Water-side resistance dT 20°	mbar	14.6	24.1	28.7	34.1	42.1
Power consumption	W	191				
Electric supply		400V AC, 50 Hz, 13 A				

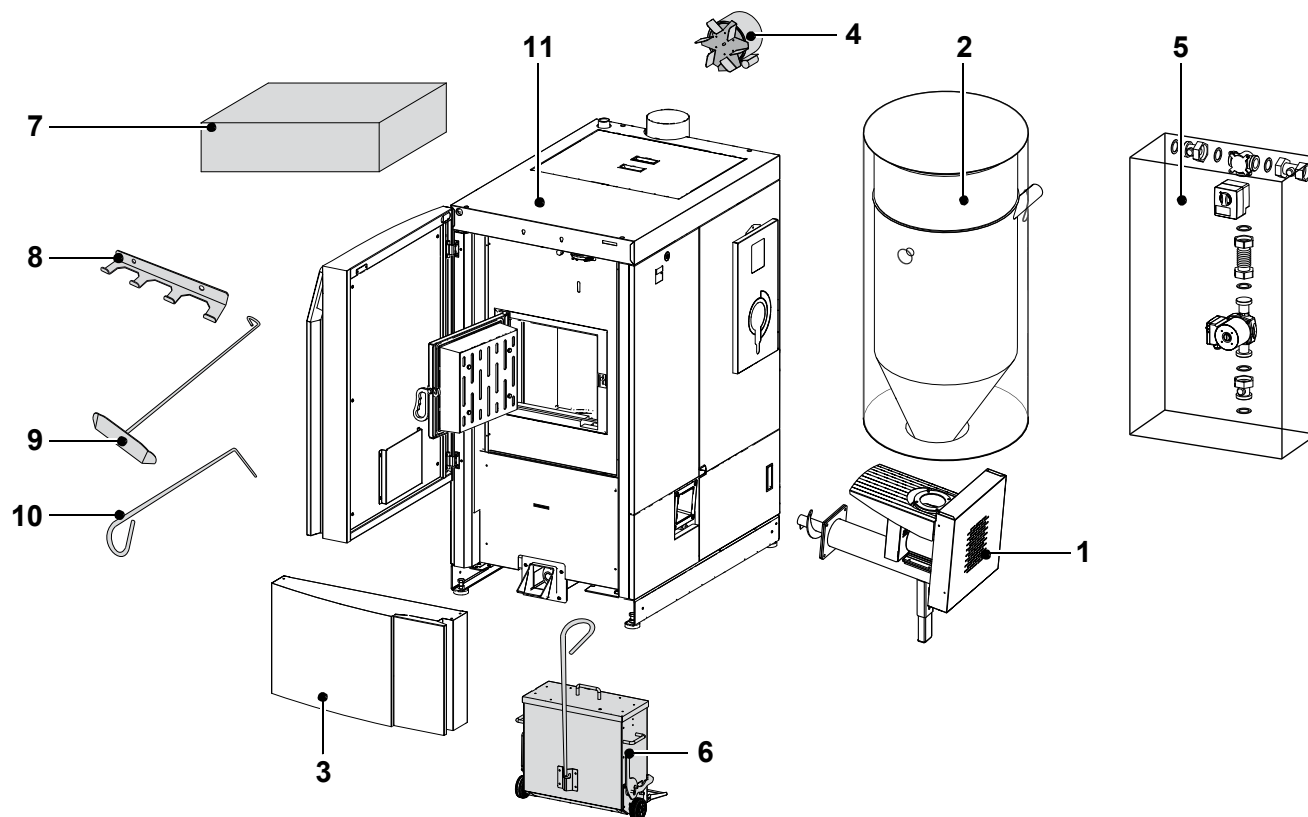

4 Scope of delivery overview

The add-on parts are packaged individually and can be found in the boiler or on the pallets.



Item	Description	Function
1	Stoker unit	Carries the fuel into the combustion chamber ⇒ See "Installing the stoker unit" on page 15.
2	Day hopper	Carries the fuel from the storage room to the stoker unit ⇒ See "Installing the pellet day hopper" on page 16.
3	Trim panel	Lower part of the cover door ⇒ See "Installing the trim panel" on page 14.
4	Exhaust fan motor	Transports the flue gas from the boiler unit into the chimney ⇒ See "Installing the flue gas exhaust fan motor" on page 14.
5	Back-end protection unit (optional)	Adjusts to a constant return temperature ⇒ See "Back-end protection unit" on page 35.
6	Ash box	For collecting the ash from the combustion process ⇒ See "Ash box" on page 25.
7	Sensor package	Flow sensor, return sensor, safety temperature breaker (STB), thermostat, flue gas sensor, lambda sensor, etc., according to sensor plan
8	Flue tool set holder	Wall holder for the flue tool set
9	Ash slider	For cleaning the boiler
10	Poker	For cleaning the combustion chamber
11	Main power switch	On/Off switch for providing power to the boiler ⇒ See "Installing the main power switch" on page 38.

5 Unloading the system

D A N G E R	
 	<p>Risk of death, injuries, damage due to falling or toppling loads</p> <ul style="list-style-type: none">• The system may only be set up by trained staff• Only use tested lifting gear that has a sufficient load-bearing capacity and is in perfect condition• Do not exceed the maximum permissible load (load-bearing capacity) of the forklift or lift truck, note the type plate• Never use bearing bolts, spindles, shaft ends or moving parts as attachment points to hoist the system or system parts• Make sure that nobody stands under suspended loads• At first, only lift the system minimally from the ground<ul style="list-style-type: none">☞ Check that the load attaching points are chosen correctly and are secure☞ The load may only be transported over longer distances once it has been picked up correctly• Pay attention to the centre of gravity<ul style="list-style-type: none">☞ The load pick-up point is not above the centre of gravity☞ Secure against tipping• When lifting the system during transport with a forklift/lift truck, only lift it far enough off the ground for it to be transported safely• Set up the system on an even, horizontal place

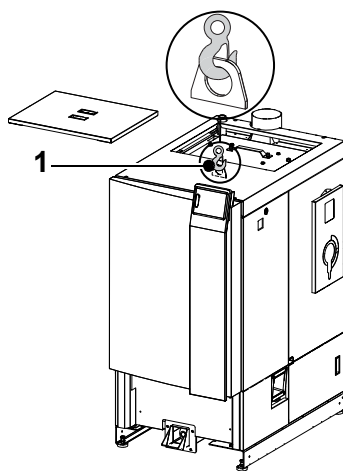

- Remove the cover lid from the system
- Attach the hoist (hook) to the transport lug (1)
 - ☞ Be aware of the risk of tipping during lifting
 - ☞ The load pick-up point is not above the centre of gravity

6 Setup

There are several ways to transport the system to the boiler room

	NOTE
	To transport the boiler safely when moving it to its position Do not remove the pallet from the system during positioning

☞ Recommendation: Use at least four people to move the system into position

Transporting the system on rollers

☞ For better rolling, use at least 1" pipes or equivalent

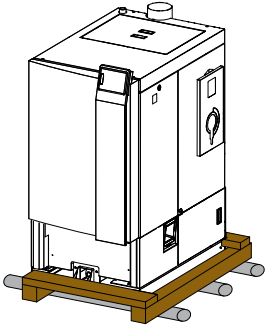

Transporting the system with a lift truck or forklift

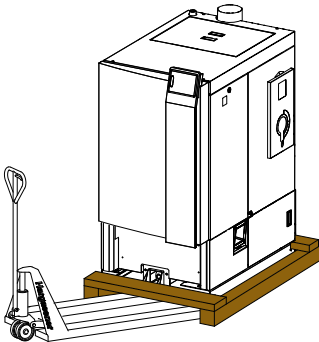

- Position the system in the place provided for this purpose
- Remove the transport timbers from the system

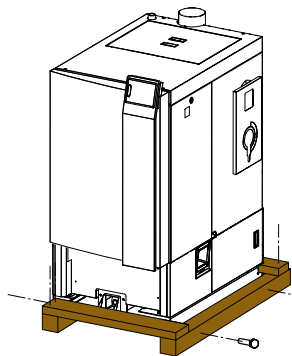

	NOTE
	If space is tight during installation, remove the cover door.

☞ Use at least two people to reduce the transport size.

6.1 Removing the cover door

6.1.1 Removing the control unit (BCE)



- Slide the control unit **upwards** until the bottom disengages from the cover

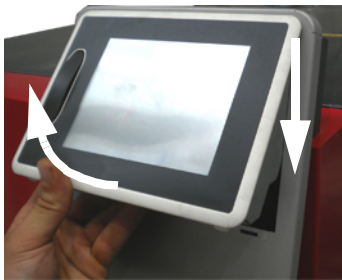

- Tip the control unit out and pull it downwards out of the cover

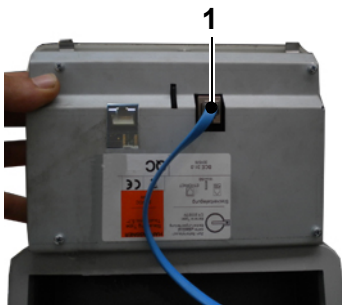

- Disconnect the BUS connection (**1**) from the back of the control unit

- Pull the blue ribbon cable out of the cover door

- Put the control unit safely aside

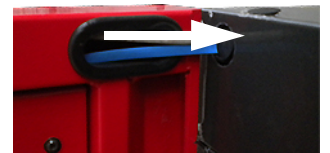

6.1.2 Detaching the cover door



- Pull the bottom hinge pin first and then the top hinge pin (**2**) up and out of the hinge

-  Secure the door against tipping

- Remove the cover door and put it safely aside

- After having positioned the system, install the cover door in reverse order

- Hang up the door

- Pull in the BUS cable

- Install the control unit

7 Installing the trim panel

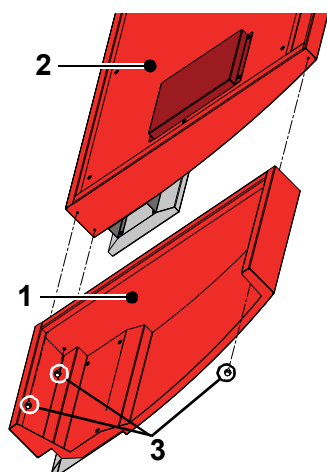

- Position trim panel (1) flush with cover door (2)
- Screw it on with three M6x10 screws (3)

8 Installing the flue gas exhaust fan motor

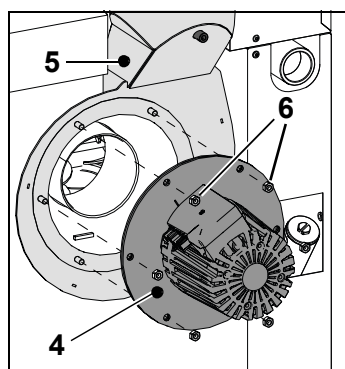

- Attach the flue gas exhaust fan motor (4) to the flue gas exhaust fan housing (5)
- Secure the motor with M8 copper nuts (6)
- Do not damage the seals on the motor and housing

9 Fitting the levelling feet

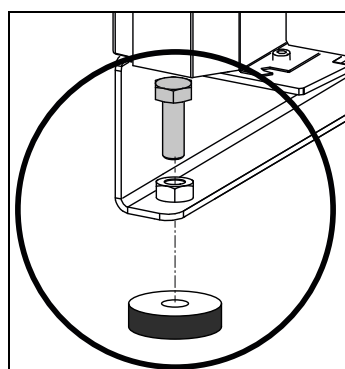

- Once the system is in its final position, it needs to be levelled using the levelling feet.
- Screw the M12x40 screws from the top into the boiler body
 - Position the levelling feet under the screws
 - Lower the system onto the levelling feet
 - Align the system horizontally using the screws

10 Installing the stoker unit

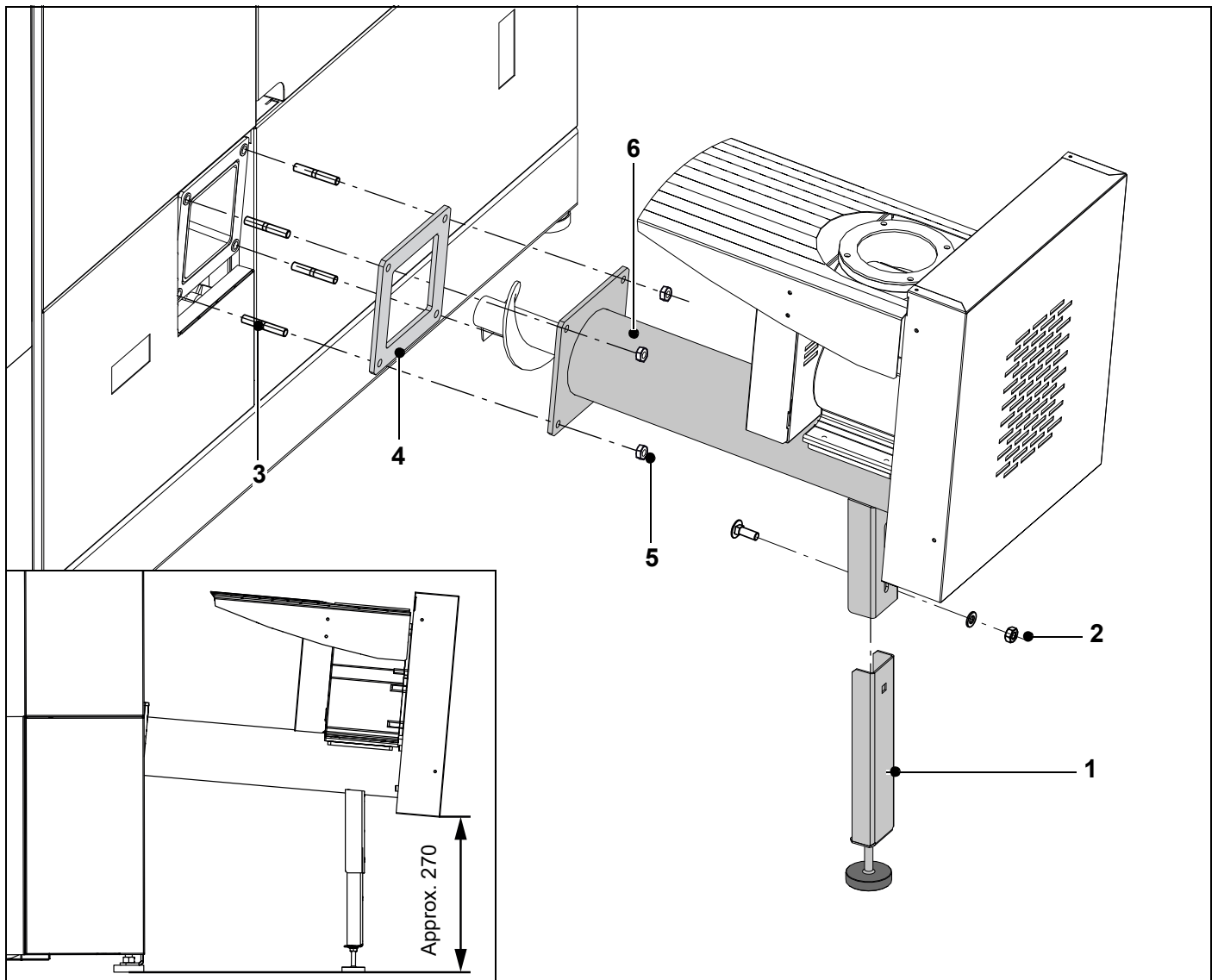

- Put the levelling foot **(1)** in position and secure in place
 - ☞ Position them according to the height
 - ☞ Distance to the floor (when the base is level): 270 mm
 - ☞ M8x20 mushroom head bolts, M8 washers and M8 flange nuts **(2)**
- Screw the **short thread sides** (thread length 10 mm) of 4 M8x20 stud screws (total length 30 mm) **(3)** into the boiler flange
- Insert the seal **(4)**
- Secure the stoker unit **(6)** to the boiler flange
 - ☞ 4 M8 lock nuts **(5)**

10.1 Installing the pellet day hopper

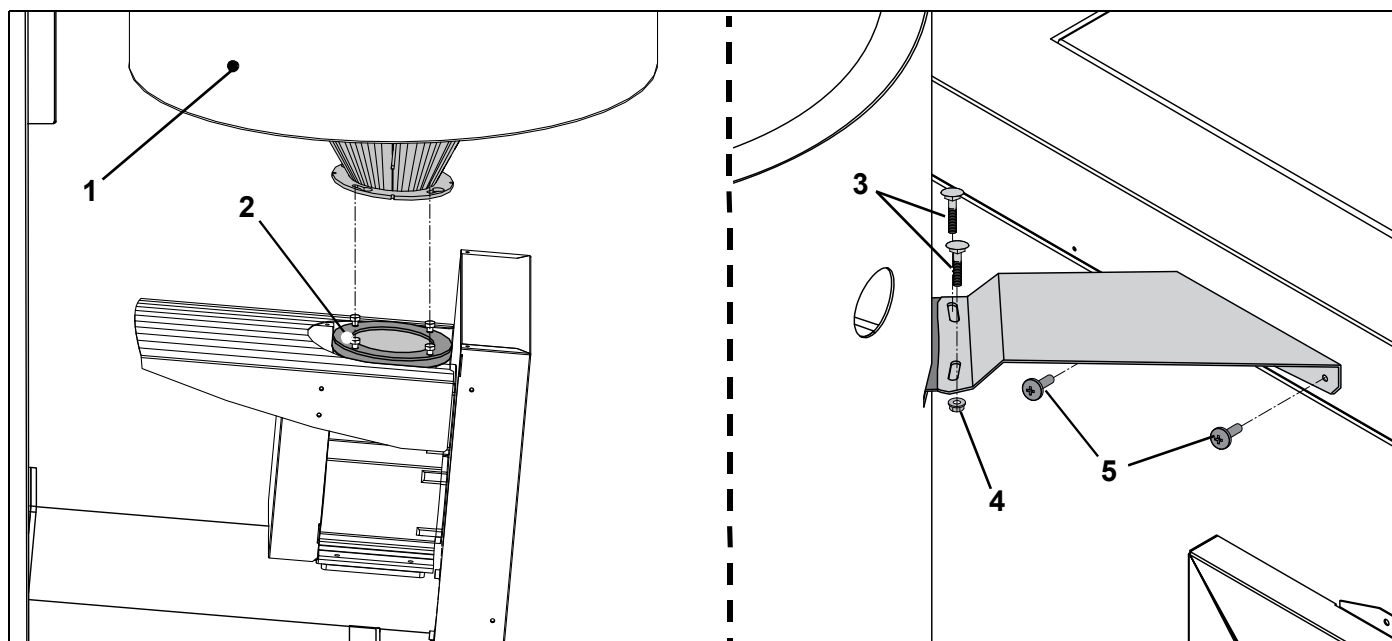

- ❑ Position the pellet day hopper (1) on the stoker unit and secure it (2)
 - ☞ Move the day hopper into position by twisting it and secure it with M6x10 screws (2)
- ❑ Attach the day hopper support plate to the day hopper using M6x10 mushroom head bolts (3) and M6 nuts (4)
- ❑ Secure the day hopper support plate to the boiler using M4x12 self-tapping screws (5)

11 Mounting instructions for pellet hoses and pellet steel pipes

A T T E N T I O N	
	<p>Damage to the system due to incorrect laying of the pellet hoses</p> <ul style="list-style-type: none">• Do not kink hoses<ul style="list-style-type: none">⇒ See "Laying pellet hoses" on page 20.• Hose temperature resistance: Minimum -5°C, maximum 60°C<ul style="list-style-type: none">☞ Do not allow the hoses to touch non-insulated heating pipes☞ Minimum distance to non-insulated flue gas pipes: 20 cm• Do not install hoses outside in an unprotected condition<ul style="list-style-type: none">☞ Hoses are not UV-resistant• Note direction arrows (air and pellet hose)<ul style="list-style-type: none">⇒ See "Labelling of pellet hoses" on page 18.• Ensure correct hose routing to overcome different height levels<ul style="list-style-type: none">⇒ See "Pellet hose laying diagram/overcoming the height difference" on page 21.• Only use a single-piece pellet suction hose<ul style="list-style-type: none">⇒ See "Extending the pellet hoses" on page 24.• Pellet hoses are wear parts<ul style="list-style-type: none">☞ Lay the hoses so that they are easily accessible for replacement in the event of wear

11.1 Earthing of pellet hoses and pellet steel pipes

W A R N I N G	
	<p>Risk of fire due to electro-static discharge</p> <p>Earthing of pellet hoses</p> <ul style="list-style-type: none">• Earth the pellet hoses at both ends with the copper wire inside the hoses• Use nozzles made of metal<ul style="list-style-type: none">☞ When extending the return air hose☞ Remove any existing paint (blank surface)

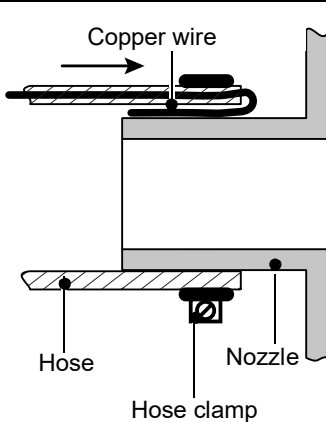



Pellet transport in the hoses causes electrostatic charge.

- Earth the pellet suction hose and return air hose at each fixation to the nozzle (on both ends)
- Pull the copper wire out of the hose and strip approx. 5 cm of the insulation
- Clamp the copper wire between the nozzle and hose
- Insert the hose over the nozzle
- Secure the hose to the nozzle using the hose clamp

Earthing with pellet steel pipes

- Bend the wire bracket of the insertion coupling inwards

11.2 Labelling of pellet hoses

	A T T E N T I O N
	Damage to the system due to incorrect connection of the pellet hoses <ul style="list-style-type: none">• Connect the pellet hoses according to the direction arrows on the hose nozzle
	N O T E
	Labelling hoses <ul style="list-style-type: none">• Label the pellet suction hose and return air hose permanently on their respective ends so that they cannot be mixed up<ul style="list-style-type: none">☞ This prevents confusion during assembly or maintenance work

11.2.1 Point extraction RAPS

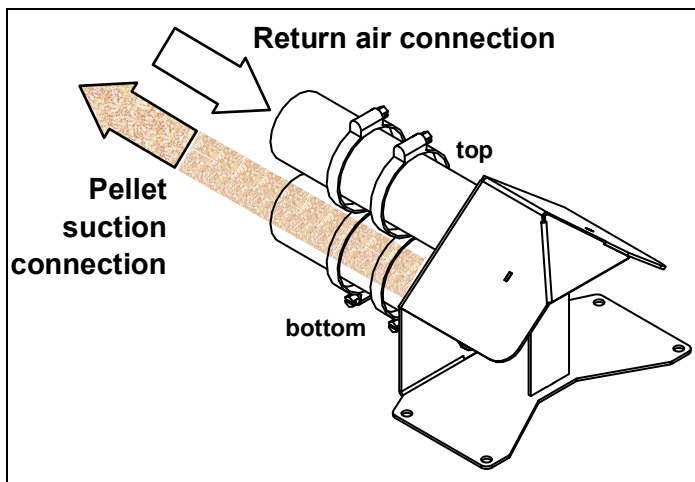

11.2.2 Fuel extraction auger RAS

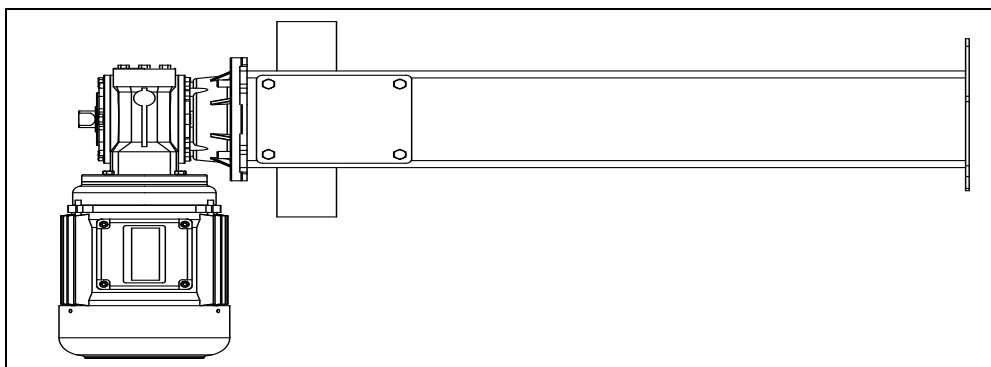

- Connect the pellet hose either on the left or the right nozzle depending on the available space

11.2.3 Bag silo GWTS / GWT-MAX

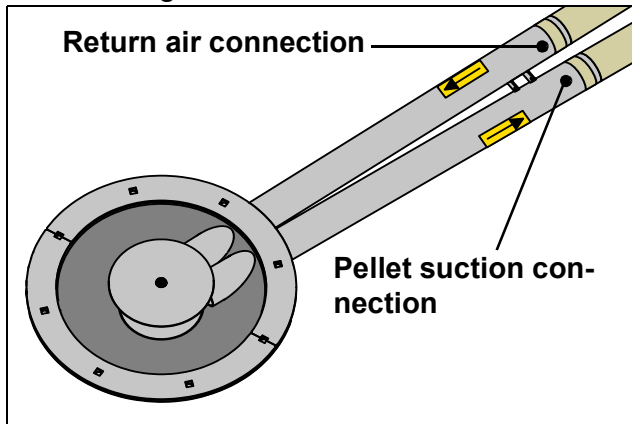

11.2.4 Pellets weekly tank PWB and underground pellet tank

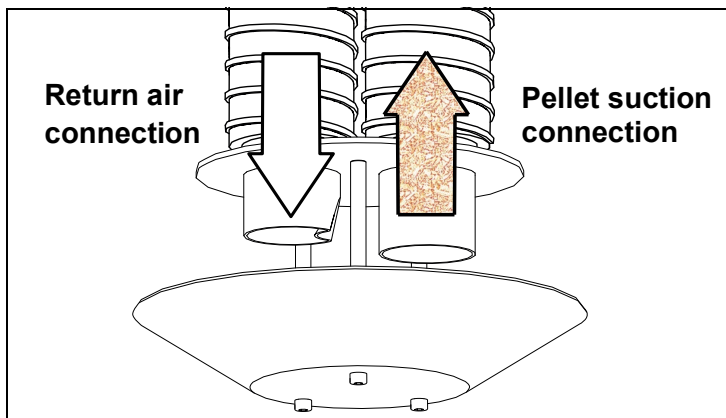

11.2.5 Changeover unit AUP

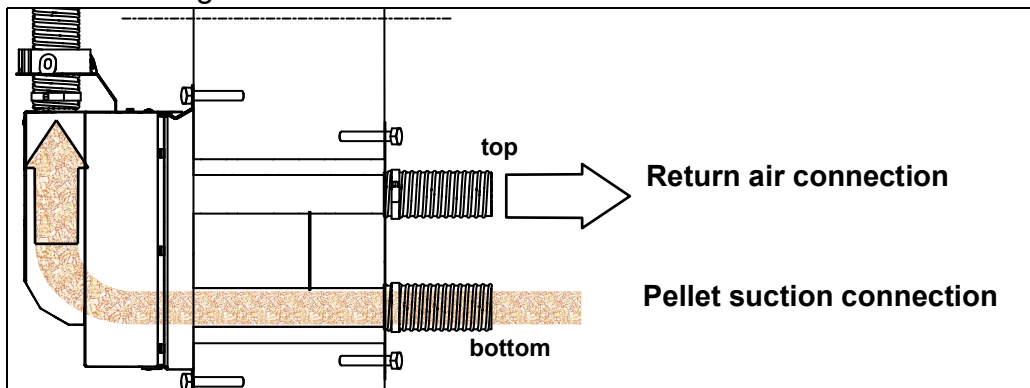

11.2.6 Pellet container on the system

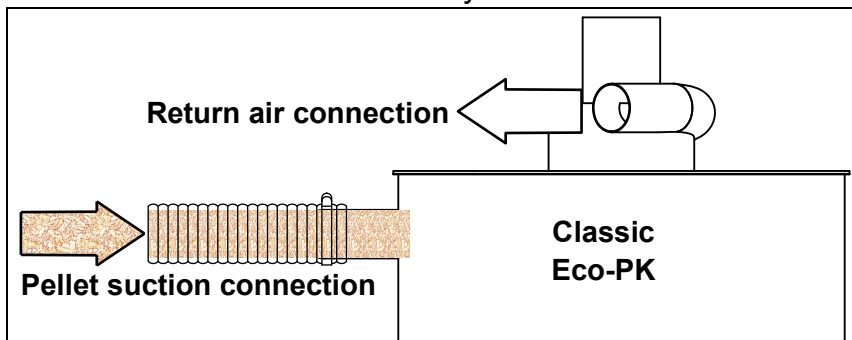

11.3 Laying pellet hoses

11.3.1 Laying the pellet suction hose

	A T T E N T I O N
	Risk of blockage and abrasion by pellets during suction <ul style="list-style-type: none">• change direction with 90° steel pipe bends• Secure hoses against shifting using pipe clamps

Pellet boilers from 70 kW

- Always install pellet suction hoses perfectly straight
- Only use 90° steel pipe bends to change direction

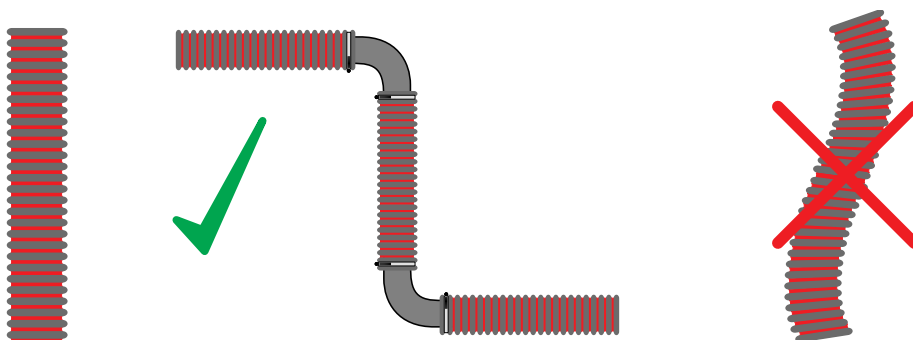

Recommendation: From a boiler output of 130 kW, the pellet suction line should be made entirely of steel pipes.

⇒ [See "11.4 Laying pellet steel pipes" on page 22.](#)

11.3.2 Laying the return air hose

- Make sure the laying radius is at least 30 cm
 - ☞ Use the enclosed gauge to check this

11.3.3 Pellet hose laying diagram/overcoming the height difference

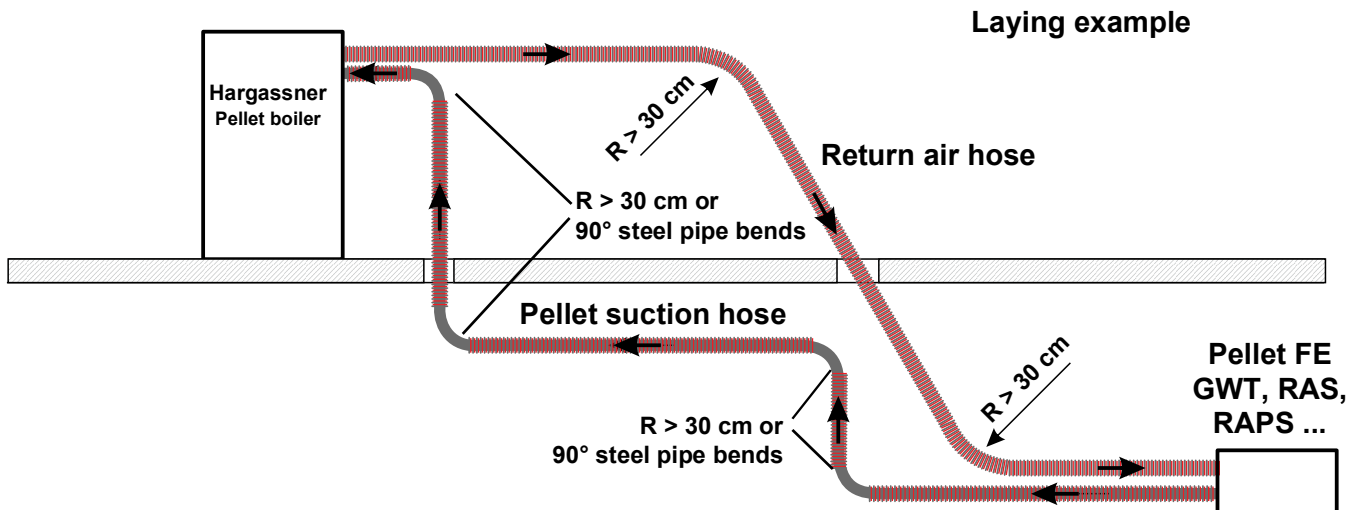

- ☞ The suction turbine is designed to suction the pellets over a length of 20 m with pellet hoses and a height difference of 5 m
- ☞ A maximum of six 90° steel pipe bends can be used for a suction distance of 20 m
- ☞ When using a fuel extraction system RAS, the suction line can be up to 30 m long if the transport auger is cycled in the service settings. For longer or higher transport routes, always contact Hargassner Ges mbH
- ☞ When using point suction systems (RAPS, GWT), the pellets fall back down into the suction hose when the suction turbine stops. These pellets that fall back can block the pellet hose. To avoid this, install horizontal sections to overcome the height difference
- ☞ Use mounting clamps or support shells for better routing of the pellet hoses
 - ⇒ See "Wall fixing elements" on page 24.

11.3.4 Do not loop the pellet suction hoses



- Do not form loops (bags) in the hoses during laying
 - ☞ Pellets that fall back can block the suction hose

11.4 Laying pellet steel pipes

- ☞ For AUP and GWTS/GWT-MAX, the last metre of the pellet steel pipe for connecting to the fuel extraction system must be made with a flexible pellet hose
- ☞ Vibrations and small movements of the fuel extraction system can be better absorbed by flexible hoses

11.4.1 Screw connection of the pellet steel pipes

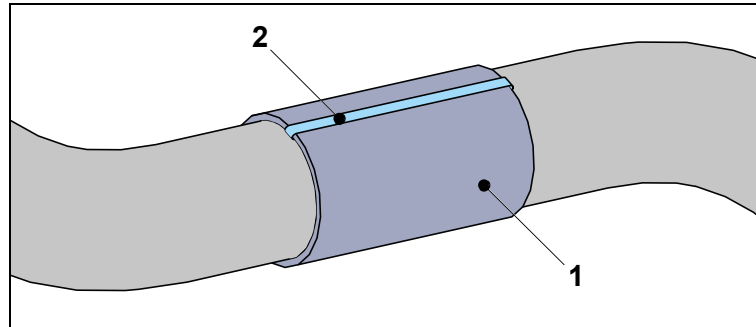

- ☐ Connect both pellet steel pipe elements and position the collar (1) over them
- ☐ Bend the wire bracket (2) inwards

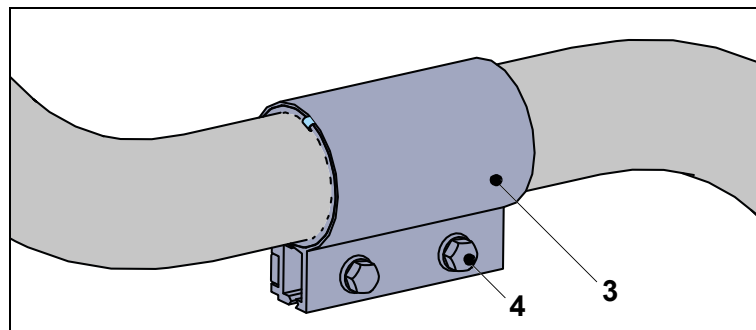

- ☐ Position the pipe coupling (3) over the collar
- ☐ Tighten both screws (4)

11.4.2 Basic set for pellet steel pipes

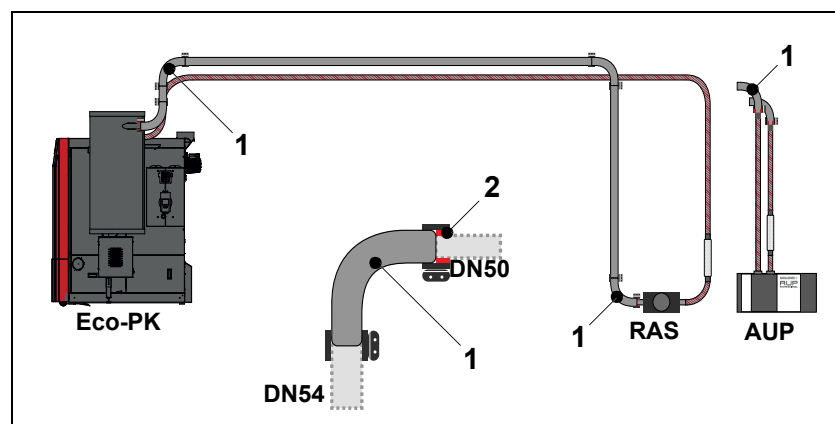

- ☞ Use the basic set (1) when using a pellet container and fuel extraction auger (RAS) or changeover unit (AUP)
- ☞ The insert seal (2) included in the basic set bridges the difference in diameter between the pellet steel pipe, pellet container, RAS or AUP

11.4.3 Pellet steel pipe laying diagram/overcoming the height difference

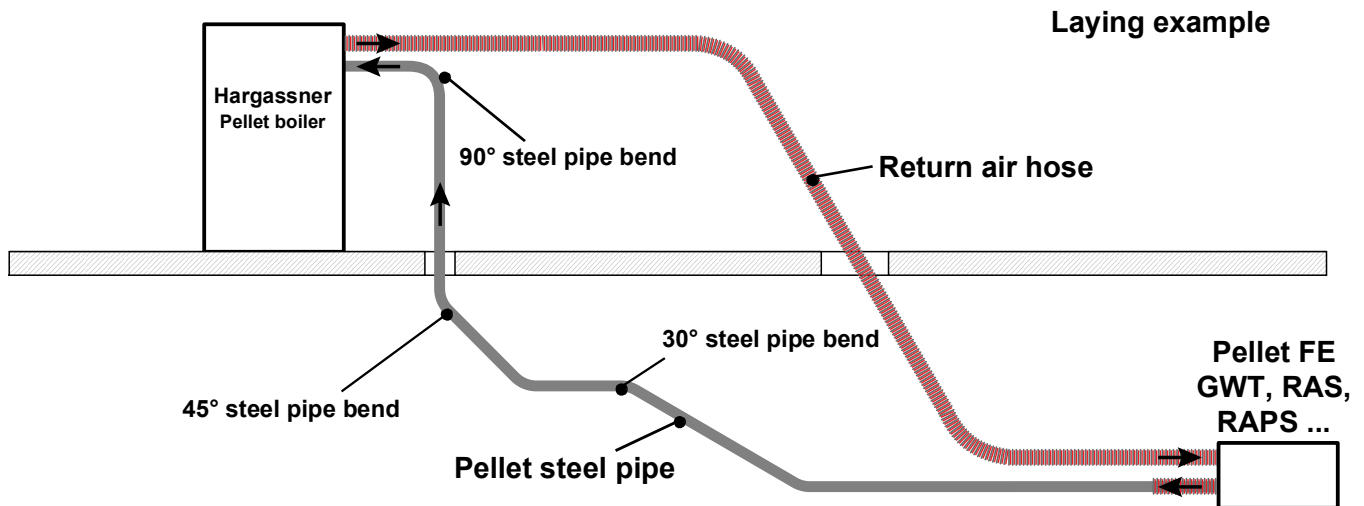

- ☞ The suction turbine is designed to suction the pellets over a length of 30 m with steel pipes and a height difference of 5 m
- ☞ A maximum of six 90° steel pipe bends can be used for a suction distance of 30 m
- ☞ When using a fuel extraction system RAS, the suction line can be up to 30 m long if the transport auger is cycled in the service settings. For longer or higher transport routes, always contact Hargassner Ges mbH
- ☞ When using point suction systems (RAPS, GWT), the pellets fall back down into the suction pipe when the suction turbine stops. These pellets that fall back can block the pellet steel pipe. To avoid this, install horizontal sections to overcome the height difference
- ☞ Use mounting clamps or support shells for better routing of the pellet steel pipes
 - ⇒ See "Wall fixing elements" on page 24.
- ☞ Make the wall breakthroughs in accordance with local fire protection regulations

11.4.4 Do not loop the pellet steel pipes



- ☐ Do not form loops (bags) in the pipes during laying
- ☞ Pellets that fall back can block the pellet steel pipe

11.5 Accessories for pellet hoses and pellet steel pipes

11.5.1 Extending the pellet hoses

A T T E N T I O N	
	<p>Damage to the system due to incorrect extension of the pellet hoses</p> <p>Do not extend the pellet suction hose</p> <ul style="list-style-type: none">☞ Insufficient pellet transport <p>If necessary, extend the return air hose correctly</p> <ul style="list-style-type: none">• Connect the return air hose segments outside the pellet storage room to provide easy access to their point of assembly• Metal extension pipe• Connect the return air hose earth wire to the extension tube <p>⇒ See "Earthing of pellet hoses and pellet steel pipes" on page 17.</p>

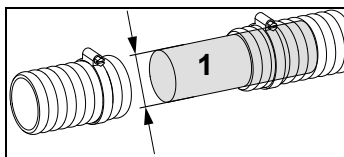

- ☐ To extend the return air hose, insert both hose ends onto a metal tube (1), earth them and secure them with hose clamps

11.5.2 Wall fixing elements

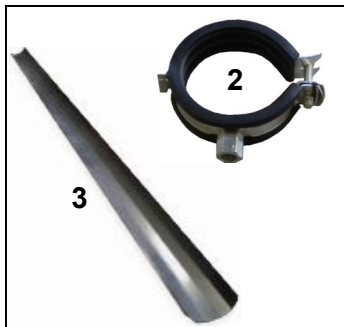

- ☐ Mounting clamps (2) and support shells (3) can be used to easily install the pellet hoses on the wall

11.5.3 Suction hose bend 90°



- ☐ Use the 90° suction hose bend with screw clamps for very tight curves or outward bends
- ☞ Always use 90° steel pipe bends to change direction for pellet suction hoses from a 70 kW system output

11.5.4 Fire protection sleeve for pellet hoses



- ☐ Mount a fire protection sleeve on each pellet hose for each wall breakthrough

12 Ash box

12.1 Installing the ash box flange

1. Open the cover door



2. Correctly position the flange on the boiler



3. Secure the flange using 4 M6x16 hexagon socket screws (in the screw package)



12.2 Installing the ash box (30 litres)

12.2.1 Adjusting the wheels

1.

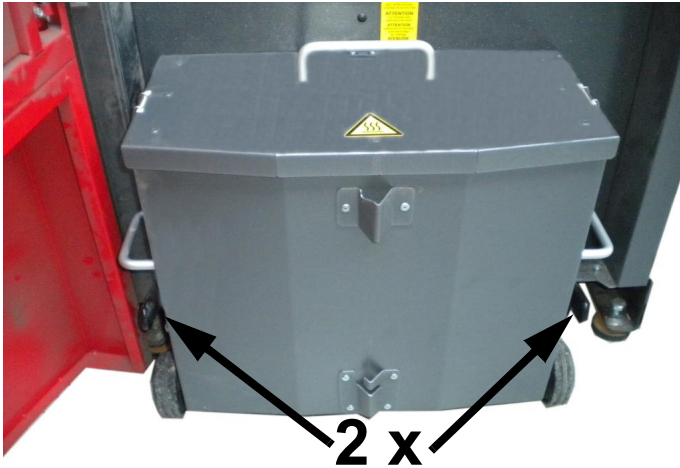

- ☐ Position the ash box on the boiler and lock in place

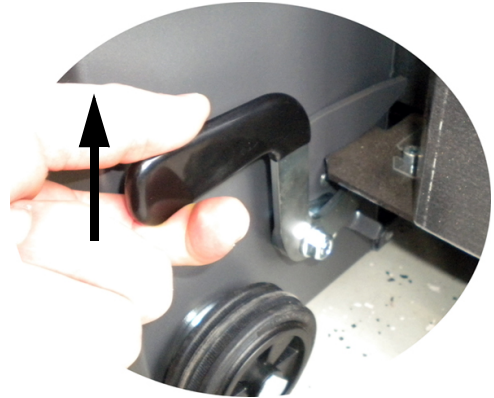

2.

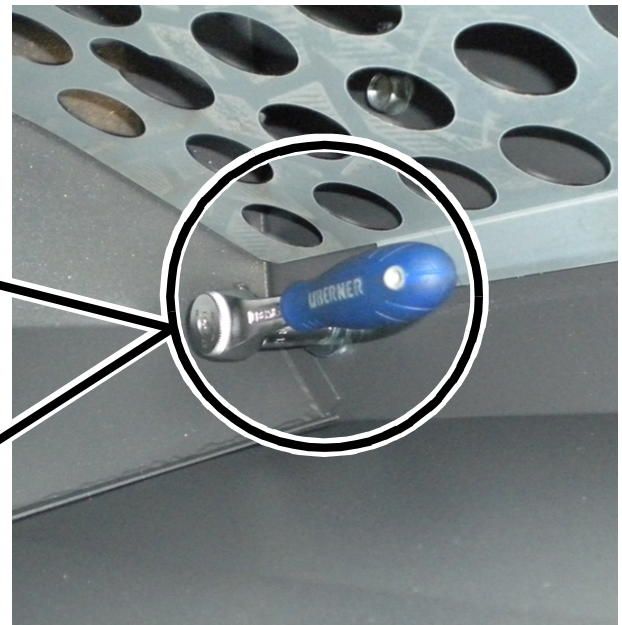
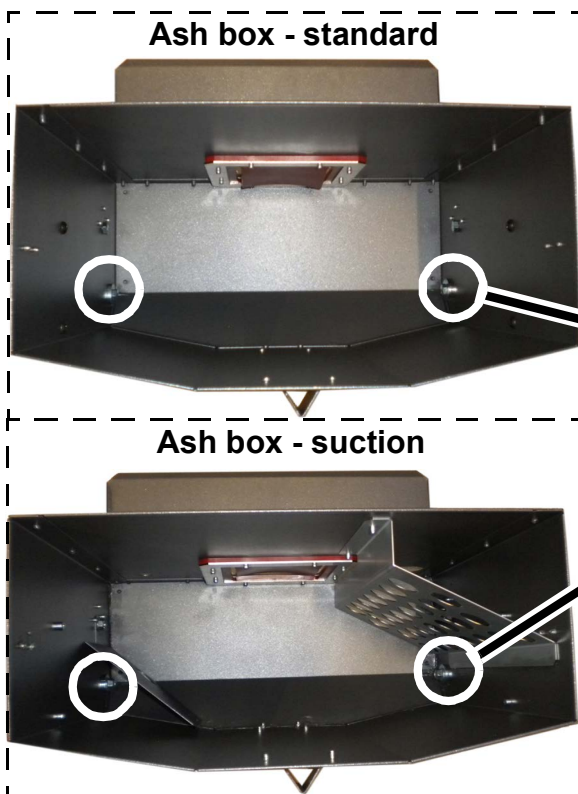

2 x

- ☐ Loosen the M8 nuts

3.

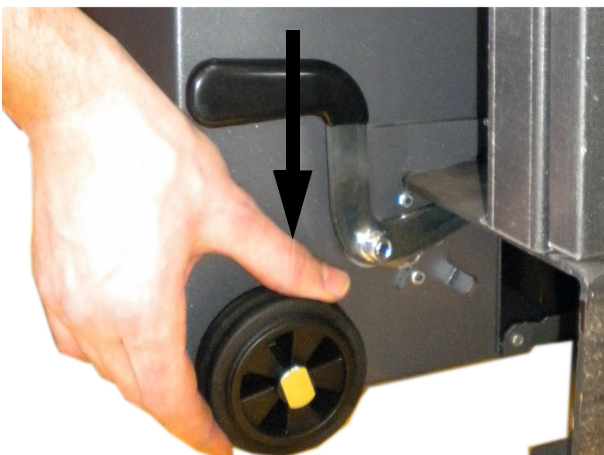

- ☐ Press the wheel against the floor and tighten the nuts again

- ☐ Repeat this process on the other side

12.3 Installing the ash box (60 litres)

12.3.1 Transport handle position

- ☐ In order to change the position of the transport handle, pull the unlocking rod upwards



12.3.2 Adjusting the ash box wheels



- Position the ash box on the boiler and lock in place
 - ☞ Both sides must snap into place



- Remove the ash box lid



- Align the ash box using a spirit level

- Loosen the M8 nut

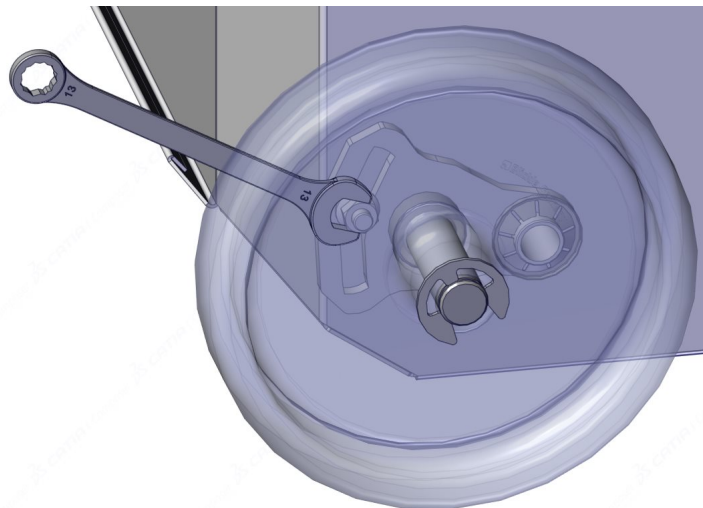

- Press the wheel against the floor and tighten the nut

Repeat this process on the other side

13 Design of the fuel storage room

D A N G E R	
	<p>Dust explosion in the storage room</p> <p>Burns due to explosive burning of dust (pellet dust)</p> <ul style="list-style-type: none">• Ensure proper earthing of transport hoses• No motors in the storage room• No other ignition sources (light) in the storage room• No electrical equipment (switches) in the storage room• No welding work in dusty environments <p>Risk of suffocation from odourless carbon monoxide</p> <ul style="list-style-type: none">• Ventilate sufficiently before entering the storage room• Keep window/door open while inside• Position second person outside to supervise

Design your fuel storage room in accordance with local regulations (e.g. EN ISO 20023 or VDI 3464).

- A separate fuel storage room is required for fuel quantities $> 15 \text{ m}^3$; see the regulations specific to your country, e.g. TRVB 118 H
- No electrical devices in the storage room; all lines to be installed concealed
- Only install filling sockets and anti-rotation protection that are made from metal and grounded using a bonding conductor
- Consider noise protection for wall openings
- Protection against moisture, water and dust
- Correctly position impact protection mat and install slant floor
- Ventilation of the storage room according to legal requirements

13.1 Pellet storage room ventilation

- ☞ Storage rooms and storage containers must be ventilated to prevent a dangerous CO concentration

General ventilation functions:

- Ensure the exchange of air between the storage room and ambient air
- Install ventilation lines as short as possible and with as few changes of direction as necessary
 - ☞ Lowest possible pressure loss
- Preferably lead ventilation into the open air
 - ☞ Prevent rainwater entering through ventilation openings
- Design ventilation cross-sections according to local legal requirements
 - ☞ Various cross-sections depending on the size and design of the storage room

13.2 Safety in the fuel storage room

Observe the instructions on the fuel storage room sticker.

FUEL STORAGE ROOM SAFETY PELLETS	
HARGASSNER  <small>HEIZTECHNIK DER ZUKUNFT</small>	
D A N G E R	
    	<p>Unauthorized access to the fuel storage room is prohibited. Keep children away! Prior entering: Switch off the boiler main switch on the boiler control!</p> <p>Large pellet storage rooms produce odourless carbon monoxide in dangerous concentrations. Sufficiently ventilate and measure the gas content in the pellet fuel storage prior entering! Keep doors open during the stay! Have a second person outside the storage room to supervise!</p> <p>Avoid access to the fuel transport auger and other moving parts!</p> <p>Do not use an open fire or smoke in the area of the fuel storage room!</p>
W a r n i n g	
 	<p>Switch off the boiler before blowing pellets into the storage room! Flue gas may be vacuumed from the boiler - Fire hazard</p> <p>Protect fuel against moisture!</p>

- Explain the contents of the sticker to the operator in detail
- Apply the sticker in the access area to the fuel storage room (storage room door, etc.) so that it is clearly visible and is read again before filling the storage room
- Apply the sticker to a flat, well-adhering surface

14 Facilities on site

14.1 Country-specific regulations

	A T T E N T I O N
	<p>Observe country-specific regulations</p> <p>The regulations and safety regulations for operating combustion systems and the storage of fuels vary from country to country</p> <p>Check country-specific regulations prior to commissioning the combustion system</p> <ul style="list-style-type: none">☞ Fire protection☞ Operating combustion systems☞ Storage of fuels☞ Designs of the boiler room and fuel storage room☞ Requirements from chimney sweep

14.2 Qualification of installation staff

	W A R N I N G
	<p>Risk of death, injuries, damage due to improper installation</p> <ul style="list-style-type: none">• Work on the electrics, hydraulics, components of the flue gas system, structural measures and fire protection must only be carried out by authorised staff• The boiler operator is obliged to have the flue gas system and fire protection checked by licensed authorised bodies

In addition to the operation manual and the binding accident prevention regulations applicable in the country of use and at the place of use, the recognised technical rules for safe and professional work must also be observed.

14.3 Fire extinguisher



Install an inspected (every 2 years) fire extinguisher in an easily accessible place outside of the boiler room right next to the boiler room door.

Boiler room size	Amount of extinguishing powder	Certification
< 20 m ²	6 kg	EN3
20 - 50 m ²	12 kg	EN3

14.4 Designs of the boiler room

- ☞ A boiler room is required for combustion systems with a nominal heating output of over 50 kW
- ☞ Design boiler rooms in accordance with local regulations
- ☞ Ensure fireproof, level and solid floor and ceiling construction
- ☞ Weatherproof and frost-proof (ambient temperatures of up to +40°C)
- ☞ Free of disturbing electrical installations and pipes
- ☞ Do not store any flammable materials near the system

14.4.1 Austrian regulations

- Country-specific boiler room regulation
- Ö-Norm M7510 (inspection of heating systems of solid fuels)
- TRVB 118 H (preventive fire protection)
- TRVB 124 F (first and extended extinguishing help)
- TRVB 105 H (fireplaces for solid fuels)
- TRVB C 141 (outdoor storage of solid, flammable fuels)
- Ö-Norm H5170 (heating systems - requirements for building and safety technology as well as fire and environmental protection)
 - Walls and ceilings REI 90 (F90)
 - Doors EI₂30-C (F30)
 - ☞ Width: ≥ 0.8 m; height: ≥ 2 m
 - Protect storage room against water ingress

14.4.2 German regulations

- FeuVO (fire regulation of federal states)

14.4.3 Swiss regulations

- A boiler room is required for combustion systems with a nominal heating output of over 70 kW
- VKF (Association for Cantonal Fire Insurance Companies) fire safety guidelines
- ☞ Important points from the VKF "Fire protection guidelines" - version 01.01.2017
 - Doors with EI 30 fire resistance and walls with EI 60 fire resistance
 - Walls behind combustion systems must be made of fire-resistant material and be at least 0.12 m thick

14.4.4 Fire resistance of the wall breakthrough

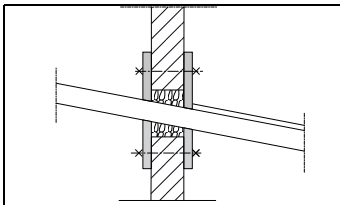

- Ensure that the wall breakthrough complies with the EI 90 fire resistance class
- ☞ Applies if a fuel storage room is required
- Wall opening maximum 50 cm x 50 cm
- Cover with steel sheets (thickness of at least 1.5 mm)
- Cover with fire-resistant plates (thickness of at least 8 mm)
 - ☞ Use at least 10 screws for fixing the cover in place
- Ensure that there is a gap between the wall and the fuel extraction system
 - ☞ Prevents sound transmission
- Filling: fill with rock wool EI 90 (F90)

14.5 Ventilation of the boiler room

For the combustion process, air supply and exhaust openings must be provided in the boiler room.

NOTE	
	<p>Please refer to the local regulations for the size of the air supply and exhaust openings</p> <p>Minimum dimensions: Provide at least one 5 cm² air ventilation opening for each kW system nominal heating output, but these must equate to a total cross section of at least 200 cm². It must be ensured that no impairment is caused by air currents or atmospheric influences. If there are cover grilles or similar installed, the cross-section area must be maintained.</p>

14.6 Flue connection, flue pipe

Description	Unit	Eco-PK 70	Eco-PK 90	Eco-PK 100	Eco-PK 110	Eco-PK 120
Nominal heating output	kW	70	90	99	108	120
Flue gas temperature	°C	140	150	140	150	160
CO ₂	%	14				
Flue gas mass flow rate	kg/sec	0.0389	0.0503	0.0555	0.0607	0.0677
Req. delivery pressure	Pa	5				
Flue draft max. limit	Pa	10				
Flue pipe diameter	mm	180				

The flue gas system must be designed in accordance with local regulations or ÖNORM EN 13384-1.

- The flue pipe is rising towards the flue and should be as short as possible
- Install appropriate openings for cleaning
- Insulate the flue pipe
 - ☞ Protection from hot surface on the flue pipe (risk of burns)
 - ☞ Protection from flammable parts and materials (e.g. electrical wiring)
 - ☞ For reducing condensation
 - ☞ Insulation (foil-laminated rock wool) 30 mm, optimum > 50 mm
 - ☞ Tape joints
- No flammable materials within 20 cm of an insulated flue pipe

14.7 Flue draught stabiliser

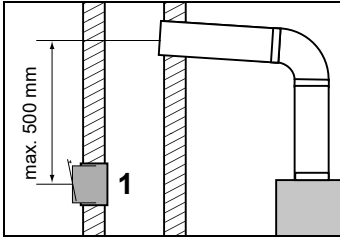

A flue draught stabiliser with an explosion protection flap (1) must be installed in the flue beneath the junction of the flue connection.

- Set the flue draught stabiliser to 10 Pa using the gas meter
- Install the flue pipe rising towards the flue
- ☞ Maximum distance to the flue pipe junction in the flue 500 mm
- ☞ A flue draught stabiliser installed in the flue is beneficial in overpressure situations and when the flue draught is poor

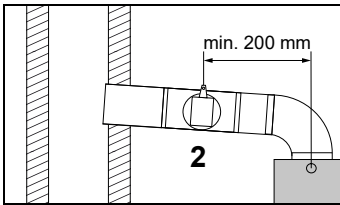

If installation in the flue is not possible, a flue draught stabiliser with an explosion protection flap (2) must be installed in the pipe connecting to the flue.

- ☞ Minimum distance to the flue gas sensor 200 mm

For flue draughts below 30 Pa, the flue draught stabiliser can be shut off.

15 Hydraulic installations

- Install the hydraulics according to the enclosed hydraulic schematic
 - ☞ Design criteria according to EN 12828
 - ☞ Piping and seals must be able to withstand a maximum temperature of 110°C
 - ☞ Note the connection descriptions on the system
- Use an accumulator tank with sufficient volume
 - ☞ A domestic hot water mixer is mandatory for an accumulator tank with integrated domestic hot water coil
- Connect all safety devices
 - ☞ MOE, AFE, thermal safety circuit
- Check the opening direction of the mixer
- Install the control valves according to the hydraulic schematic
- Install the sensors according to the hydraulic schematic
 - ☞ See "Sensor installation" on page 39.
- The chemical and physical properties of heating water must comply with country-specific standards (EN 12828, ÖNORM H 5195-1, VDI 2035, SWKI BT 102-01, SIA 384)
- The electrical conductivity of the heating water should be between 20 and 200 µS
- When filling with heating water, no air must enter the heating system - vent the filling hose before connecting it
- Only use approved heating filling devices for filling with heating water

15.1 Back-end protection unit

	A T T E N T I O N
	<p>Corrosion due to condensation in the boiler</p> <p>Damage to the system due to aggressive condensate</p> <ul style="list-style-type: none"> • Install back-end protection properly and according to the hydraulic schematic

If the system drops below the dew point, condensation water will form. This combines with combustion residues to form an aggressive condensate and leads to corrosion in the boiler.

- ☞ As long as the temperature of the heating water return to the system is below the minimum return temperature for the system, the system's flow heating water is added.
 - ☞ Regulation to constant return temperature
 - ☞ An admixture is almost always used

15.1.1 Hargassner back-end protection

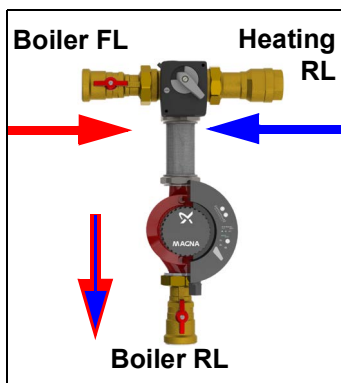

- ☞ Install the back-end protection on the side of the boiler
 - ⇒ See enclosed installation manual
- ☞ Be aware of the mixer direction

The mixer is **closed** when the system circuit is closed or the mixer is **open** when the system circuit (**RL**) is open.

During operation, the return temperature increases when the mixer **closes** and it decreases when the mixer **opens**.

- Install a venting device
- Vent the pump

15.1.2 Position of the cock plug

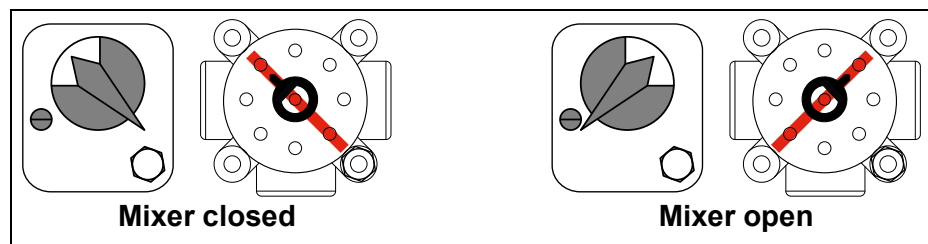

 Position of the cock plug



- ☞ The mixer is **closed** when the system circuit is closed
 - ☞ Maximum back-end protection, no energy for heating
- ☞ The mixer is **open** when the system circuit is open
 - ☞ Minimum back-end protection, maximum energy for heating. During the heat-up phase, the mixer moves to the **closed** position to reach the return temperature as quickly as possible. Once the return temperature has been reached, the system control will open the mixer valve to maintain a constant return temperature

15.1.3 Back-end protection on site

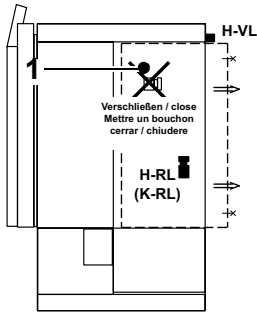
RAG - bauseits / on site /
Sans Groupe de Recyclage /
no incluido / in loco



- Remove the side boiler cover
- Seal unused connection (1)
 - ☞ Be aware of the mixer direction
- Install a venting device
- Vent the pump

15.2 Domestic hot water mixer

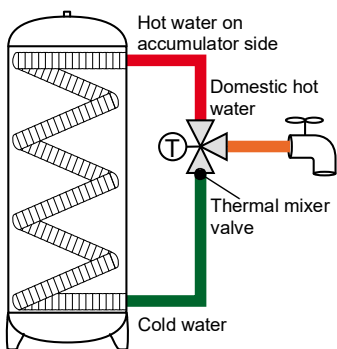

Hot water heating using an accumulator tank with an integrated domestic-hot-water coil, an integrated HWT or an external HWT.

- ☞ To protect against scalding, a thermal mixer valve must be installed

15.3 Safety group

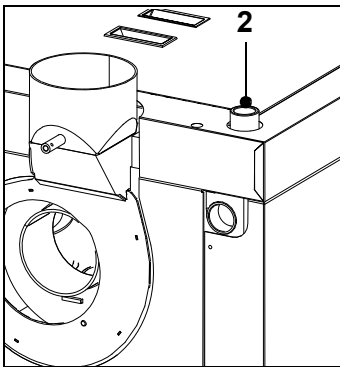

- Connect safety group at the top of the boiler (2)
- Check for leaks



NOTE



Connecting the drain to the safety valve

To ensure safe drainage after the safety valve has been triggered, a hose or pipe must be connected that leads into the drain. The drain with drain funnel must be free to inspect in order to detect any leaks (dripping) of the valve.

16 Electrical installations



DANGER

Danger to life

Electric shock from contact with live terminals

- Observe information signs
- Before starting work, check that no voltage is present using a voltmeter

A detailed electrical manual is enclosed to help with the electrical installation.

- Wiring diagram
- Electrical diagram of the sensors, motors, pumps, mixers, proximity switches
- Information regarding connecting the main power switch in front of the boiler room door
- Instructions on extending the cables

Working on the system's electrical equipment

- The electrical connection has to be executed according to the enclosed electrical manual through a licensed and authorised electrician
- Connect equipotential bonding conductor
- Suction hoses (if used) must be earthed (see sticker)



WARNING

Fire hazard

Risk of injuries and damage from flammable material

- Pay attention to the flue pipe (connecting element)
- The insulation of cables and cable shafts is flammable
- Distance of electrical wires to the connection pipe

When laying the electrical cables outside the system (main connection, sensors, pumps, mixer control), make sure you observe the minimum distance to the hot flue pipe and exhaust fan.

- Power supply to the control unit
- Protection of the power supply with back-up fuse according to electrical diagram
 - ☞ Note the instructions in the wiring diagram
- Main heating switch (emergency stop) in front of the boiler room door
 - ☞ Install a horn or warning light so that it can be noticed easily and reliably
 - ☞ Complete disconnection of the electrical power supply to the control unit
- Connection of all necessary safety equipment
 - ☞ All sensors for safe operation of the boiler (according to wiring diagram)
- Connections of heat circuits (pumps, mixers, sensors)
- Install outside temperature sensor
 - ☞ Do not install in direct sunlight
- Connect the earthing terminal on the system to the protective earth conductor in the control cabinet

16.1 Installing the main power switch

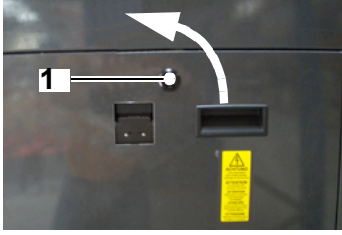

- Open the turn-type lock **(1)** using the plastic key (on the combustion chamber door handle)
- Open and remove the cover from the control box

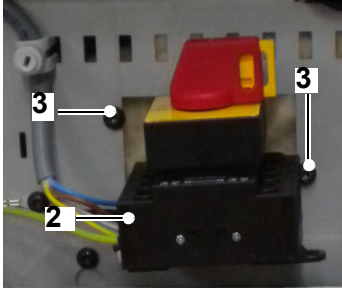

- Loosen two self-tapping screws **(3)** on the board base plate

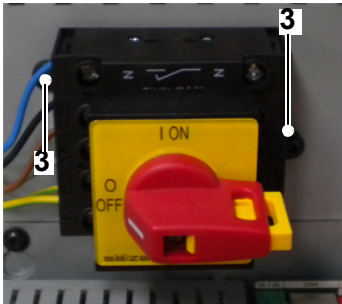

- Remove the main power switch **(2)** and position it correctly
 - ☞ Position **On** must be at top
- Fix the main power switch at the two fastening points on the board base plate
 - ☞ 2 self-tapping screws **(3)**
- Refit the cover on the control box
- Lock again using the turn-type lock

- Turn the main power switch **(2)** to position **0**
- During installation, keep the machine locked to prevent any unexpected movements
 - ☞ Keep the key in a safe place

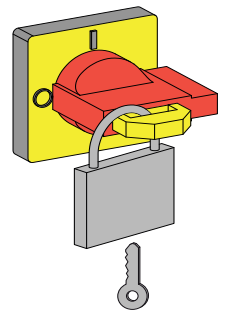

16.2 Cable installation

- Connect the cables and sensors according to the enclosed electrical manual

17 Sensor installation

17.1 Outdoor sensor



Position

- Coldest side of building away from the sun (North; North-East)
- Installation height min. 2 m
- On insulated external walls
- Check for external heat sources (falsification of measured values)
 - ☞ Flue, warm air from air ducts, windows and doors
- Cable outlet from sensor on bottom
 - ☞ Prevent moisture ingress
- Electrical installation with 2-pole cable
 - ☞ See the wiring diagram for the minimum cross section

17.2 Flow, accumulator and external heat sensors



According to the hydraulic schematic
Temperature sensors (except the flue gas sensor) designed as a PT 1000 immersion sensor with a pre-connected sensor cable.

- ☞ Do not damage or bend the sensor cable
- ☞ When extending the cable, bear the minimum cross section in mind

17.2.1 Flow sensor for heat circuits

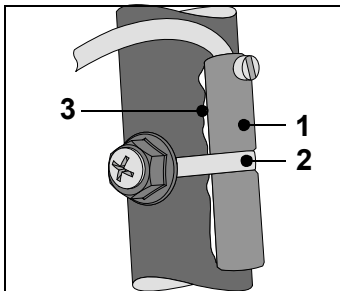

Position

- Approx. 50 cm after the circulating pump
- Metallic bare pipe surface
- Secure with enclosed installation material
 - Brass housing (1) and tightening strap (2) or
 - clamp (4)
- Before installing the sensor, apply the heat conducting paste (3) to the point of contact to ensure better heat transfer



17.2.2 Flue gas sensor

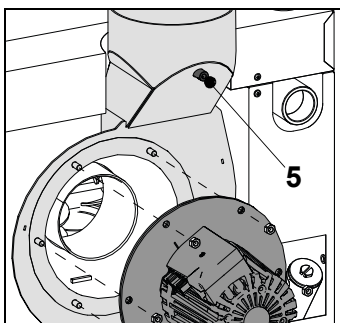

Designed as a thermocouple (type K) with a pre-connected sensor cable.

- ☞ Do not damage or bend the sensor cable
- ☞ When extending the cable, bear the minimum cross section in mind
- Insert the sensor tip into the opening (5) on the exhaust fan and secure with the spring

17.2.3 Boiler, HWT, accumulator and external heat sensors

- ❑ Install the sensor using the immersion sleeve
- ❑ Position the accumulator- and HWT sensor

	NOTE
	<p>Correct sensor positions</p> <ul style="list-style-type: none"> Correctly position the sensors in order to control the HWT and accumulator loading processes

External HWT

Sensor resistance values

Boiler, HWT, accumulator, flow, return, outside and external heat sensors	
in °C	in Ohm
-20	922
-10	960
0	1000
10	1039
15	1058
20	1077
25	1097
30	1116
35	1136
40	1155
45	1174
50	1193
55	1213
60	1232
65	1252
70	1270
75	1290
80	1309
85	1328
90	1347
95	1366
100	1385
Room temperature sensor (FR25 remote control) Automatic switch position (clock) and central position of the remote adjuster (regardless of room temperature)	
3340 - 3650 Ω	

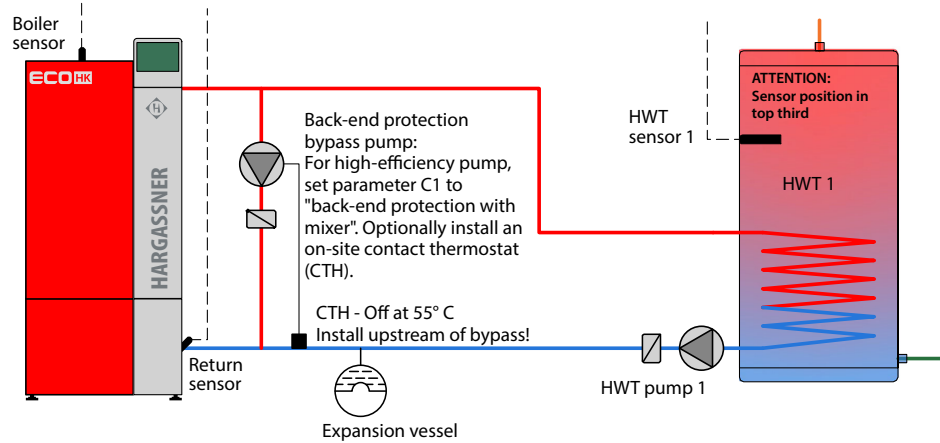

Accumulator and external HWT

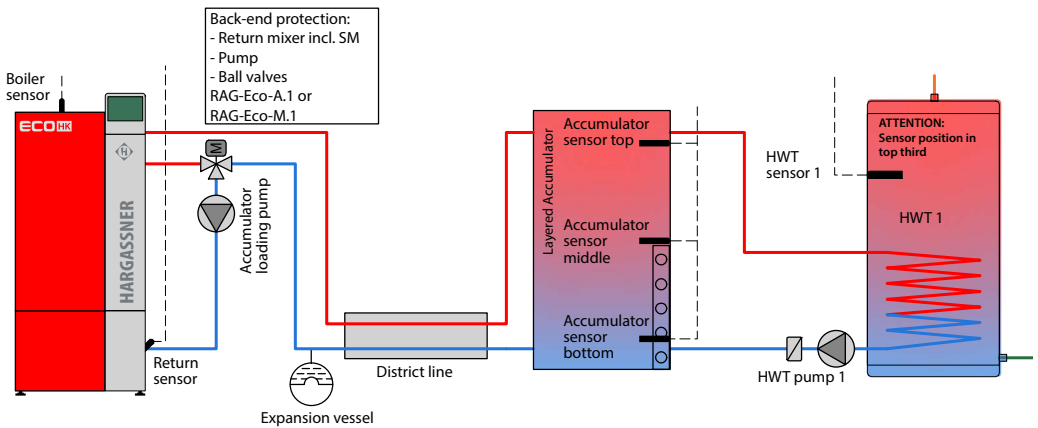

18 Remote control FR25 / FR35 / FR40

☞ For professional installation and operation of the remote control, see the installation and operating instructions of the respective remote control

Caution: In the installer settings, the corresponding remote control must be parameterised to the assigned heat circuit.

Install the remote control at an easily accessible position

Place of installation

- No direct sunlight, draught, radiators, flue, etc.
 - ☞ Measurement of the actual room temperature
- In the most appropriate room (e.g. living room or dining room)
 - ☞ No stove (e.g. a tiled stove) may be heated in this room
 - ☞ Set the radiator thermostat to a temperature higher than the room temperature on the control unit
 - ☞ Influences the room sensor
 - ☞ Heat circuit flow is adjusted, causing other rooms to become too cold or too warm

18.1 FR25 remote control (analogue)



Can be used for heat circuits connected to the HKM or HKR (not for heat circuits of heat circuit board A).

Remote control with room sensor

Connect terminal 1 and 2 (for FR25)

Remote control without room sensor

Connect terminal 1 and 3 (for FR25)

Fault lamp

The FR25 remote control has a red LED, which can be connected to the boiler. This LED lights up on the control unit when a warning or an error is displayed.

Connect terminal 4 (+) and 5 (-) (for FR25)

18.2 FR35 remote control (digital)



Can be used for all heat circuits (HKM, HKR and HC A).

Bus cable 2x2x0.5 mm², shielded and pair-twisted (e.g.: LiYCY)

☞ For cable lengths from 100 m, a cross-section of 0.75 mm²

18.3 FR40 remote control (digital)



Can be used for all heat circuits (HKM, HKR and HC A).

Bus cable 2x2x0.5 mm², shielded and pair-twisted (e.g.: LiYCY)

☞ For cable lengths from 100 m, a cross-section of 0.75 mm²

19 Extension module, board or controller

19.1 Extension module 0, 1, 2



Up to three extension modules may be connected to extend heat and HWT circuits. The connection to the boiler board is formed by a bus cable (on the CAN plug).

- Set the address selection switch on the extension module (default: **0**)
 - **0** for HKM 0 = heat circuit 1+2 and HWT circuit 1
 - **1** for HKM 1 = heat circuit 3+4 and HWT circuit 2
 - **2** for HKM 2 = heat circuit 5+6 and HWT circuit 3

19.2 Additional board I/O 36 (HC AB/F, 5-sensor accumulator or differential controller)

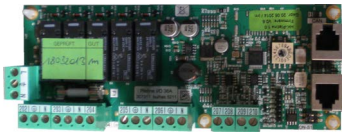

The heat circuit board is for the extension of HWT and heat circuits on the boiler. The connection to the boiler board is formed by a bus cable.

- Default address switch of the heat circuit board
 - **A** for HC A = heat circuit A and HWT circuit A
 - **B** for HC B = heat circuit B and HWT circuit B
 - **C** for AS board = 5-sensor accumulator
 - **D** for D control board = differential controller
 - **F** for HKF = controlled district line

19.3 Heat circuit controller HKR



Up to 16 heat circuit controllers can be connected to extend the heat and HWT circuits, as well as accumulator tanks and external heat boilers. The connection to the boiler board is formed by a bus cable (on the CAN plug).

- Set the address selection switch on the heat circuit controller (default: **1**)
 - **0** for HKR 0
 - **1** for HKR 1, etc.

20 Permits and reporting requirements

Caution: Have the installation or conversion of a heating system approved by the relevant regulatory authority.

- Report any installation or conversion to the supervising office
 - ☞ Austria: Responsible building authority
 - ☞ Germany: Chimney sweep or building authority
 - ☞ Other countries: Observe the regulations of the local authorities

21 Commissioning the boiler

	D A N G E R
	<p>Risk of injury and/or material damage</p> <p>Injuries or damage to the system due to unauthorised commissioning</p> <ul style="list-style-type: none">• The boiler may only be commissioned by staff authorised by Hargassner• Prevent unauthorised commissioning• Do not perform any work on the boiler• Only operate the boiler independently after a commissioning report has been signed

notes

Your expert for **PELLET | WOOD LOG | WOOD CHIP** HEATING

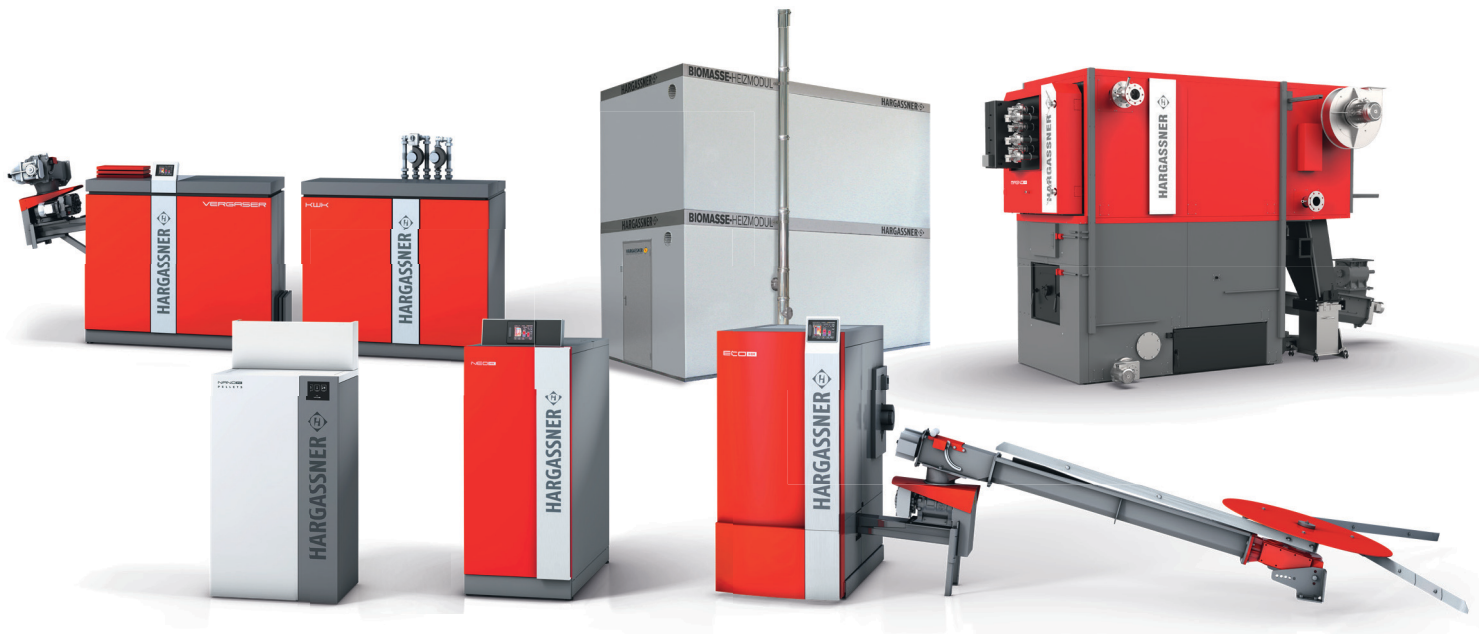
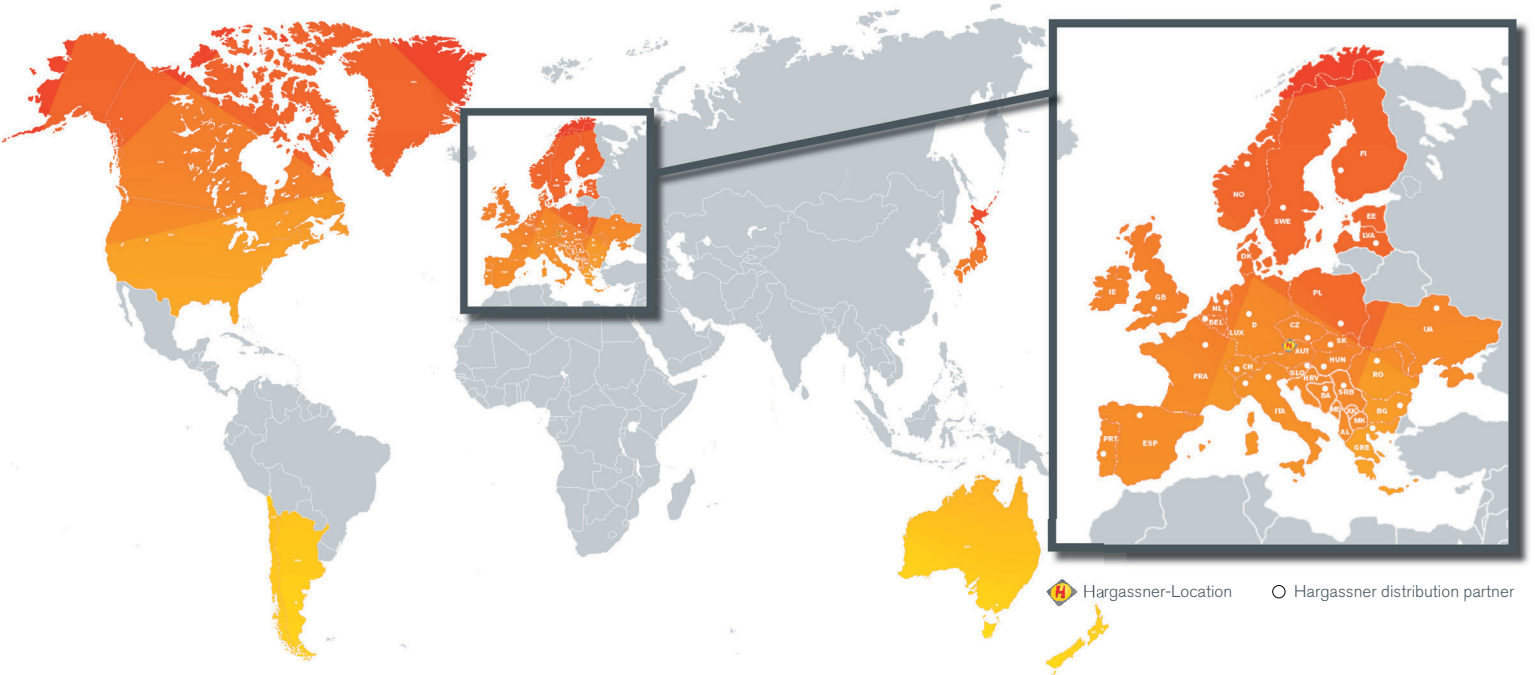

<p>hargassner.com</p>	<p>AUSTRIA HARGASSNER Ges mbH Anton Hargassner Strasse 1 A-4952 Weng Tel. +43 (0) 77 23 / 52 74 Fax +43 (0) 77 23 / 52 74 - 5 office@hargassner.at</p>	<p>GERMANY HARGASSNER DE GmbH Heraklithstraße 10a D-84359 Simbach/Inn Tel. +43 (0) 77 23 / 52 74 Fax +43 (0) 77 23 / 52 74 - 5</p>
---	--	---