



# OPERATION MANUAL

## PELLET BOILER



Eco-PK 250-330

# Contents

<b>Chapter I: Technical Data</b>	<b>5</b>	<b>7.6 Back-end protection</b>	<b>18</b>
<b>1 Dimensions</b>	<b>5</b>	<b>7.7 Differential control</b>	<b>18</b>
<b>2 Intended use</b>	<b>5</b>	<b>7.8 Boiler</b>	<b>18</b>
<b>3 Fuel quality</b>	<b>5</b>	<b>7.9 Accumulator</b>	<b>19</b>
3.1 Pellets A1	5	<b>7.10 External heat</b>	<b>19</b>
3.2 Inadmissible fuels	5	<b>7.11 Consumption</b>	<b>19</b>
3.3 24h of continuous output	5	<b>7.12 Sensor</b>	<b>19</b>
<b>4 Boiler room design</b>	<b>6</b>	<b>7.13 Trend</b>	<b>19</b>
<b>5 Design of the fuel storage room</b>	<b>6</b>	<b>7.14 Electricity</b>	<b>19</b>
<b>6 Design of heat circuits</b>	<b>6</b>	<b>7.15 Counter</b>	<b>19</b>
<b>7 Back-end protection unit</b>	<b>6</b>	<b>7.16 Network</b>	<b>19</b>
<b>8 Flue pipe, chimney connection</b>	<b>7</b>	<b>7.17 Web</b>	<b>20</b>
<b>9 Seasonal space heating emissions</b>	<b>7</b>	<b>7.18 Serial number</b>	<b>20</b>
<b>10 Electrical supply</b>	<b>7</b>	<b>7.19 Error</b>	<b>20</b>
<b>Chapter II: Safety regulations</b>	<b>8</b>	<b>8 Manual operation</b>	<b>21</b>
<b>1 General safety regulations</b>	<b>8</b>	8.1 Functions in manual operation	21
1.1 Obligation to instruct, external visitors and children	8	<b>9 Settings menu</b>	<b>23</b>
1.2 Special measures prior to commissioning by the operator	8	9.1 Customer	23
1.3 Key handover	8	9.2 Installer	23
<b>2 Remaining risks</b>	<b>8</b>	9.3 Service	23
<b>3 Measures in case of danger</b>	<b>9</b>	9.4 Setup	23
3.1 Fire in the boiler room	9	<b>10 Customer settings</b>	<b>25</b>
3.2 After a power outage	9	10.1 HWT control	25
3.3 Leak in heating water system	9	10.2 Control of heat circuits	25
3.4 Leaks in the system (escaping flue gas)	9	10.3 General settings	26
3.5 Auger blockages	9	<b>11 Commissioning settings</b>	<b>29</b>
<b>Chapter III: Operation</b>	<b>10</b>	11.1 Parametrising the heat circuits and HWT	29
<b>1 Overview of system components</b>	<b>10</b>	11.2 Parameter A - heat circuits	29
1.1 Function	10	11.3 Parameter B - HWT	31
1.2 Operating modes	10	11.4 Parameter C - accumulator	33
<b>2 Prior to commissioning</b>	<b>11</b>	11.5 Parameter D - general	36
2.1 Checks prior to commissioning	11	11.6 Parameter E - languages	38
2.2 Commissioning	11	11.7 Parameter F - cascade	38
2.3 Customer instructions	11	11.8 Parameter G - differential control	38
2.4 Starting the boiler for the first time	11	<b>12 Optional remote controls</b>	<b>41</b>
2.5 Recirculation setting	11	12.1 Digital remote control FR40	41
2.6 Inspections before starting up the boiler	11	12.2 Digital remote control FR35	41
2.7 Procedure when filling the fuel storage room	11	12.3 Analogue remote control FR25	42
<b>3 Control unit</b>	<b>12</b>	<b>Chapter IV: Cleaning</b>	<b>43</b>
3.1 Home view	12	<b>1 Maintenance contract</b>	<b>43</b>
3.2 Touchscreen	12	<b>2 Weekly/monthly cleaning</b>	<b>44</b>
3.3 Standard menu view	13	2.1 Weekly intervals	44
<b>4 Operating modes</b>	<b>14</b>	2.2 Monthly intervals	44
<b>5 System status indicators</b>	<b>14</b>	<b>3 Annual cleaning</b>	<b>44</b>
<b>6 Flue gas measurement</b>	<b>16</b>	3.1 Preparation for cleaning	45
<b>7 Info menu</b>	<b>17</b>	3.2 Cleaning the turbulators and the turbulator chamber	45
7.1 Overview	17	3.3 Cleaning the exhaust fan and the flue pipe	46
7.2 District line pump	17	3.4 Cleaning the lambda sensor and the combustion chamber sensor	46
7.3 External heat circuit	17	3.5 Cleaning the combustion chamber and post combustion chamber	46
7.4 Heat circuits	17	3.6 Cleaning the ignitions	46
7.5 Hot water tank	18	3.7 Cleaning the ash chamber	47
		3.8 Cleaning the fly ash area	47
		3.9 Cleaning the recirculation	47
		3.10 Cleaning the pellet vacuum turbine	48
		3.11 Emptying the ash box	48
		<b>4 Disposal information</b>	<b>48</b>
		4.1 Disposal of created ash	48

4.2	Disposal of wear and spare parts	48
4.3	Disposal of system components	48
<b>Chapter V: Troubleshooting</b>		<b>49</b>
1	Information and error display	49
2	Viewing the error list	49
3	Acknowledging and rectifying an error	49
4	BCE failure	49
5	Temporary emergency operation (restart without HW test)	50
<b>Supplement</b>		<b>51</b>
<b>Declaration of Conformity</b>		<b>52</b>



## Dear customer!

You have chosen an innovative quality product from our company. The product from Hargassner Ges mbH is a state-of-the-art product and manufactured to the latest production standards. We are very pleased about your decision and guarantee that you have chosen a reliable quality product.

However, please be aware that even the best product can only work optimally if installed, commissioned and serviced correctly.

The attached documents provide assistance. To ensure cost-effectiveness and a long lifetime, please follow the enclosed manual. This way, you will avoid high repair costs and long downtimes.

These instructions are intended to make it easier to become familiar with the product and to use it as intended.

The instructions contain important information on how to operate the product

- safely
- appropriately
- in an environmentally friendly manner
- economically

Guidelines within this manual will:

- Prevent hazards
- Reduce repair costs and downtimes
- Increase the reliability and lifetime of the product

Keep this manual within easy reach.

# Chapter I: Technical Data

## 1 Dimensions

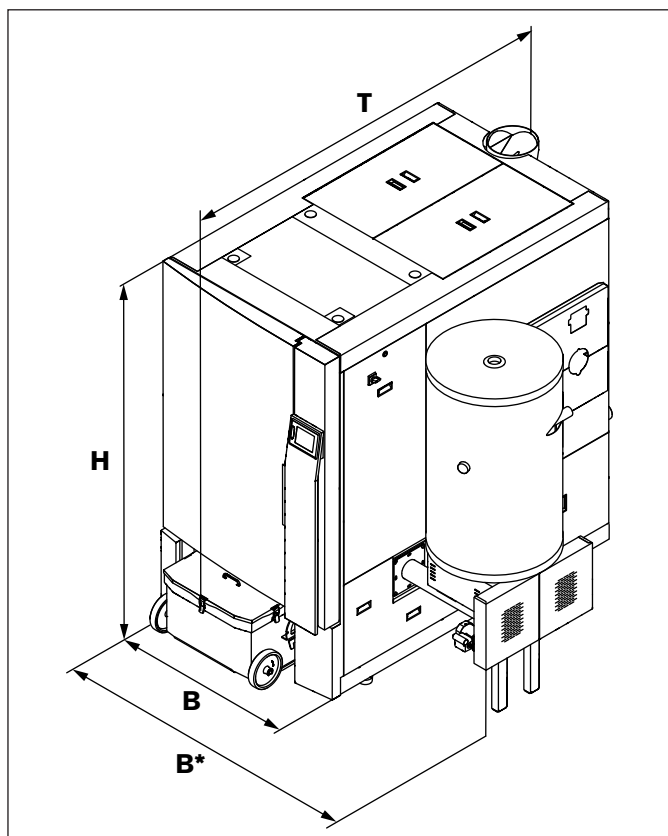

	Name	Value
<b>B</b>	Width	1155 mm
<b>B*</b>	Width including day hopper	1950 mm
<b>T</b>	Depth	2290 mm
<b>H</b>	Height	2015 mm
	Weight	2150 kg

## 2 Intended use

The automatic wood pellet system is designed to heat up water only. Only fuels permitted by Hargassner may be burned in this system. Only use the system in technically perfect working order. Rectify errors immediately.

Intended use also includes observing all items in this manual and adhering to the inspection and maintenance instructions.

## 3 Fuel quality

Only use fuels that comply with **EN ISO 17225-2**.

### **i** NOTE

Only use fuels approved and permitted by Hargassner Ges mbH. Have new fuels and feasibility checked and approved by Hargassner Ges mbH.

The specified nominal output of the boiler is verified by a test with standardised test fuel under optimal conditions. If different fuel and operating conditions are used, the output of the boiler may deviate from the rated output.

- Pellets test fuel EN ISO 17225-2, class A1

### 3.1 Pellets A1

Ensure quality standards, when wood pellets are ordered and delivered.

- Least possible dust content
- Pellets with a hard and shiny surface
- 100% natural wood, no additives, etc.
- Pellets class **A1** defined in **EN ISO 17225-2** and **EN ISO 20023**

### 3.2 Inadmissible fuels

- Fuel with water content >15%
  - Formation of condensate
  - Increased corrosion in the boiler
- Paper, cardboard
- Chip boards, impregnated timber
- Black coal, brown coal or lignite
- Waste
- Plastics

### 3.3 24h of continuous output

The 24h of continuous output is only achieved with the specified fuel quality.

Boiler	24h of continuous output
Eco-PK 250	5378 kWh
Eco-PK 300	6458 kWh
Eco-PK 330	7128 kWh

## 4 Boiler room design

Boiler rooms must be designed in accordance with local regulations.

⇒ See assembly manual

- Keep the system air inlets clear
- Never store flammable materials in the boiler room
- Design the boiler room to be frost-proof
- Maximum ambient temperature up to 40°C
- Ensure fireproof, level and solid floor and ceiling construction
- In accordance with regulations, have the main heating switch installed by an electrician (depending on building regulations)
- Fire extinguisher

## 5 Design of the fuel storage room

Design your pellet fuel storage room in accordance with local regulations (e.g. EN ISO 20023 or VDI 3464).

⇒ See assembly manual

- Only install metal fill pipes, earthed and connected to outside
- Consider noise protection for wall openings
- Protection against moisture, water and dust
- Correctly position impact protection mat and install slant floor

### DANGER

#### Risk of explosion

##### Burns due to explosive burning of dust (pellet dust) in the storage room

- Ensure that the pellet hoses are earthed.
- No motors in the storage room.
- No other ignition sources (light) in the storage room.
- No electrical equipment (switches) in the storage room.
- No welding works in a dusty environment.

### DANGER

#### Risk of suffocation

##### Risk of suffocation from odourless carbon monoxide

- Ventilate sufficiently before entering the storage room.
- Keep window and door open while inside.
- Position second person outside to supervise.

## 6 Design of heat circuits

Proper design of the heat circuits is essential for optimum system operation.

⇒ See enclosed hydraulic schemes

Accumulators, pumps and mixers for heat circuits must be designed according to current standards by the commissioning engineer

## 7 Back-end protection unit

If the temperature of the heating-water return is below the value preset in the parameters, hot flow from the system is mixed to the return. Use of a back-end protection unit is mandatory when operating the system.

⇒ See assembly manual

## 8 Flue pipe, chimney connection

Description	Unit	Eco-PK 250	Eco-PK 300	Eco-PK 330
Nominal heating output	kW	249	299	330
Flue gas temperature	°C	140	150	150
CO <sub>2</sub>	%		14	
Flue gas mass flow rate	kg/sec	0.1385	0.1666	0.1841
Req. delivery pressure	Pa		2	
Max. flue draught	Pa		10	
Flue pipe diameter	mm		250	

### **i** NOTE

A flue draught stabiliser with an explosion protection flap (set to 10 Pa) must be installed in the chimney or flue pipe.

### **i** NOTE

After a soot fire, clean your flue pipes and replace all the flue pipe seals.  
Ensure optimum seal tightness for the flue pipes and chimney connections.

## 9 Seasonal space heating emissions

Description	Unit	Eco-PK 250	Eco-PK 300	Eco-PK 330
Carbon monoxide	mg/m <sup>3</sup>	38	43	46
Nitrogen oxide	mg/m <sup>3</sup>	129	118	111
Gaseous organic compounds	mg/m <sup>3</sup>	<2.8	<2.8	<2.6
Dust	mg/m <sup>3</sup>	11	9	9

Seasonal space heating emissions at 10% residual oxygen in dry flue gas

## 10 Electrical supply

⇒ See Electrical manual

Description	Characteristics
Voltage	400 V ± 5%
Frequency	50 Hz ± 5%
Back-up fuse	13 A
Power consumption <sup>1</sup>	286 - 384 W

- The electrical supply may only be established by a licensed and authorised electrician and must be in accordance with the enclosed electrical manual
- Attach a lockable main power switch outside the boiler room (as per building regulations)
- Max. back-up fuse **13 A** (C type)
- It is absolutely imperative that the intrinsically safe cables are permanently installed
  - Use suitable mechanical fixing material
- Establish mains supply L and N (see electrical manual)
- Connect equipotential bonding conductor
- Use highly flexible cables (e.g. H05VV-F)

<sup>1</sup> Calculated in accordance with the EN 303-5 testing requirements without the pumps and fuel extraction system.

## Chapter II: Safety regulations

### 1 General safety regulations

#### 1.1 Obligation to instruct, external visitors and children

##### DANGER

###### Danger to life

###### Risk of death, injuries, damage due to improper use by unauthorised persons

- Observe the safety instructions of the system and in the operation manual.
- Read the user manual prior to commissioning.
- Only let qualified and trained staff work on the system.
- Decide who is responsible for managing the system.
- Keep external, unauthorised people away from the system and the storage room.
- Do not disclose access codes for the control unit.
- Observe the legal minimum age of staff.
- Place prohibition sign on boiler room door and fuel storage door.

##### DANGER

###### Risk of suffocation

###### Risk of suffocation from odourless carbon monoxide

- Ventilate sufficiently before entering the storage room.
- Keep the windows and doors open while inside.
- Position second person outside to supervise.

Work on the boiler's electrical parts must only be carried out by an electrician and in accordance with the electrical engineering regulations.

Work on hydraulic systems must be carried out only by personnel with specialised knowledge and experience in heating engineering and pipework construction.

#### 1.2 Special measures prior to commissioning by the operator

- Observe your local official regulations for system operation and accident prevention
- Carry out the required checks prior to commissioning  
⇒ „Checks prior to commissioning“, p. 11
- Carry out the required checks before switching the system/boiler on  
⇒ „Inspections before starting up the boiler“, p. 11

### 1.3 Key handover

##### DANGER

###### Risk of injury and/or material damage

###### Injuries or damage to the system due to unauthorised commissioning

- Prevent unauthorised commissioning.
- Secure (lock) the system against commissioning and keep the keys safe.

## 2 Remaining risks

The following residual risks must be particularly taken into account when the system is operated properly and in accordance with its intended purpose:

##### DANGER

###### Risk of burns, risk of scalding

###### Burns due to hot surfaces or hot ash

- Shut down the system and let it cool down before carrying out any maintenance or servicing work.
- Do not reach into the system during operation.
- Wear heat-resistant safety gloves. The ash in the ash container stores heat.
- Do not empty hot ash into dustbin.
- Put hot ash in closed, not-flammable vessels only.

###### Scalds due to sprinkling, hot water

- Check all lines, hoses and connections regularly for leaks and any other damage visible from the outside.
- Rectify damage immediately.
- Before performing any maintenance work on the water circulation system, depressurise the system.
- Check that all valves are in the correct position.

##### DANGER

###### Risk of fire, explosion and deflagration

###### Dust explosion due to electro-static charging in the storage room

- Ensure that the pellet hoses are earthed.
- No motors in the storage room (acc. to country-specific regulations).
- No other ignition sources (light) in the storage room.
- No electrical equipment (switches) in the storage room.
- No welding works in a dusty environment.

**⚠ DANGER****Risk of deflagration, explosion and fire****Burns from explosive combustion of residual gases (CO)**

- Carefully open the combustion chamber door slightly first.
- Hold back body and face from the combustion chamber door.
- Do not open the combustion chamber door during or immediately after a power failure, as this increases the risk of deflagration.
- Do not open combustion chamber door during heating operation.

**⚠ DANGER****Risk of injury****Risk of crushing and amputation due to moving parts**

- Refrain from accessing augers or motors when the boiler is switched on.
- Do not work on the system while people are in the danger zone. Secure and lock storage room.
- Only clean the augers and remove blockages using suitable tools and when the system is switched off.
- Only eliminate cavity formations using rods or shovels.
- Wear safety shoes.
- Observe the storage room sticker.

**⚠ DANGER****Danger to life****Electric shock from contact with live terminals**

- Only operate with safety devices and cover parts mounted and functional.
- Observe information signs.
- Before starting work, check that no voltage is present using a voltmeter.

**⚠ DANGER****Risk of poisoning and suffocation****Death, poisoning or suffocation due to flue gas in the boiler room or in the building**

- Check system doors and seals for leaks.
- Burning treated wood (paints, varnishes, waterproofing) creates toxic ash. Avoid skin and eye contact.

**⚠ WARNING****Risk of injury and/or material damage****Injuries and/or damage due to unexpected operating conditions**

- When working in manual mode, limit switches and motors are not automatically monitored. Only run the augers backwards briefly (max. 2 seconds).
- Allow qualified and trained staff only to manually operate the system.

## 3 Measures in case of danger

### 3.1 Fire in the boiler room

- Switch off boiler emergency switch and disconnect power supply to boiler room
- Contact the fire service immediately
- Fight the fire with a fire extinguisher

### 3.2 After a power outage

Do not open the boiler's doors or reach into it during a power failure.

- Danger of deflagration
- Danger of crushing by the augers

After the electrical supply is switched on again, the control starts in **Heat up** mode and monitors the flue gas temperature.

- If the flue gas temperature rises, the system heats up and regulates the transfer of heat according to the preset parameters

### 3.3 Leak in heating water system

When the water pressure is too low, not enough heat is transferred from the boiler to the heat circuits, the HWT and the accumulator.

- Danger of boiler overheating
- Stop heating up the boiler
- Fix leak
- Fill / refill water circulation system
- Check water pressure

### 3.4 Leaks in the system (escaping flue gas)

- Stop heating up the boiler
- Check the seals of the doors and cleaning covers, and have them replaced

### 3.5 Auger blockages

Do not touch the blocked augers.

- Danger of crushing from sudden release of blockage
- Briefly run the blocked auger backwards in manual mode (max. 2 seconds)
  - Danger of fuel being compressed in the auger
- Only clean the augers and remove blockages using suitable tools and when the main power switch is turned off and locked

## Chapter III: Operation

### 1 Overview of system components

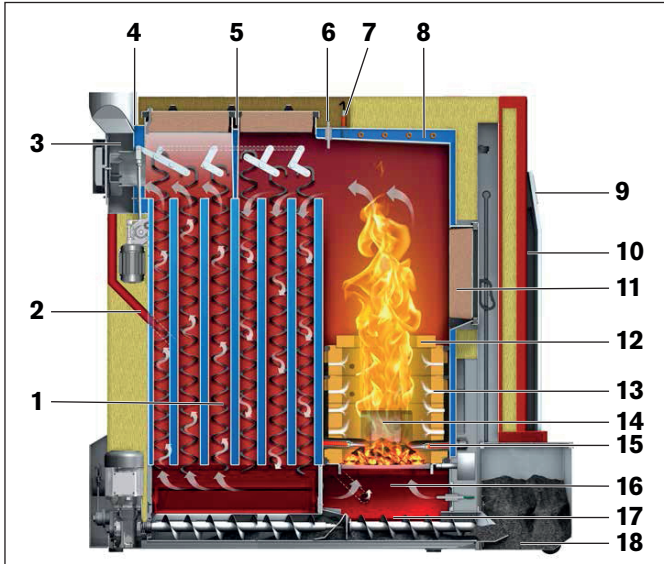

Item	Name
1	Turbulators
2	Recirculation
3	Flue gas sensor
4	Exhaust fan
5	Cleaning cover
6	Combustion chamber sensor
7	Lambda sensor
8	Heating coil of thermal safety circuit
9	Control unit
10	Boiler cover door
11	Combustion chamber door
12	Flame concentration jet
13	Refractory
14	Firebed monitoring
15	Ignitions (2 x 300W)
16	Double rotary step grate
17	Ash auger
18	Ash box

The system consists of the combustion chamber and the heat exchanger and controls the combustion air with the exhaust fan and air flaps.

The lambda sensor consistently monitors the flue gases. The integrated sensors monitor the temperatures of the system and the flue gas. The turbulators clean the heat exchanger using a rod. The system cleans itself at regular intervals using the de-ash system. The ash extraction auger transports the fly ash, as well as the grate ash into the ash box.

Ignition is via two automatic energy-saving ignitions (300 W).

#### 1.1 Function

- Fuel transport from the storage room
- Transport of the fuel into the combustion chamber
- Ignition and combustion of the fuel
- Control of heat transfer to the heating-water system
- Cleaning of the system and the ash extraction into the box
- Evacuation of the flue gases

#### 1.2 Operating modes

- Automatic mode
- HWS operation
- Manual operation
- Off (frost protection and residual heat use activated)
- Firing Off

## 2 Prior to commissioning

### DANGER

#### Danger to life and risk of material damage

##### Death, personal injury and/or damage due to missing, defective or bypassed safety devices or system parts

- Check safety devices and system parts carefully to ensure they are working properly and as intended.
- Never modify or bypass safety devices.
- Perform repair measures immediately in case of a malfunction or defect.
- Place, position and function of all safety devices must be known.

### DANGER

#### Risk of injury

##### Injury and/or damage due to unexpected operating states

- Make sure that commissioning or start-up is performed by Hargassner GmbH or specially trained staff.

### WARNING

#### Risk of injury and crushing

##### Danger of crushing from moving system parts

- Make sure that no persons are in the danger zone.
- Do not reach into any reachable mechanical parts.
- Do not stand on the system.
- Make sure that no foreign parts (tools, etc.) remain in the system.

## 2.1 Checks prior to commissioning

- Safety on-site and plumbing and electrical installations
- Correct assembly of the boiler/system
- Check all necessary components
  - Check tightness, proper function, rotation of all motors, etc.
  - Check correct position of combustion chamber lining

## 2.2 Commissioning

Once the boiler has been installed properly and all the required safety devices have been checked, the boiler can be commissioned in accordance with the commissioning checklist in the inspection book.

### NOTE

The boiler must be commissioned by an engineer with a Hargassner commissioning certificate. The completed commissioning and handover report must be sent back to Hargassner Ges mbH with the commission number within 30 days of commissioning, otherwise the warranty becomes void. A copy remains in the commissioning book on-site.

## 2.3 Customer instructions

- Explain cleaning and maintenance intervals
- Explain inspections prior to each filling process
- Explain how to operate the boiler and resolve issues

## 2.4 Starting the boiler for the first time

The boiler can be started for the first time once commissioned.

- Switch the system to manual mode
  - Use parameter no. 10 to fill the empty combustion chamber in manual mode
  - Prevents an error due to missing fuel
- Switch the system to **Automatic** mode
  - Boiler starts automatically when hot water is needed

## 2.5 Recirculation setting



- The default recirculation setting is 100%
- Check the recirculation setting prior to commissioning

## 2.6 Inspections before starting up the boiler

- Check water pressure in boiler, heat, HWT and accumulator circuits
- Pay attention to the display for notifications (error messages and operating status)
- Rectify any errors
- Check and lock the fuel storage room

## 2.7 Procedure when filling the fuel storage room

### NOTE

Protect fuel against moisture.

### WARNING

#### Fire hazard

##### Danger of flue gas being sucked in from the system

- Always switch off the system before blowing pellets into the storage room.

### 3 Control unit



#### Risk of injury

#### Injury and/or damage to the system due to unexpected operating states

- Only allow trained staff to operate the control unit.
- Access to all functions of the control unit is protected by codes. Codes may not be disclosed to third parties.

### 3.1 Home view

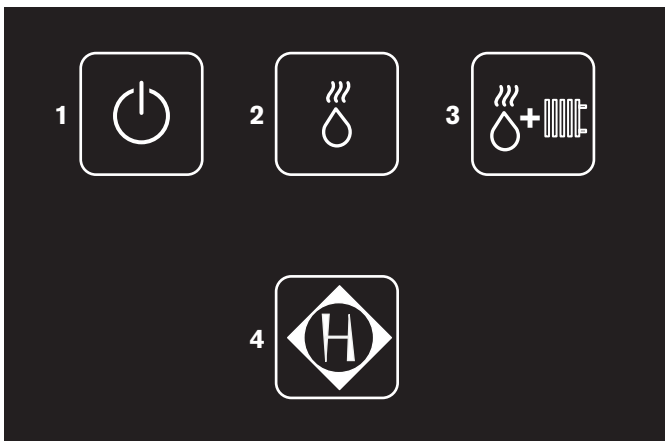

Item	Description	Function
1	Operating mode <b>Off</b>	Quick select button for operating mode <b>Off</b>
2	Operating mode <b>Summer</b>	Quick select button for operating mode <b>Summer</b> (HWT operation)
3	Operating mode <b>Winter</b>	Quick select button for operating mode <b>Winter</b> (Automatic)
4	Standard menu	Switching from <b>Home</b> view to the Standard menu

→ After the time set in the No. 02 Display settings setup parameter has elapsed, the control unit automatically switches to the Home view

### 3.2 Touchscreen

The control unit is designed as a touchscreen.

→ It is operated using finger pressure on the display.

- ☐ Scroll through the menu with
- ☐ Back to previous menu with
- ☐ To return to the Standard menu, press 2x  
→ Possible from every menu
- ☐ Activate the operating mode by pressing the **Function** selection button
- ☐ Activate the input field by pressing it  
→ Values are displayed in Red
- ☐ Change the active values with   
→ Values flash red  
→ Buttons flash green
- ☐ To enter or save any changes, press
- ☐ You can go straight to the customer parameters by pressing the relevant graphic in the standard menu

### 3.3 Standard menu view

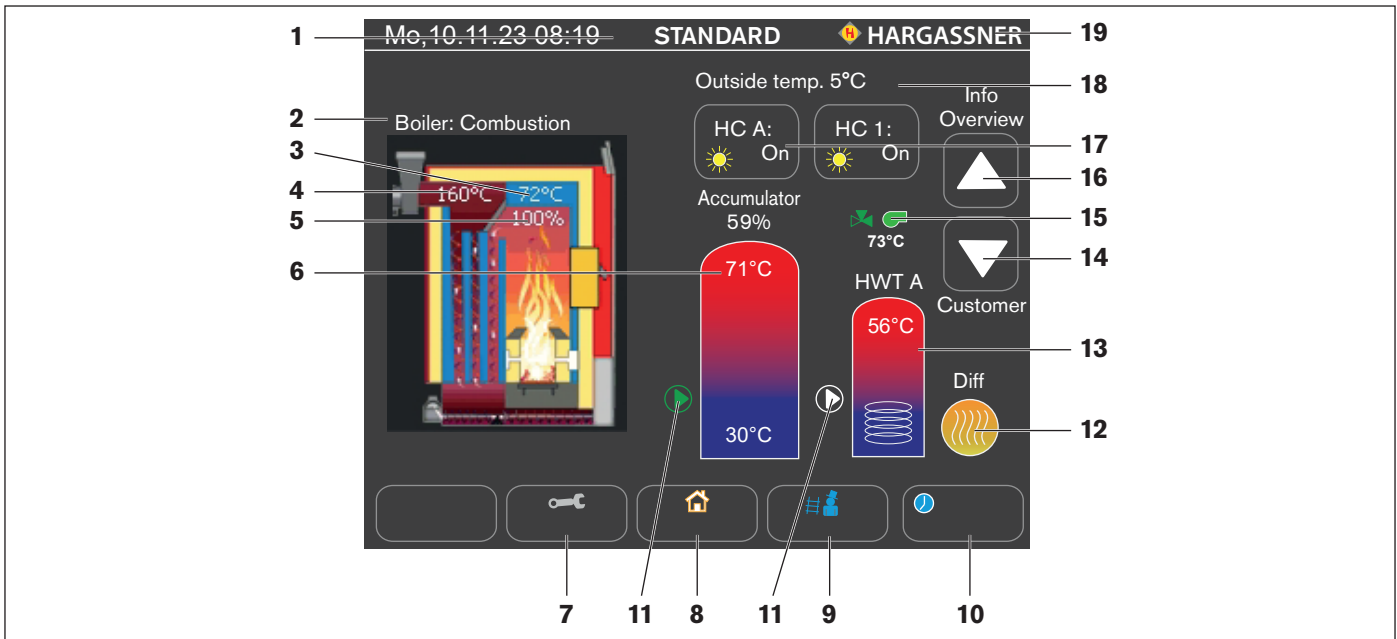

Item	Description	Function
1	Status display of the control unit Display of the current menu name	<ul style="list-style-type: none"> <li>▪ Description of the active menu</li> <li>▪ Error (flashes red) / notice (yellow)</li> <li>▪ Current position in the menu structure</li> <li>▪ <b>Boiler stop</b> in days</li> </ul>
2	Status display of the boiler	Display of the current operating status of the boiler.
3	Boiler temperature	Display of the current boiler temperature.
4	Flue gas temperature	Display of the current flue gas temperature.
5	Boiler output	Display of the current boiler temperature
6	Temperature displays of the accumulator tank Display of the filling level in %	Current accumulator temperatures (top, middle, bottom) of connected accumulator sensors. Currently filled heat capacity.
7	Settings	Switch to the menus for customer, commissioning engineer and service settings and to the control unit's setup.
8	Standard	Displays the standard menu. You can switch directly to the Standard menu from any menu. After 10 minutes without any input on the display, the display automatically switches back to the Standard menu.
9	Test mode	By pressing the test mode button, a special boiler status programme is started to measure the flue gas.
10	Function	Selection of the boiler operating mode.
11	Pump	Pump operating mode <ul style="list-style-type: none"> <li>▪ Green: Pump is running</li> <li>▪ White: Pump has stopped</li> </ul>
12	Differential control	Pressing the symbol will take you to the differential control info page.
13	Temperature display of the HWT	Display of the current water temperature in the HWT.
14	Customer	▼ Switching to the customer settings.
15	External heat boiler	Status display of external heat boiler (if available) <ul style="list-style-type: none"> <li>▪ Green: External heat boiler released</li> <li>▪ White: External heat boiler blocked</li> </ul>
16	Info	▲ Switching to the Info menu.
17	Status display of heat circuits	<ul style="list-style-type: none"> <li>▪ Off - heat circuits switched off</li> <li>▪ ☀ Sun - Heat circuits in day mode</li> <li>▪ 🌙 Moon - Heat circuits in reduced mode</li> <li>▪ ❄ Frost - Heat circuits in frost protection mode</li> </ul>
18	Display of outside temperature	Outside temperature measured with outdoor sensor.
19	Hargassner logo	Press on the logo to display the system data.

## 4 Operating modes

### Automatic



Standard mode in which the heating system is operated according to the preset temperatures and on/off times.

### Hot water (HWT)



The heating system is only used to heat up the domestic hot water, not to heat up any floor heating system or radiators.

→ Heat circuits are not controlled (except for frost protection function).

→ Pumps **Off** and mixers **Closed**

### Switch off (Off)



The heating system is switched off with the exception of the frost protection function. The touchscreen continues to show all current information.

→ Heat circuits are not controlled (except for frost protection function).

→ Pumps **Off** and mixers **Closed**

### Manual operation



Allows various actions to be carried out manually, such as manual activation of individual pumps and mixers. Also shows additional information and values.

The Standard menu view is kept in the Automatic, Hot water and OFF operating modes.

### Firing Off



Button for switching off firing. Firing can be switched off immediately or at a preset time.

→ Control of the heat circuits with the pumps and mixer continues; only firing is switched off

## 5 System status indicators

The control unit uses the temperatures and flue gas values to detect the status of the system.

### Off

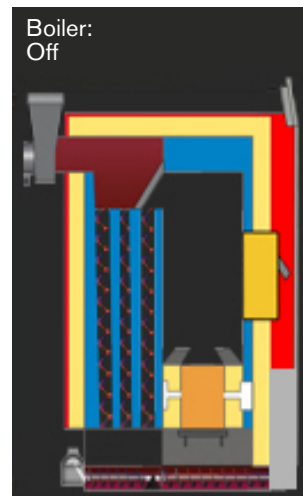

The boiler switches to the status **Off** if there is no demand from the heat circuits or HWTs or if the accumulator covers the demand.

### Ignition start

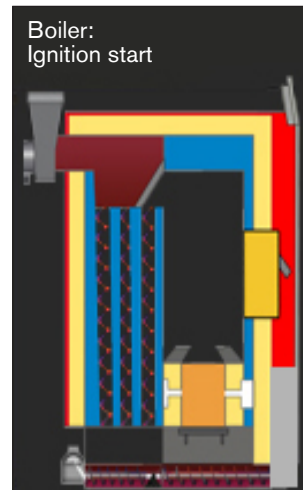

Fuel is transported into the combustion chamber and the boiler monitors if autonomous ignition occurs due to residual embers.

### Ignition



The electric ignition starts and the fuel is ignited.

## Combustion



The control unit controls the exhaust fan (air volume) according to the heat demand and required boiler temperature, and the optimum fuel amount according to the lambda sensor signal.

→ Combustion output range from 30-100%

## Burnout

The control unit regulates the burnout according to the O<sub>2</sub> content and the set minimum and maximum burnout times.

→ Primary air to 100%

→ Exhaust fan to 100%

## Slumber mode



If the heat demand drops below the minimum boiler output, the boiler switches to **slumber mode**.

## De-ash in x min



When the maximum combustion time is reached, the combustion chamber is burnt out.

## De-ash

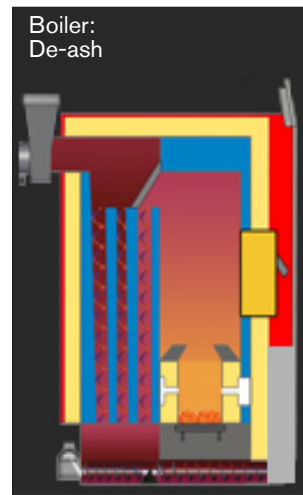

**Partial de-ash:** The intermediate grate completes one full rotation and throws the cooled ash into the ash auger. The ash is transported into the ash box and compressed there. The ash grate completes one full rotation and the turbulators clean the heat exchanger. The accumulated combustion residue falls into the intermediate grate and cools off there. The system returns to the required state afterwards.

**Complete de-ash:** All grates are opened completely and the turbulators clean the heat exchanger. The ash falls onto the ash auger and is transported and compressed in the ash box. The system returns to the required state afterwards.

## ABS Automatic blockage protection

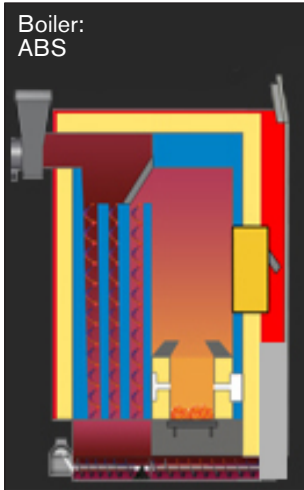

Exhaust fan, ash auger, cleaning device and ash auger system are started (duration 10 seconds). The control unit displays **caution, ABP function is starting.**

→ During the **ABP** state, do not switch off the system, do not open the system's doors or reach into the system

## 6 Flue gas measurement





The button for test mode to manually switch the system On or Off during emission tests.

The following options are available:

- **Full load:** If an accumulator is connected, press this button to have the control unit automatically change to full load measurement.
- **Empty accumulator:** Press this button to switch off all the boiler's programmed control functions. The system operates at full load, assumes very low outdoor temperatures and tries to transport as much as possible heat into the heating system. All regulating devices like thermostatic valves and automatic control valves have to be opened manually to ensure that the required amount of heat is transferred. This function ends automatically after 2 hours. If the test mode button is pressed and no accumulator is connected, the control unit offers two options: **full-load measurement** or **partial-load measurement**. All programmed control functions are switched off in the partial load measurement function. The system controls up to full load. After 15 minutes of full load, output is reduced to 50% (partial load). After 5 minutes of partial load, the message "**Start test mode measuring**" will appear on the display.

## 7 Info menu

- Press  in the Standard menu
- Use these arrows to scroll through the menu  

**Set:** Adjustment value or target value

**Actual:** Current value (position)

- In the respective Info menu, press the  symbol to go straight to the settings

### 7.1 Overview

Mo,16.05.24 08:19		HARGASSNER
Filling level	Full	
Ash-bin	OK	
Ash box	OK	
FGTM	20°C	
Heat circuit A	Reduction	
Heat circuit 1	Reduction	
Heat circuit 2	Reduction	
HWT A	Off	
HWT 1	Off	
Accumulator	Off	

Shows an overview of heat circuits, HWT and any other components of the individual heating system.

### 7.2 District line pump

Mo,16.05.24 08:19		HARGASSNER
District line pump 1		On
Pump		

If a heat circuit has a district line, the status of the district line pump is shown on this page.  
green = On, white = Off

### 7.3 External heat circuit

Mo,16.05.24 08:19		HARGASSNER
External heat circuit 1		On
Pump		On
Target temperature		60°C





If an external heat circuit is available, a corresponding info page is shown at this point.

Mo,16.05.24 08:19		HARGASSNER
External heat circuit		On
Target temp. (4.1 V)		61°C
Measuring range 100°C at 1.0 V		
Measuring range 0°C at 9.0 V		
Max. permissible temperature 75°C		

External heat circuit with active output specification.

### 7.4 Heat circuits

Shows the status of the heat circuits. One heat circuit is displayed per page. If there are several heat circuits, several info pages are available in the menu. If the mixer pump is running, this is indicated as text and by a green arrow icon.

Mo,16.05.24 08:19		HARGASSNER
Heat circuit 1	On	 1
Reduction		
Flow target	25°C	
Flow actual	25°C	 2
Pump	On	
Mixer	Off	
APP		

- Use the button next to the heat circuit (1) to call up the configuration pages
- If a FR25, FR35 or FR40 is used, it is shown in an additional line
- Select the heating mode with the heating mode button (2)

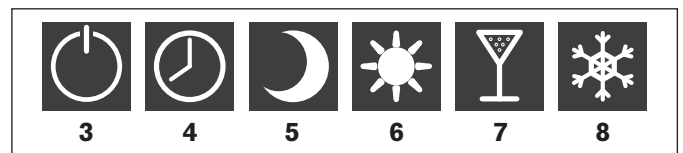

#### Off (3)

The heat circuit is switched off (except for frost protection function).

#### Automatic (4)

The heat circuit runs according to the timer programme's settings.

#### Continuous reduction (5)

The room temperature is continuously being reduced to the preset room temperature (reduction mode).

#### Continuous heating (6)

The room temperature is continuously being heated to the preset room temperature (heating mode).

#### 1x heating (7)

The heat circuit heats the room temperature to the target value (heating mode) and switches back to the automatic timer programme during the next heating cycle (or after 24 hours at the latest).

### 1x reduction (8)

The heat circuit reduces the room temperature to the target value (reduction mode) and switches back to the automatic timer programme during the next heating cycle (or after 24 hours at the latest).

## 7.5 Hot water tank

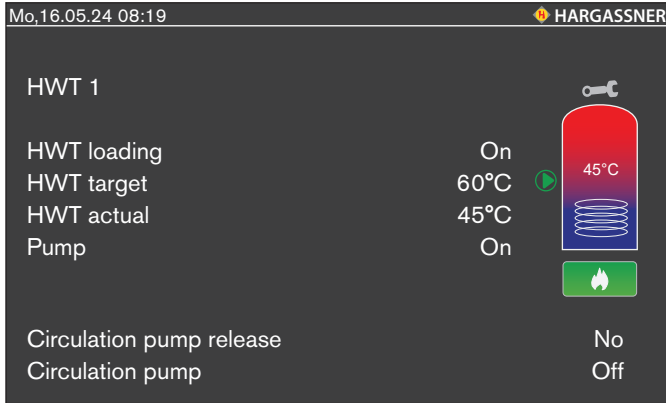

Mo,16.05.24 08:19 HARGASSNER

HWT 1

HWT loading On

HWT target 60°C

HWT actual 45°C

Pump On

Circulation pump release No

Circulation pump Off

Info page regarding the HWT status (HWT loading, target temperature, actual temperature, fill level display of the HWT and pump status). If more HWT are parametrised, more info pages are also available. The circular arrow button next to the HWT graphic shows whether the HWT pump is running or not (green = On, white = Off).

Use the HWT icon to access the HWT setting options in the configuration pages.

- **One-time charge** button 
  - Press the button to recharge the HWT once to its target temperature

## 7.6 Back-end protection

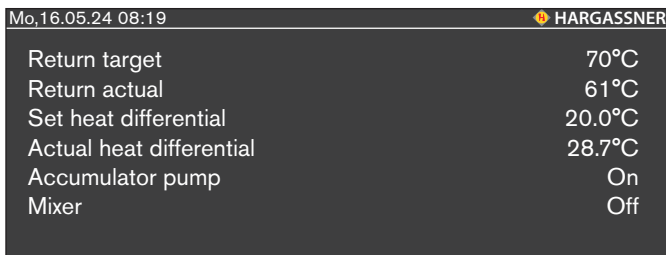

Mo,16.05.24 08:19 HARGASSNER

Return target 70°C

Return actual 61°C

Set heat differential 20.0°C

Actual heat differential 28.7°C

Accumulator pump On

Mixer Off

Info page about the current status of the back-end protection.

- Return mixer
  - **Off** - stop
  - **Open** - opens
  - **Close** - closes

## 7.7 Differential control

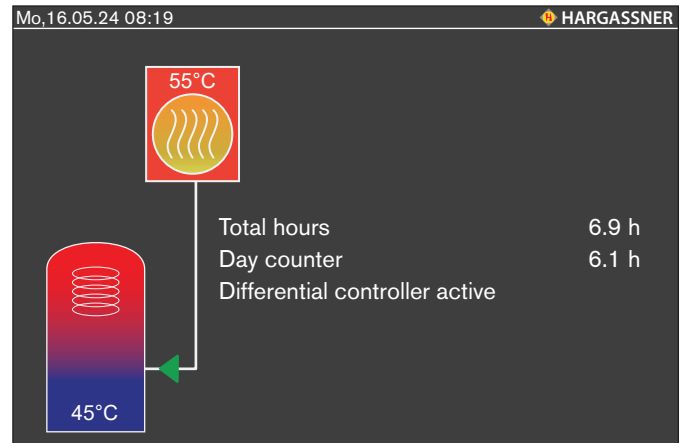

Mo,16.05.24 08:19 HARGASSNER

55°C

45°C

Total hours 6.9 h

Day counter 6.1 h

Differential controller active

Info page about the current status of the differential controller.

- Operating hours of the differential controller
- Total / day
- Current heat source temperature
- Current temperature at reference sensor (S2)

## 7.8 Boiler

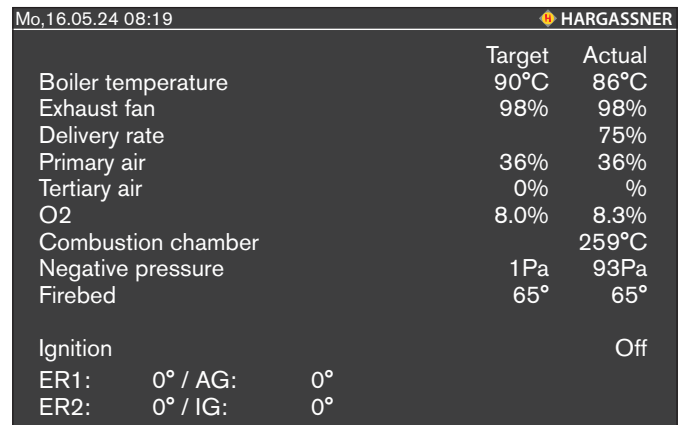

Mo,16.05.24 08:19 HARGASSNER

	Target	Actual
Boiler temperature	90°C	86°C
Exhaust fan	98%	98%
Delivery rate		75%
Primary air	36%	36%
Tertiary air	0%	%
O2	8.0%	8.3%
Combustion chamber		259°C
Negative pressure	1Pa	93Pa
Firebed	65°	65°
Ignition		Off
ER1:	0° / AG:	0°
ER2:	0° / IG:	0°

Info page about the current target and actual values of the boiler.

- Current operating status of the boiler
- Water temperature in the boiler
- Induced draft fan speed in % of maximum speed
- Current delivery rate of the stoker auger
- Position of the air flaps in % of maximum opening
- Flue gas oxygen value in % - measured on the lambda sensor
- Current temperature in the combustion chamber
- Negative pressure in pascals, measured with the negative pressure sensor
- Firebed sensor position
- Ignition active or not active
- Position of the rotary grates. Stoker grate 1 & 2, ash grate and intermediate grate

Tapping on  shows the reason for the output reduction of the boiler. The text colour provides information about the activity.

- **White:** The controller does not intervene in the output control
- **Yellow:** The controller is active, but not necessarily the reason for the output control
- **Green:** The controller is the current reason for the output control

## 7.9 Accumulator

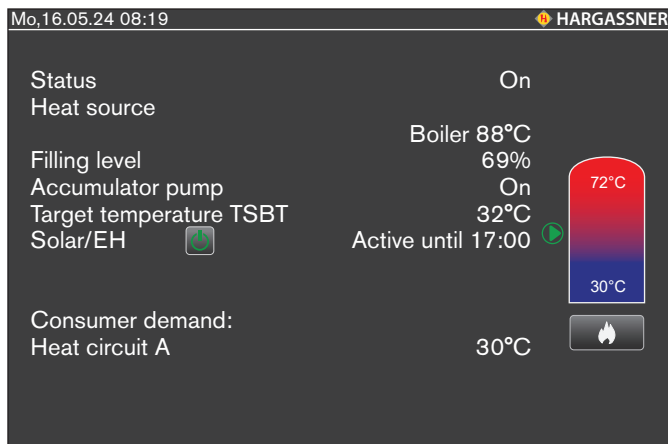

Info page about the current actual values of the accumulator.

- Filling level shows the stored heat quantity in %
  - Filling level 80% = red
  - Filling level 30% = blue
  - Filling level between 30 and 80% = blue / red
- **Solar/EH** button
  - Press the button to permanently deactivate solar or external heat operation
- **One-time charge** button
  - Press the button to recharge the HWT once to its target temperature
- The consumer demand lists the heat demand of all heat circuits and HWTs connected to the accumulator

## 7.10 External heat

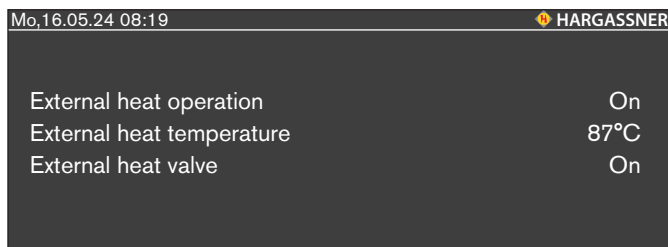

Info page about the current values of the external heat.

- External heat operation indicator
- Current external heat sensor temperature
- External heat valve indicator
- External heat pump

## 7.11 Consumption

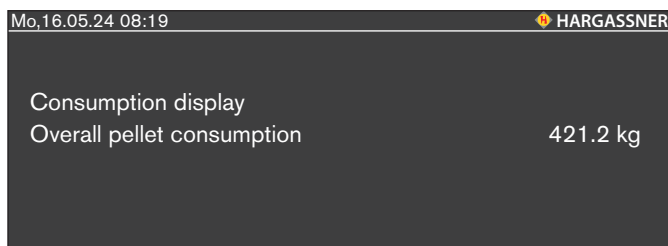

Info page about the current overall pellet consumption.

- Only displayed if the consumption display is activated in the commissioning engineer settings

## 7.12 Sensor

Info page about the measured values of all connected sensors.

## 7.13 Trend

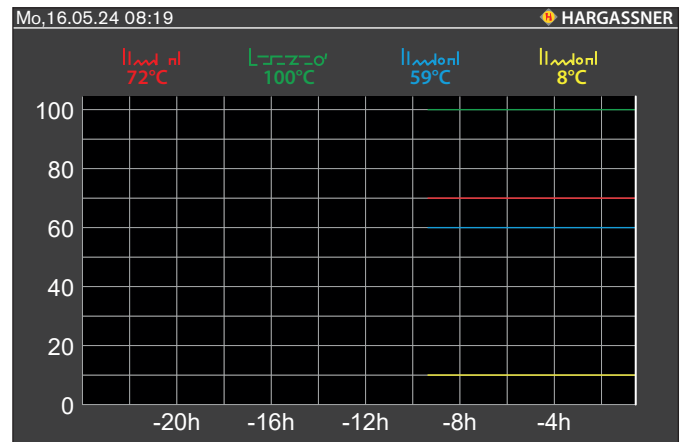
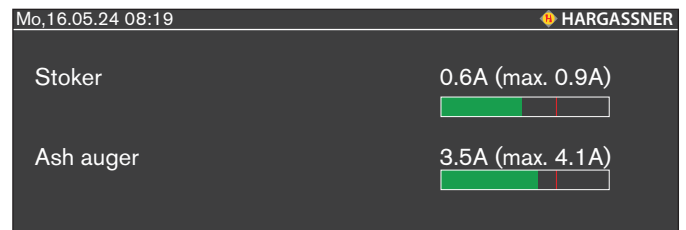

Diagram of recordings from the last 24 hours.

- Boiler temperature
- HWT temperature
- Power
- Accumulator filling level
- The timeline can be set for activated service settings

## 7.14 Electricity



List of current electricity consumption of the respective motors.

## 7.15 Counter

List of current operating hours.

## 7.16 Network

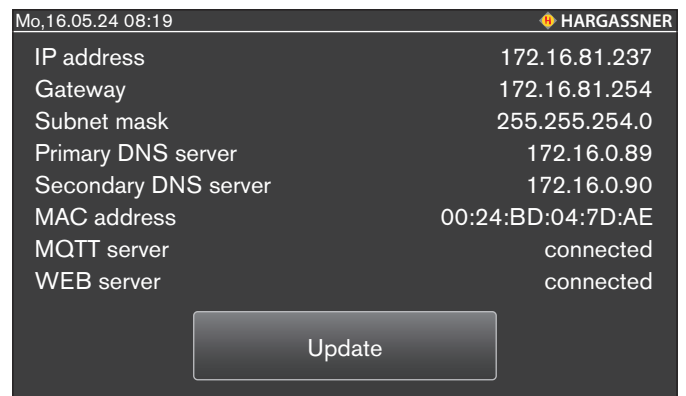

List of all important network data.

## 7.17 Web

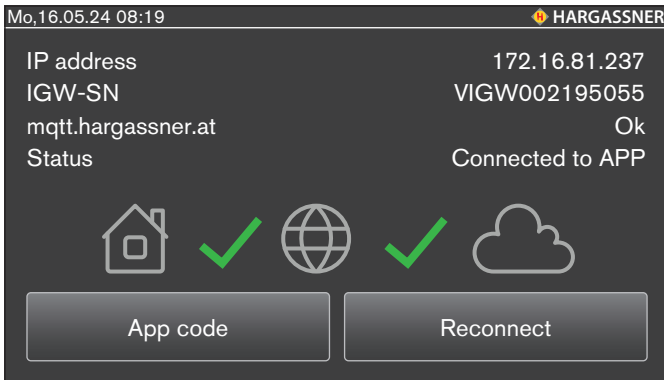

Mo, 16.05.24 08:19 HARGASSNER

IP address	172.16.81.237
IGW-SN	VIGW002195055
mqtt.hargassner.at	Ok
Status	Connected to APP

Icons: Home, Green checkmark, Globe, Green checkmark, Cloud

Buttons: App code, Reconnect

Information about IP address, VIGW number and connection status to the Hargassner server.

→ Only active if parameter Z1w is parameterised to **without Internet gateway**

Status states

- Connected to APP: Boiler is connected to the Hargassner app
- MQTT connected - idle: Boiler is only connected to the Hargassner server

Other status states are error messages.

## 7.18 Serial number

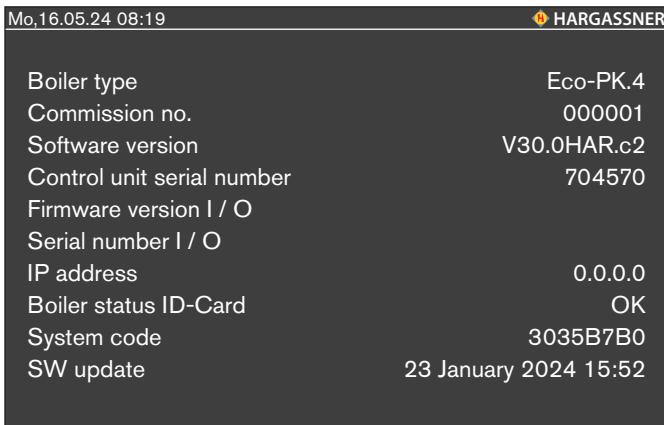

Mo, 16.05.24 08:19 HARGASSNER

Boiler type	Eco-PK.4
Commission no.	000001
Software version	V30.0HAR.c2
Control unit serial number	704570
Firmware version I / O	
Serial number I / O	
IP address	0.0.0.0
Boiler status ID-Card	OK
System code	3035B7B0
SW update	23 January 2024 15:52

Overview of the relevant system data.

## 7.19 Error

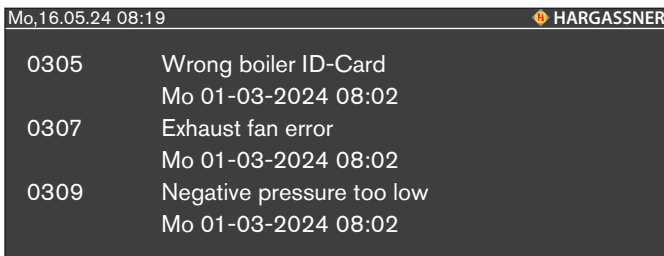

Mo, 16.05.24 08:19 HARGASSNER

0305	Wrong boiler ID-Card Mo 01-03-2024 08:02
0307	Exhaust fan error Mo 01-03-2024 08:02
0309	Negative pressure too low Mo 01-03-2024 08:02

Overview of current errors.

→ Once the fault is rectified, the error message is no longer shown

## 8 Manual operation

### WARNING

#### Risk of injury and/or material damage

##### Injuries and/or damage due to unexpected operating conditions

- When working in manual mode, limit switches and motors are not automatically monitored. Only run the augers backwards briefly (max. 2 seconds).
- Allow qualified and trained staff only to manually operate the system.

- Activate manual operation with the  button

Manual operation is used to check all the electrical functions. All drives can be controlled manually in the event of a fault or for inspection purposes.

#### Function buttons



- To activate a function, press or press and hold the button
- To deactivate the function, press again or release the button
- To activate continuous operation, (2 minutes maximum) press the button twice when the service settings are activated

### 8.1 Functions in manual operation

#### No. 1 Exhaust fan

Speed of the exhaust fan motor reached approx. 3500 rpm.

#### No. 2 Ash extraction system

Manual forward or return of the motor.

- Press Backward button only briefly

The **De-ash** button removes all ash from the ash chamber.

#### No. 2a Ash transportation system

Manual forward or return of the motor of a connected ash transportation system.

#### No. 2b Cleaning motor

#### No. 3 Fuel extraction system

Function and rotation check of fuel extraction motor. Manual forward and return of the motor to clear any blockages.

For double fuel extraction, the manual operation function **No. 3a** also appears.



#### No. 5 Stoker auger

Manual forward and return to fill the stoker auger.

- Press Backward button only briefly

For a double rotary valve, the manual operation function **No. 5a** also appears.



#### No. 5z, 6 & 6a Stoker grate

Bring stoker grate into position with the buttons . Slowly change position using active button .

The intermediate grate flap can be removed from the rotating area of the stoker grate using the button .

Press the Close grate button to bring the grate into a horizontal position.



#### No. 7 & 7a Ash grate

Bring the ash grate into position using the buttons . Slowly change position using active button .

The intermediate grate flap can be removed from the rotating area of the ash grate using the button .

Press the Close grate button to bring the grate into a horizontal position.

#### No. 7b Intermediate grate

Bring the intermediate grate into position using the buttons . Slowly change position using active button .

The intermediate grate flap can be removed from the rotating area of the ash grate using the button .

#### No. 7c Rotary grate calibration

#### No. 9 Firebed sensor

Position display and calibration of the firebed sensor.

#### No. 10 Fill combustion chamber

This function can be used to fill the combustion chamber to the ignition level. Switches off as soon as the level is reached.

#### No. 11 Ignition

Function check of ignition. After a maximum of 1 minute, the coil should be hot. After 3 minutes the ignition is switched off.

#### No. 12 Primary air flap

Function and position check of the primary air flap. At 100%, the flap is fully open.

#### No. 12a Tertiary air flap

Function and position check of the tertiary air flap. At 100%, the flap is fully open.

#### No. 13 Lambda sensor

The lambda sensor test takes approx. 5 minutes.

- Press **Test start**

After the preset period of time, a correction value must be displayed. If the value is not reached, the message "Lambda sensor defective" will be displayed.

- After the test, tighten the lambda sensor sufficiently and reinsert the flue gas sensor.

#### No. 15 Burnout

This function can be used to start a 15-minute burnout.

#### No. 16a & 16b Changeover unit

This function can be used to manually position and reference the AUP or AUE changeover unit.

#### No. 17 Pellet vacuum turbine

#### No. 18 Day hopper

This function can be used to manually start the filling of the pellet day hopper. The fill level indicator switches off the filling process automatically. The vacuum turbine can run on briefly.

#### No. 20 Return pump, accumulator pump or bypass pump

### No. 21 Return mixer

Function check or manual operation of the return mixer.

- The mixer is **Closed** when the boiler circuit is closed, and the mixer is **Open** when the return is open
- During operation, the return temperature increases when the mixer **Closes** and the return temperature decreases when the mixer **Opens**

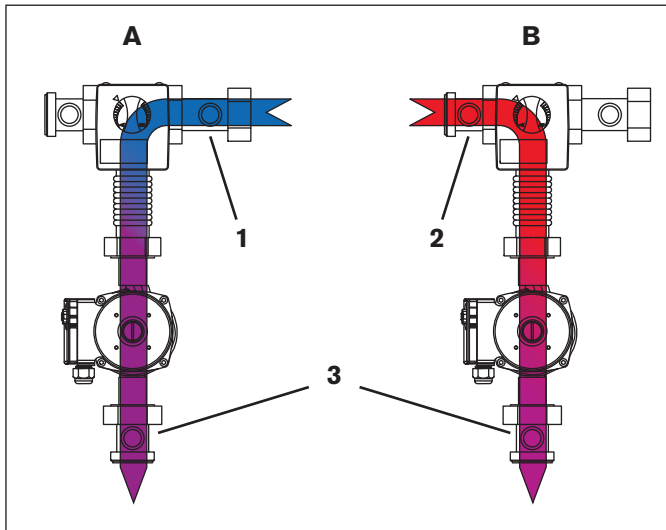

Item	Comment
<b>A</b>	Mixer open
<b>B</b>	Mixer closed
<b>1</b>	Return from the heat circuit or accumulator (blue)
<b>2</b>	Flow from boiler (red)
<b>3</b>	Return to boiler

### No. 21a Central accumulator pump

### No. 21b, 21c & 21d Additional accumulator pump

Additional accumulator connected to a heat circuit module HKM.

### No. 22 Heat circuit valve, accumulator or external heat valve

### No. 23, 24 & 24a District line pump or pump of the external heat circuit

### No. 25 Fault lamp

### No. 26 TMF horn

Acoustic warning signal for temperature monitoring in the fuel storage room.

### No. 27 & 28a Controlled district line pump

Function check or manual operation of the district line pump.

### No. 28 & 28b Controlled district line mixer

Function and rotation check of the mixer for the controlled district line.

### No. 29 Warm-air module

This function can be used to switch on the warm-air module of the PowerBox.

### No. 29a Plate heat exchanger pump

Function check or manual operation of the pump for the plate heat exchanger.

### No. 29b Plate heat exchanger mixer

Function and rotation check of the mixer for the plate heat exchanger.

### No. 30 HWT pump

Function check or manual operation of HWT pump 1.

**No. 40, 50 & 60** for HWT pump A, 2 and 3.

### No. 31 HWT circulation pump

Function check or manual operation of circulation pump on HWT 1.

**No. 41, 51 & 61** for circulation pump on HWT A, 2 and 3.

### No. 32 Heat circuit pump

Function check or manual operation of heat circuit pump 1.

**No. 34, 42, 52, 54 & 62** for heat circuit pump 2, A, 3, 4 and 5.

### No. 33 Heat circuit mixer

Function and rotation check of mixer for heat circuit 1.

**No. 35, 43, 53, 55 & 63** for heat circuit mixer 2, A, 3, 4 and 5.

### No. 36 External heat circuit pump

Function check or manual operation of the pump for external heat circuit 1.

**No. 56 & 66** for the pump for external heat circuit 2 and 3.

### No. 67 - 68k Pumps and valves for differential controller and external heat controller

### No. 68c External heat controller valve

### No. 69, 69a, 69d & 69e eCleaner

Used to adjust the eCleaner during commissioning.

- Double click on **On**
- Press **+** until the maximum value no longer changes
- Wait until U-HV has reached the set value

### No. 69m, 69n & 69o Bypass, exhaust fan and ash auger of external eCleaner

### No. 69oa, 69ob & 69oc Transport augers of the modular ash transportation system M-AFS

### No. 69od Transport auger of the ash transportation system AFS on the eCleaner

### No. 69p eCleaner cleaning motor

### No. 69q eCleaner vibration motor

### No. 70a - 70l Pumps, zone valves and circulation pumps of the freshwater stations

### No. 71 & 72 Sensor overview page

Display of the current sensor values depending on the set heating system.

### No. 80 - 80c Water quantity of freshwater station

Displays the counter for the water quantity of the freshwater station

## 9 Settings menu

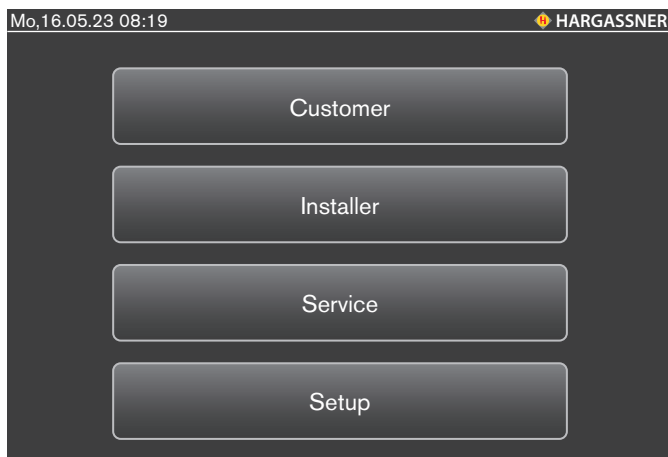

Press the **Set** button on the standard menu to access the settings menu

- Customer
- Installer
- Service
- Setup

### 9.1 Customer

This button will take you to the configuration screens, which can also be accessed from the standard menu.

⇒ „Customer settings“, p. 25

### 9.2 Installer

Permits advanced system settings and is only available to commissioning engineer and Hargassner service personnel. The individual parameter settings depend on the respective heating system configuration.

Code: 33

⇒ „Commissioning settings“, p. 29

### 9.3 Service

Allows more parameter details to be changed and is only available to service personnel. The individual parameter settings depend on the respective heating system configuration.

- Commissioning engineer and service settings are protected by a PIN code. Only service personnel can use them, as the parameters may impair the functionality of the heating system if poorly selected

## 9.4 Setup

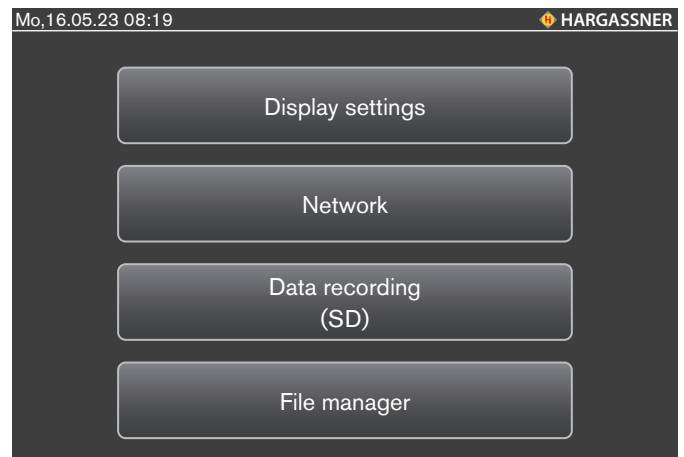

Pressing the **Setup** button in the Settings menu takes you to the Setup menu

- Display settings
- Network
- Data recording (SD)
- File manager

### 9.4.1 Display settings

#### No. 01 Display standby

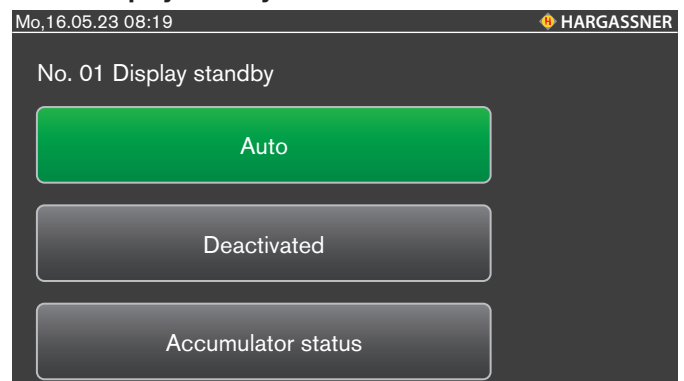

Activates or deactivates standby mode.

Accumulator status shows the current accumulator loading in standby mode

#### No. 01a Time setting for standby

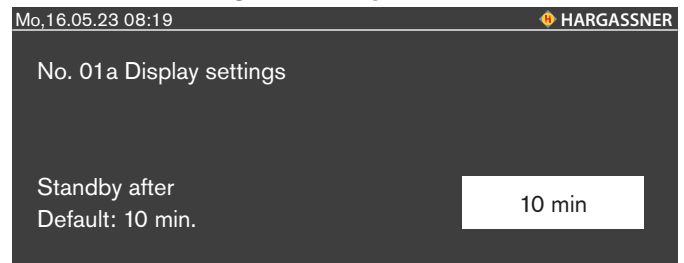

The display switches to standby mode after preset time.

#### No. 02 Time setting for home view

The display switches to the Home view after the set time.

Setting 0 deactivates this function.

#### No. 03 Backlight

Display backlight (10-100%).

### No. 03a Display lock code

Select whether a code to lock the display should be entered.

### No. 03b Display lock code

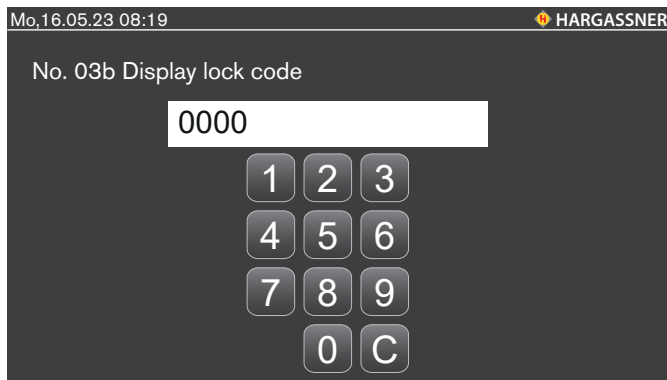

Enter 4-digit lock code.

### No. 03c Backlight if an error occurs

Backlight for an info message or error (10-100%).

#### 9.4.2 Network settings

### No. 04 Obtain IP address

Selection of whether the IP address is generated manually or automatically.

### No. 05 IP address



Manual entry of the IP address.

### No. 06 Gateway

Manual entry of the gateway.

### No. 07 Subnet Mask

Manual entry of the Subnet Mask.

### No. 08 Primary DNS server

Manual entry of the Primary DNS server.

### No. 09 Secondary DNS server

Manual entry of the secondary DNS server.

### No. 010 Display of the name of device

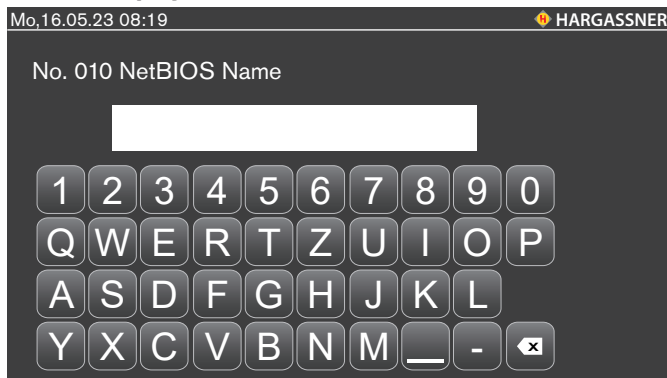

### No. 011 IP address of the KNX module

Manual entry of the IP address of the KNX module.

### No. 20-22 GSM phone number

Saved phone numbers to which the GSM module sends notifications.

→ Save phone numbers with international dialling codes

#### 9.4.3 Data recording (SD)

Additional saving of current boiler data on the SD card.

To finish the protocol, press **Stop SD logging**

#### 9.4.4 File manager

Importing and exporting data from the control unit.

- Parameter infos
- Info texts
- Languages
- Backups
- Fault lists

## 10 Customer settings

- In the Standard menu, press the **Set** and **Customer** buttons
- Select the desired setting value using **arrow buttons**
- Select the values by touching the fields highlighted in white
  - The font colour of the parameters changes to **red**
- Press the **+** and **-** buttons to set the values, the display flashes
  - Press and hold the **+** or **-** buttons to adjust the values quickly
- Confirm the set value with the green checkmark

### 10.1 HWT control

The day clock is set to weekly clock and the number of blocks is changed in the commissioning engineer settings (parameter D9 & D10).

#### No. 1 HWT 1 day timer

Setting the loading times of the HWT using the day timer.

#### No. 1a HWT 1 week timer

Setting the loading times of the boiler using the week timer.

→ Selected day = green

#### No. 2 HWT 1 target temperature

HWT loading is done only during the set loading times.

#### No. 2a HWT 1 circulation pump

Setting the switching times of the circulation pump (if available).

#### HWT temperatures according to factory settings

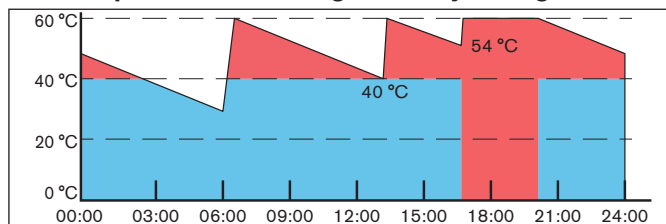

HWT loading starts as soon as the HWT temperature drops below 40 / 54°C.

## 10.2 Control of heat circuits

The day clock is set to weekly clock and the number of blocks is changed in the commissioning engineer settings (parameter D9 & D10).

#### No. 3 Heat circuit 1 day timer

Setting the heating times using the day timer.

→ The selected times are the same for all weekdays

#### No. 3a Heat circuit 1 week timer

Setting the heating times using the week timer.

### No. 4 Day room temperature

### No. 5 Reduced room temperature

Mo, 13.05.24 08:19 HARGASSNER

**Heat circuit 1**

No. 4 Day room temperature  
Default: 20.0 °C 20 °C

No. 5 Day room temperature  
Default: 16.0 °C 16 °C

Setting the desired set temperature in the room.

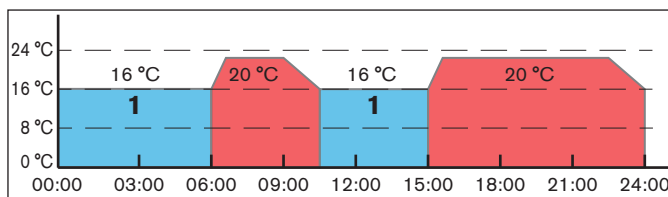

Example: On and off switching times according to factory settings for day and reduced room temperature (1).

### No. 11, 12 & 13 All heat circuits off

Mo, 13.05.24 08:19 HARGASSNER

**All heat circuits off**

No. 11 above outside temperature  
Default: 16 °C 16 °C

No. 12 above day reduction  
Default: 8 °C 8 °C

No. 13 above night reduction  
Default: -5 °C -5 °C

Setting the temperatures for the outside temperature shut-down.

#### No. 11 All heat circuits Off above outside temperature

If the average outside temperature exceeds the set value, the heat circuits will be switched off (summer shut-down).

#### No. 12 All heat circuits off during day reduction

If the average outside temperature exceeds the set value in day reduction mode, the heat circuits will be switched off.

#### No. 13 All heat circuits off during night reduction

If the average outside temperature exceeds the set value during the night reduction time, the heat circuits will be switched off.

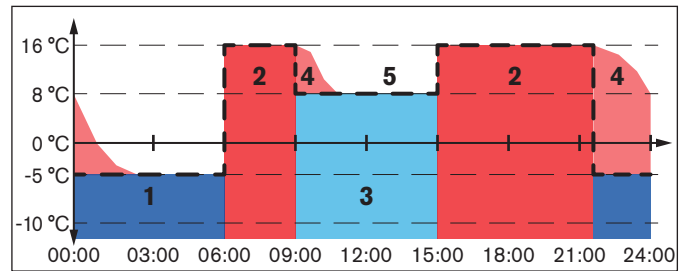

Item	Description
1	Night reduction active
2	Heating active
3	Day reduction active
4	Residual heat
5	Off

## 10.3 General settings

### Nr. 9 Filling pellets

Mo, 18.11.24 08:52 HARGASSNER

**No. 9 Automatically fill and suction times**

a. --:-- c. --:--

b. --:-- d. --:--

Setting the pellet filling times in the pellet day hopper.

### No. 15 Holiday mode

Mo, 13.05.24 08:19 HARGASSNER

**No. 15 Holiday mode**

Frost protection

Inactive

Reduction

Setting the holiday mode function.

→ Only activated if parameter D11 is set to **Yes** in the commissioning engineer settings

**No. 15a, 15b, 15c, 15d, 15e, 15f, 15g & 15h** separate holiday mode for heat circuit 1, 2, 3, 4, 5, A & B.

### No. 16 Holiday time

Mo, 13.05.24 08:19 HARGASSNER

**No. 16 Holiday time**

from Mo 14. 8. 2024 12:00

until Mo 21. 8. 2024 16:00

Setting the holiday time during which holiday mode is activated.  
**No. 16a, 16b, 16c, 16d, 16e, 16f, 16g & 16h** separate holiday mode for heat circuit 1, 2, 3, 4, 5, A & B.

### No. 18a Start de-ash

Mo, 13.05.24 08:19 HARGASSNER

**No. 18a Start de-ash**

No

Yes

Press the **Yes** button to start the de-ash and cleaning process.  
→ Only activated if parameter D50 is set to **Available** in the commissioning engineer settings

### No. 20 Date and time

Mo, 18.11.24 08:52 HARGASSNER

**No. 20 Date/time**

Mo 12. 2. 2024

08 : 19 : 30

Setting the date and time.

### No. 21b Remote control release

Mo, 13.05.24 08:19 HARGASSNER

**No. 21b Remote control release**

Inactive

Active

Defines whether the operating modes of the boiler can be controlled with the APP.

### No. 21c Locking time for the remote control

Mo, 13.05.24 08:19 HARGASSNER

**No. 21c Locking time for remote control**

Locking duration after interaction on the display

Default: 120 min. 120 Min

Defines the time after an activity on the display in which no changeover can take place via the APP. If an activity is registered on the display, the operator has no release to adjust the operating mode remotely.

### No. 22 Firing Off

Mo, 18.11.24 08:52 HARGASSNER

**No. 22 Firing Off**

Mo 20. 5. 2024

0 : 00 : 00

Used to set the date and time for when firing is switched off. The boiler remains in operating mode **Off**.

### No. 25 - 26m Heat circuit of warm-air module

⇒ See [warm-air module installation manual](#)

### No. 30 Pellet store



Current storage level in the pellet storage. If the storage level falls below the set value, the "Pellet storage level low" message is displayed.

Deviations of up to 20% possible.

→ Only activated if parameter D1f is set to **Available** in the commissioning engineer settings

### No. 40 Scheduled de-ash

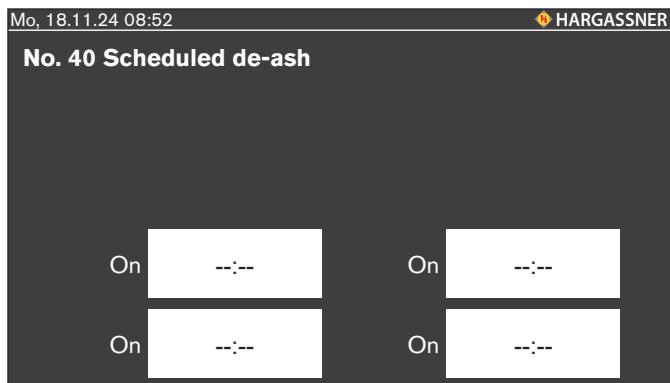

The boiler will perform a de-ash at the set time.

### No. 42 Test mode time

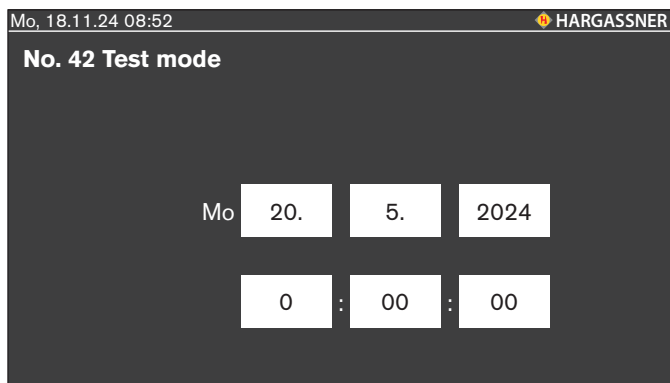

Defines the time for the test mode measurement. One hour before, the boiler is set to **Firing Off** so that the system has cooled down for the test mode measurement.

### No. 43 Test mode duration

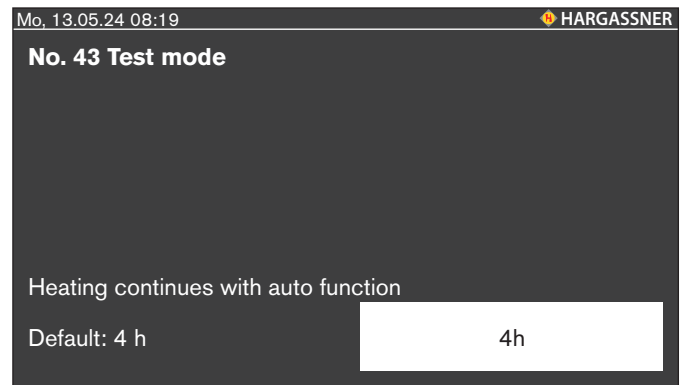

If no test mode measurement is carried out within this time, the boiler switches back to operating mode **Auto**.

# 11 Commissioning settings

- In the Standard menu, press the **Settings** and **Commissioning engineer** buttons
- Release by entering the code: 33

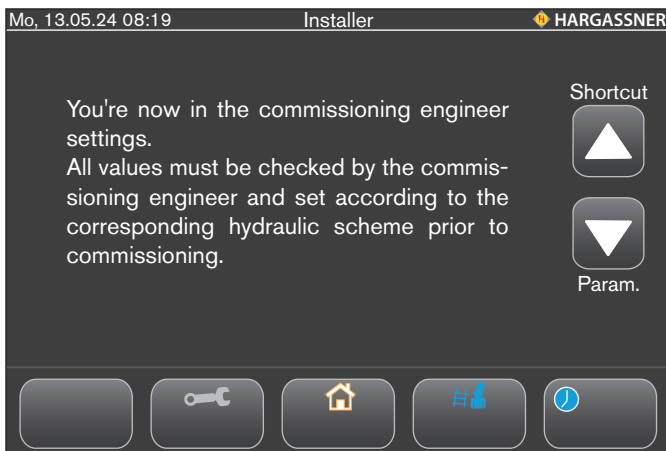

- Use the arrow key to select the desired setting values
  - ▲ Takes you straight to the parameter groups
  - ▼ Selects all parameters
- Select the values by touching the fields highlighted in white
  - The font colour of the parameters changes to red
- Press the + and - buttons to set your desired values - the display flashes
  - Press and hold the + or - buttons for quick adjustment
- Confirm the set value with the green checkmark

## 11.1 Parametrising the heat circuits and HWT

The parameters of the heat circuits, HWTs, heat circuit modules and the heat circuit board are only displayed when hardware is connected.

### Extension module 0 (HKM0)

- Heat circuit 1 (No. A1 - No. A10)
- Heat circuit 2 (No. A11 - No. A20)
- HWT 1 (No. B1 - No. B9b)

### Extension module 1 (HKM1)

- Heat circuit 3 (No. A21 - No. A30)
- Heat circuit 4 (No. A31 - No. A40)
- HWT 2 (No. B11 - No. B19b)

### Extension module 2 (HKM2)

- Heat circuit 5 (No. A41 - No. A50)
- Heat circuit 6 (No. A51 - No. A60)
- HWT 3 (No. B21 - No. B29b)

### Heat circuit board A (HC A)

- Heat circuit A (No. A61 - No. A70)
- HWT A (No. B31 - No. B39b)

### Heat circuit board B (HC B)

- Heat circuit B (No. A71 - No. A80)
- HWT B (No. B41 - No. B49b)

## 11.2 Parameter A - heat circuits

### No. A1 Heat circuit 1 version

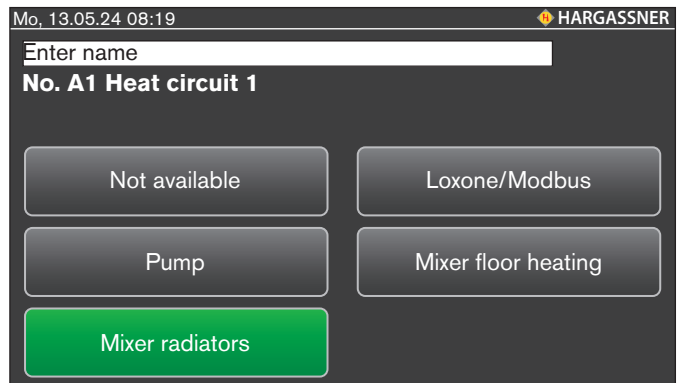

5 options:

- Heat circuit not available
- Heat circuit with pump
- Heat circuit with pump and mixer motor for radiator heat circuit
- Heat circuit control by Loxone/Modbus
  - In the event of a connection failure with Loxone, the heat circuit is operated with the emergency target temperature in parameter 10
- Heat circuit with pump and mixer motor for floor heat circuits
  - If No. A1 is set to **Not available**, No. A2 - A9 are not displayed
- Press **Enter name** to assign a different name to the heat circuit

### No. A2 Heat circuit 1 steepness heating curve

#### No. A2a Heat circuit 1 steepness heating curve of floor heating

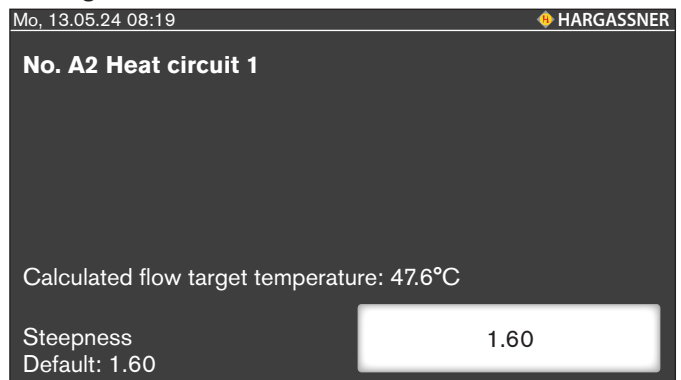

Describes the relationship between flow and outside temperatures (see heating curve).

Recommended settings:

- Floor heating: 0.3 - 1.0
- Radiator heating: 1.2 - 2.0
- Convector heating: 1.5 - 2.0
- Change in small steps only and for a longer period

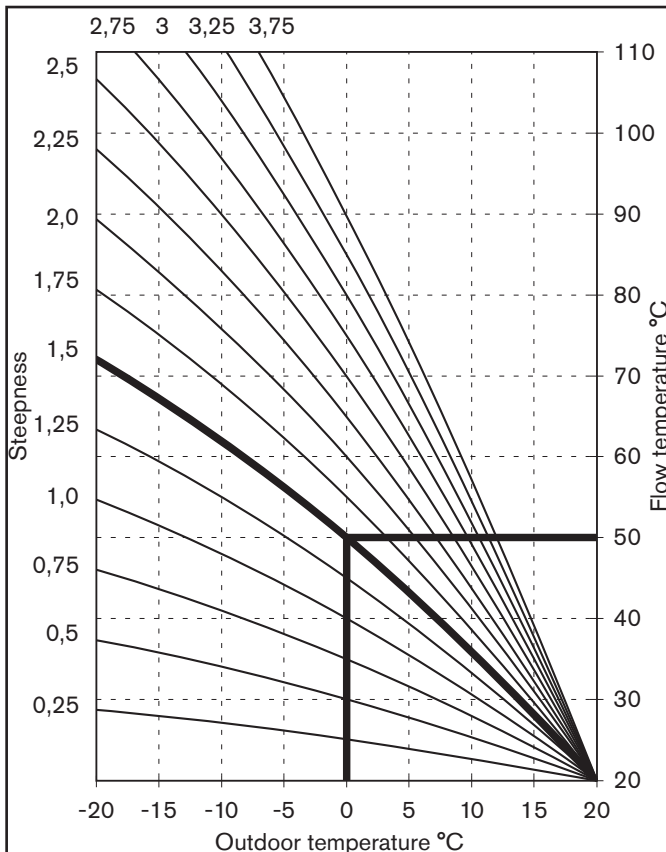

**No. A3 Heat circuit 1 flow temperature minimum**

**No. A3a Heat circuit 1 flow temperature minimum floor heating**

Minimum limit for heat circuit 1 flow temperature.  
 → This flow temperature won't be underrun in heating or reduction mode

**No. A4 Heat circuit 1 flow temperature maximum**

**No. A4a Heat circuit 1 flow temperature maximum floor heating**

Maximum limit for heat circuit 1 flow temperature.  
 → This flow temperature won't be overrun in heating or reduction mode  
 → Floor heating: Integrate an additional electromechanical thermostat which interrupts the power supply to the relevant heat circuit pump

**No. A5 Heat circuit 1 mixer runtime**

Input of the actual mixer runtime (see type plate).  
 → Duration from closed to open condition

**No. A6 Heat circuit 1 remote control**

- 5 options:
- Not available
  - Heat circuit with analogue remote control FR25
  - Heat circuit with digital remote control FR35
  - Heat circuit with digital remote control FR40
  - External switch contact at HKR or HKM
- The terminals must be closed in order to be able to start heating operation

**No. A6a, A6b and A6c Heat circuit 1 remote control with room sensor**

The remote control can be installed with or without a room sensor.

▪ Heat circuit with analogue remote control **FR25 without room sensor**

- No automatic adjustment of the room temperature
- Wiring FR25 at HKR or HKM

▪ Heat circuit with analogue remote control **FR25 with room sensor**

- Automatic adjustment of the room temperature
- Wiring FR25 at HKR or HKM

▪ Heat circuit with digital remote control **FR35 or FR40**

- If **FR35** is set, parameter **A6b** appears
- If **FR40** is set, parameter **A6c** appears

The settings made here influence what is displayed on the remote control.

**No. A6e Heat circuit 1 pump shutdown after room temperature is exceeded**

- **Deactivated:** Standard heat circuit control
- **Activated:** If the room temperature is exceeded, the heat circuit pump switches **Off** and the mixer is **Closed**

**No. A6f Heat circuit 1 input external contact**

Used to specify whether the external contact FR25 is a normally closed contact or a normally open contact

**No. A6g Heat circuit 1 room correction via app/web**

Defines whether the room correction for heat circuit 1 can be adjusted via the Hargassner app or the web portal.

**No. A7 Heat circ. 1 district line pump**

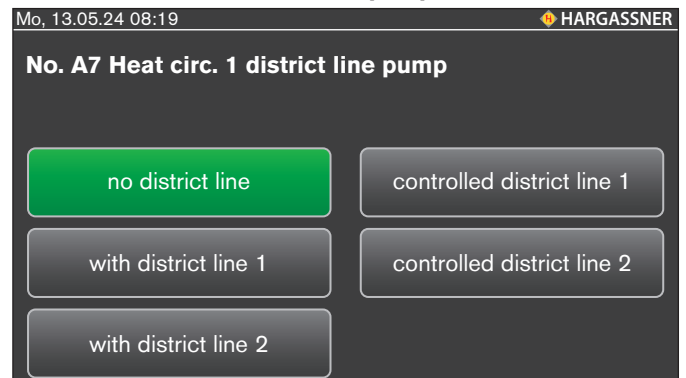

A district line transfers the temperature 1:1 to the district line network. With a controlled district line, the temperature is regulated down to a specific set temperature. The district line pump transports the hot water to the heat circuit pump and from there to the heat circuit.

**No. A8 Heat circuit 1 summer bath heating**

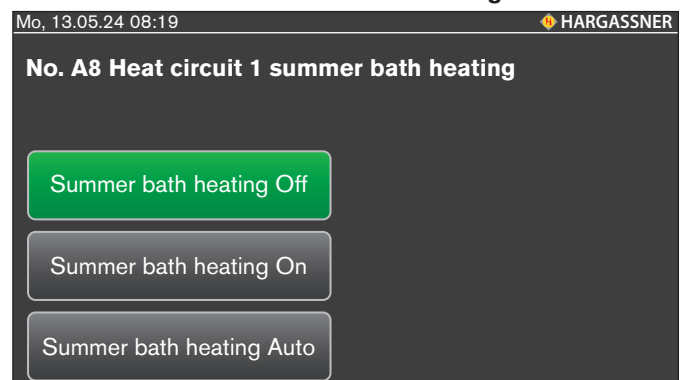

The heat circuit is activated at heating time (A8b) and supplied with temperature (A8c) until the accumulator tank has dropped to the minimum temperature (A8a). The heat circuit is then switched off.

When **On** is selected, **A8a - A8c** customer parameters appear.

→ Only works in HWT operating mode

#### No. A8a, A8b and A8c Set values of summer bath heating for accumulators

- **A8a:** Accumulator minimum temperature with setting option for 2 times
- **A8b:** Switch-on and switch-off times
- **A8c:** Flow set temperature

#### No. A9 Heat circuit 1 screed

Activation of screed dry-out function for the corresponding heat circuit. Pressing the **Heating curve** button will take you straight to parameter A100.

- When **On** is selected, customer parameters **A100 - A103** appear

#### No. A10 Heat circuit 1 Loxone connection error

Defines the temperature at which heat circuit 1 is supplied when the connection to the Loxone server is interrupted.

#### No. A11 Heat circuit 2 version

Second heat circuit

- **No. A1** and **A11** Heat circuit 1 and 2 when heat circuit module 0 is used
  - **No. A21** and **A31** Heat circuit 3 and 4 when heat circuit module 1 is used
  - **No. A41** and **A51** Heat circuit 5 and 6 when heat circuit module 2 is used
  - **No. A61** Heat circuit A when heat circuit module A is used
  - **No. A71** Heat circuit B when heat circuit module B is used
- Options: See heat circuit 1 (**A1 - A9**)

#### No. A81 Heat circuit of WLM

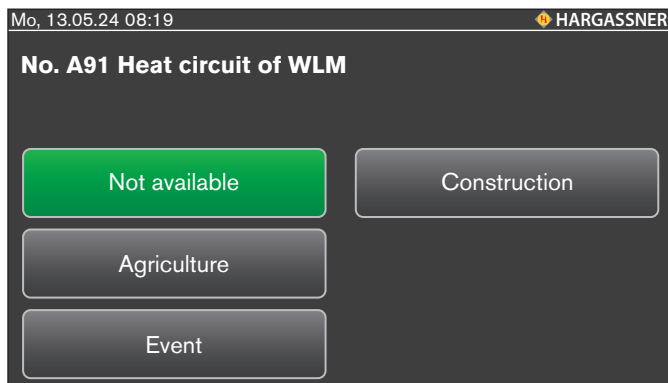

The heat source for the WLM is always a boiler or an accumulator.

- **Not available**
- **Agrar static:** Setting of a fixed speed
  - Constant air volume and temperature
- **Agrar dynamic:** Control to a fixed temperature
  - Air volume does not matter
- **Event:** Heating to room temperature
  - Heating of halls, tents, etc.

#### No. A81b - A89 Warm-air module

⇒ See warm-air module installation manual

#### No. A91 - A99 PowerBox

Options for the PowerBox. For parameter descriptions, see the operation manual for the PowerBox.

#### No. A100 Screed temperature phases

Specifies the number of phases used to increase the temperature for the screed heating process.

#### No. A101a Screed graph (all HCs)

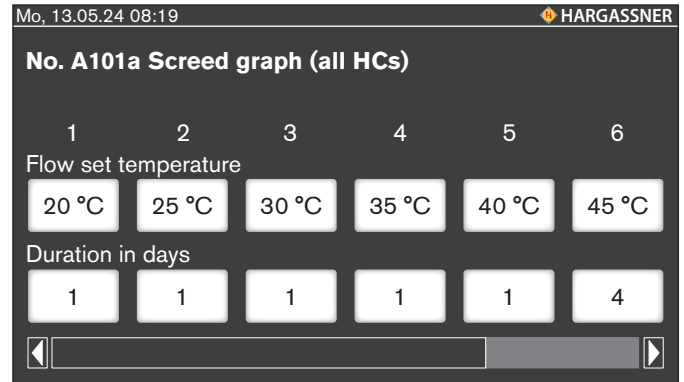

The target temperature and holding period can be specified for each phase.

#### No. A103 Screed hysteresis

If the flow temperature drops below the screed heating target temperature by this value, the timer for the holding period will be stopped and won't resume until the target value has been reached.

#### No. A110 - A111a Dry-out programme of WLM

⇒ See warm-air module installation manual

## 11.3 Parameter B - HWT

#### No. B1 HWT 1

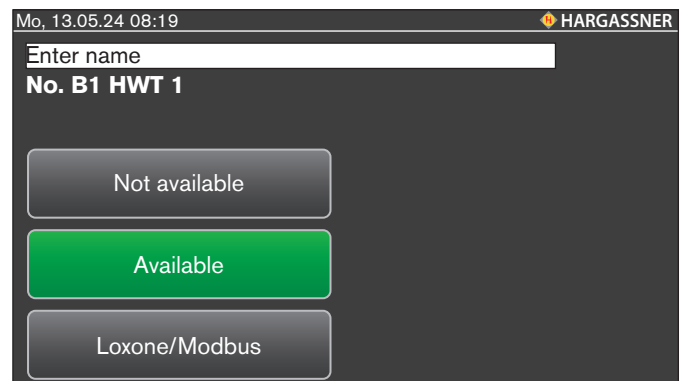

3 options:

- Not available
  - Control of HWT 1 by the Loxone Smart home control unit
  - If No. B1 is set to **Not available**, No. B2 - B9 are not displayed
- Available
  - Press on **Enter name** to name each HWT separately
- Loxone

#### No. B2 HWT 1 hysteresis

Value at which the HWT is switched on below the set minimum temperature.

#### No. B3 HWT 1 HWT temperature minimum

Lower HWT limit temperature. If the HWT temperature drops below the preset value, HWT loading starts within the set time (installer parameter no. B90) and independent of the HWT time programme (customer parameter no. 1).

#### No. B4 HWT 1 legionella protection

Legionella are bacteria that are dangerous to humans and can develop at low temperatures and in stagnant water (e.g. holiday homes). The legionella protection programme heats the hot water to a certain temperature at which legionella cannot survive.

### No. B5 HWT 1 Legionella protection target temperature

HWT target temperature for legionella protection.

- Temperatures of 70°C or above for more than 3 minutes will kill all legionella in the HWT

### No. B6 Legionella protection week programme

- Start legionella protection programme during HWT loading only

### No. B7 HWT 1 district line pump

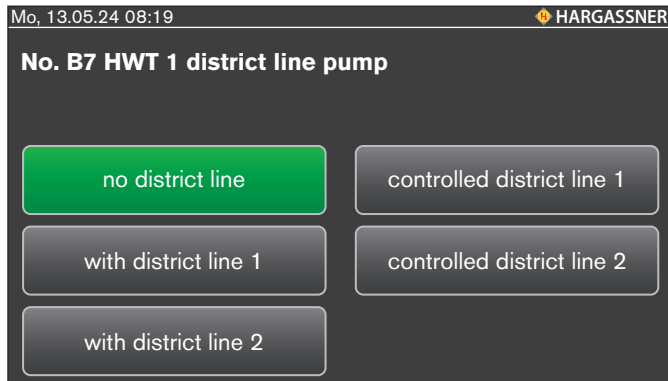

A district line transfers the temperature 1:1 to the district line network. With a controlled district line, the temperature is regulated down to a specific set temperature. The district line pump transports the hot water to the HWT pump and from there to the HWT.

### No. B8 HWT 1 circulation pump

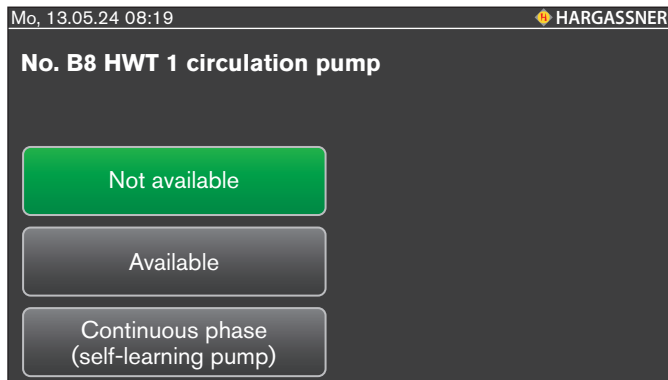

A circulation pump is a circulating pump that circulates hot water in the circulation pipe, i.e. keeps it moving.

Self-learning pumps are always controlled. They recognise independently whether it is necessary to switch on and circulate.

### No. B8a HWT 1 circulation pump runtime

The runtime depends on the length of the heating pipes and on the heat loss (insulation) in the line.

### No. B8b HWT 1 circulation pump downtime

Defines the break time for the HWT circulation pump. After this break time has elapsed, the runtime set in commissioning engineer parameter B8a begins.

### No. B9 HWT 1 energy-saving mode

- **Not activated:** The HWT is loaded in accordance with the settings in the customer parameters

- **Activated:** The HWT is loaded regardless of the loading times if the following criteria are met for the set length of time (No. B9a) before setback/reduction:

- HWT has nearly reached its minimum temperature
- Outside temperature is higher than the temperature for day reduction
- System is in lower partial-load operation (minimum output + 10%)

### No. B9a HWT 1 switch-on time of energy-saving mode

The HWT is loaded when the following criteria have been met for 30 minutes before reduction:

- Outside temperature above 16°C (customer parameter no. 5)
- HWT temperature below 50°C (commissioning engineer parameter no. B3 at 40°C + 10°C)
- Boiler output below 60%

### No. B9b HWT 1 pump runtime

Maximum pump runtime for HWT loading.

### No. B11 - B19b HWT 2

When using a heat circuit module 1

- Options: See commissioning engineer parameters **No. B1 - B9**

### No. B21 - B29b HWT 3

When using a heat circuit module 2

- Options: See commissioning engineer parameters **No. B1 - B9**

### No. B31 - B39b HWT A

When using a heat circuit board A

- Options: See commissioning engineer parameters **No. B1 - B9**

### No. B41 - B49b HWT B

When using a heat circuit board B

- Options: See commissioning engineer parameters **No. B1 - B9**

### No. B60 HWT priority operation

For quick HWT loading. For heat circuits with pumps, the heat circuit pumps are switched off throughout HTW priority operation. No heat is transferred from the system to the heat circuits. The heat circuit flow temperatures for heat circuits with mixers and pumps are reduced throughout priority operation.

### No. B90 Release HWT temperature minimum

Defines the time range in which the HWT is loaded when it falls below the minimum hot water tank temperature (commissioning engineer parameter B3) of the respective HWT. This happens independently of the respective HWT loading times from the customer settings.

## 11.3.1 Fresh-water station

### No. B106 Freshwater station 1

- Set the parameter to **Available** if a freshwater station is available

Commissioning engineer parameters **B104 - B104a** and **B106b - B108a** are only active if commissioning engineer parameter **B106** is set to **Available**.

- **B109 - B111a:** Freshwater station 2
- **B112 - B114a:** Freshwater station 3
- **B115 - B117a:** Freshwater station 4

- ⇒ To specify these settings, see the [FWS fresh-water station operation manual](#)

## 11.4 Parameter C - accumulator

### No. C1a Back-end protection

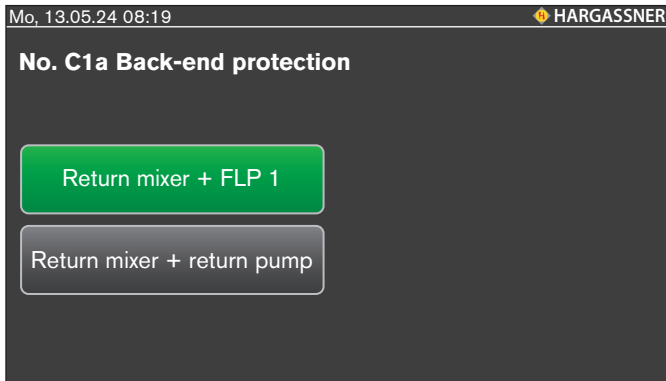

- Return mixer with district line pump 1
- Return mixer with return pump (hydraulic separator)

### No. C1b Mixer runtime of return mixer

Specifying the actual mixer runtime.

### No. C2 Central accumulator

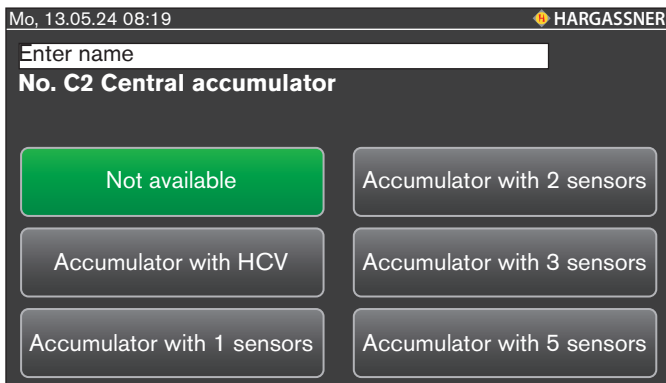

- Not available
  - Central accumulator with heat circuit valve
    - For low-temperature heat circuits, (e.g. floor or wall circuits)
  - Central accumulator with 1 sensor
    - For a hydraulic scheme with accumulator unloading control
  - Central accumulator with 2 sensors
    - For a hydraulic scheme with loading and unloading control
  - Central accumulator with 3 or 5 sensors
    - For an accumulator diagram with loading (partial-load operation) and unloading control
- Press on **Enter name** to name each accumulator separately

### No. C2a Central accumulator loading automatic

Used to specify whether the central accumulator should be loaded automatically.

### No. C2b Central accumulator volume

Used to set the central accumulator volume in litres.

### No. C2c Central accumulator filling level display

Used to specify whether the fill level of the central accumulator should be displayed in the home view, the central accumulator info page and on the screen saver.

### No. C3 Selection of hot water tank at central accumulator

- Accumulator / HWT internal (accumulator tank with integrated HWT - domestic hot water coil or external domestic hot water heat exchanger)

→ For on-site differential control between accumulator and HWT, set to **accumulator / HWT internal**

- Accumulator / HWT external (external HWT)

### No. C3a Sensor selection of central accumulator

Selection of the accumulator sensor connection:

- Accumulator sensor for boiler: Accumulator sensor will be connected to the main board
- Accumulator sensor for HKM 0 and 2: Accumulator sensor will be connected to the extension module

### No. C3b Central accumulator of internal hot water tank

Used to define which HWT is used as the internal HWT for the accumulator.

### No. C4 End central accumulator loading at temperature

Used to define the temperature, measured by the bottom accumulator sensor, above which central accumulator loading is terminated. Due to hot water preparation, the sensor selected in commissioning engineer parameter C4b is used to end accumulator loading (summer switch-off, hot water tank operation).

→ Display only when commissioning engineer parameter C2 is set with **2, 3 or 5 sensors**

### No. C4a Central accumulator boiler target temperature for accumulator loading

Used to set the minimum boiler target temperature for accumulator loading.

→ Display only when commissioning engineer parameter C2 is set with **2, 3 or 5 sensors**

### No. C4b Sensor for ending central accumulator loading

Used to define which sensor is used for the temperature measurement (commissioning engineer parameter C4) to end accumulator loading. The selected sensor is only used to end accumulator loading (summer switch-off, HWT operation) due to hot water preparation, solar or external heat operation.

→ Display only when commissioning engineer parameter C2 is set with **2, 3 or 5 sensors**

→ Display of HWT sensor only when C3 commissioning engineer parameter is set to **HWT internal**

### No. C4c Central accumulator minimum temperature

Lower accumulator limit temperature. When the accumulator temperature is below the set value (top accumulator sensor), central accumulator loading starts.

→ C4c must be at least 10°C lower than C4a

### No. C4c1 Day timer for central accumulator minimum temperature

Defines the period in which the accumulator temperature C4c is monitored.

### No. C4d Central accumulator output reduction

When the preset central accumulator fill level is reached, the system output is reduced.

### No. C4e Central accumulator error recognition for accumulator sensor

If the mixer is fully open for the set duration and the temperature difference between the bottom accumulator sensor and the return sensor is greater than 10°C, the info "Check position of bottom accumulator sensor" is displayed.

### No. C5 Week timer forced loading of central accumulator

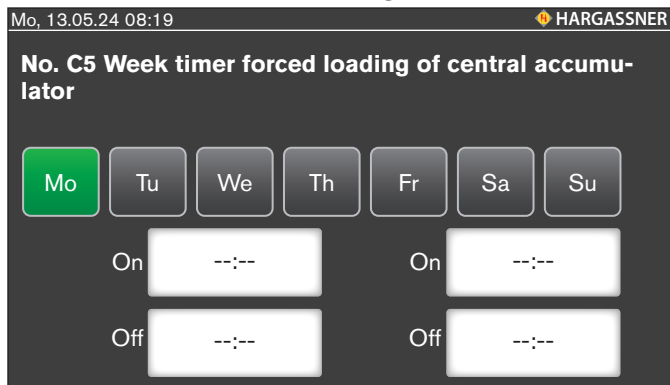

Used to set the time for central accumulator forced loading.

- Display only if parameter C2 is set to **Accumulator with 2 sensors** or **Accumulator with 3 sensors**
- Central accumulator is loaded at the set time regardless of the fill level
- E.g. for peak loads in the morning

### No. C5a No forced accumulator loading at outside temperature

No central accumulator forced loading when the set outside temperature is exceeded.

### No. C5c Boiler heat output for accumulator loading

Defines the output to which the boiler is reduced once the temperature at the top accumulator sensor has reached the requested temperature.

### No. C6 External heat circuit with analogue control

Used to define whether the external heat circuit is controlled with an analogue temperature specification or an output limit. This function is controlled via a 0-10V signal at the inputs of terminal 80/81. The temperature or output specification only takes effect if an external demand is present at the input of terminal 103/104.

**Temperature specification:** The temperatures are assigned to the electrical signal based on a characteristic curve. Example: 100°C at 1 V and 0°C at 9 V (system **Off**). Service parameter no. **M10a/b** can be used to adjust the characteristic curve for the demand or limit it via **M10c**.

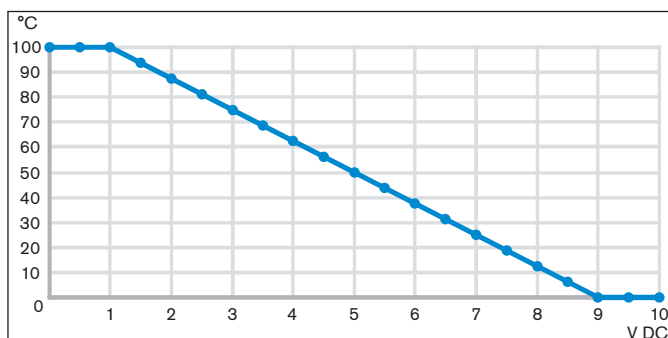

**Output limitation:** The maximum power can be limited via the analogue signal. A fixed characteristic curve limits the output within the minimum and maximum boiler output (service parameters no. **K1** and **K2**).

V DC	Boiler output in %
0	100 (K2)
0.5	100 (K2)
1	100
1.5	93.75
2	87.5
2.5	81.25
3	75
3.5	68.75
4	62.5
4.5	56.25
5	50
5.5	50 (K1)
6	50 (K1)
6.5	50 (K1)
7	50 (K1)
7.5	50 (K1)
8	50 (K1)
8.5	50 (K1)
9	50 (K1)
9.5	50 (K1)
10	50 (K1)

### No. C6a External heat circuit target temperature

Used to adjust the system set temperature for an activated external heat circuit.

- If the value is changed and parameter C7 is set to **External pump**, service parameter L5 = 50 °C must be adjusted as well
- L5 ca. 5 - 10 °C less than C6a

### No.C7 Pump output function

Used to define whether terminal 102 of the main board is used for district line pump 2 or for the pump of the external heat circuit.

- External pump
  - System is heated to the temperature set in parameter C6a
  - External heat circuit pump is switched on at release temperature (service setting L5)
- District line pump
  - District line runs when a heat circuit or HWT pump parameterised for district line is switched on

### No. C8 External heat circuit on district line pump

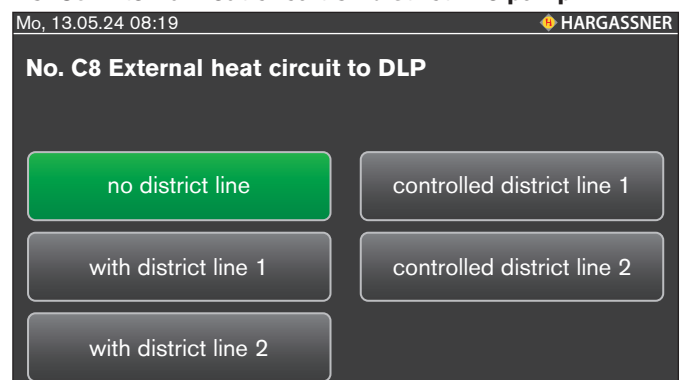

A district line transfers the temperature 1:1 to the district line network. With a controlled district line, the temperature is regulated down to a specific set temperature. The district line pump transports the hot water to the external pump and from there to the external heat circuit.

### No. C9 External heat

- Not available
- Oil or gas boiler
- Solid fuel boiler

### No. C10 Plate heat exchanger

Defines whether a system separation in the form of a plate heat exchanger is present. The consumers can be assigned to the plate heat exchanger via the CV2 parameter.

### No. C10a Plate heat exchanger mixer / secondary pump / secondary flow sensor

Defines whether a mixer (dual utilisation) is installed on the primary side and a pump and sensor are installed on the secondary side of the plate heat exchanger. The pump is activated at the same time as the boiler's return pump. These components are connected to the X10-104 board with address 2.

### No. C10b Plate heat exchanger mixer runtime

Defines the runtime of the mixer (see mixer data sheet).

### No. C10c Plate heat exchanger increase

Defines by how much the consumer demand on the plate heat exchanger is increased.

### No. C20 Additional accumulator HKM0

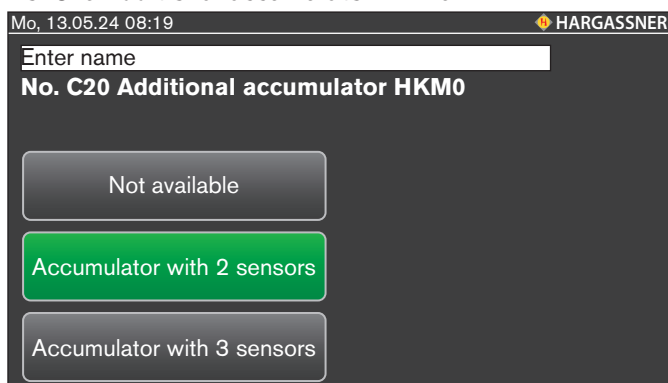

Defines whether an additional accumulator is present on heat circuit module 0 and how many sensors are used for measuring the accumulator temperature.

- Press on **Enter name** to name each accumulator separately

### No. C21e Additional accumulator volume

Used to set the additional accumulator volume in litres.

### No. C21f Additional accumulator fill level display

Used to specify whether the additional accumulator fill level should be displayed.

### No. C22 Selection of HWT on additional accumulator

- Accumulator / HWT internal (accumulator tank with integrated HWT - domestic hot water coil or external domestic hot water heat exchanger)
  - For on-site differential control between accumulator and HWT, set to **accumulator / HWT internal**
- Accumulator / HWT external (external HWT)

### No. C23 End additional accumulator loading at temperature

Used to define the temperature, measured by the bottom accumulator sensor, above which additional accumulator loading is terminated. Due to hot water preparation, the sensor selected in commissioning engineer parameter C23c is used to end accumulator loading (summer switch-off, hot water tank operation).

### No. 23a Additional accumulator heat source target temperature for accumulator loading

Used to set the minimum heat source target temperature for accumulator loading.

### No. C23b Additional accumulator loading at each boiler start

Indicates whether the accumulator is loaded when the boiler starts, although it could possibly still cover the demand.

### No. C23c Sensor for ending central accumulator loading

Used to define which sensor is used for the temperature measurement (commissioning engineer parameter C23) to end accumulator loading. The selected sensor is only used to end accumulator loading (summer switch-off, HWT operation) due to hot water preparation, solar or external heat operation.

- Display of HWT sensor only when C22 commissioning engineer parameter is set to **HWT internal**

### No. C23d Additional accumulator minimum temperature

Lower accumulator limit temperature. When the accumulator temperature is below the set value (top accumulator sensor), additional accumulator loading starts.

- C23d must be at least 10°C lower than C23a

### No. C23e Additional accumulator minimum temperature day timer

Defines the period in which the accumulator temperature C23d is monitored.

### No. C23g Additional accumulator differential control

With this function, the differential control between the central accumulator and the additional accumulator can be activated or deactivated.

### No. C24 Additional accumulator forced loading week timer

Used to set the time for central accumulator forced loading.

- Additional accumulator is loaded at the set time regardless of the fill level
- E.g. for peak loads in the morning

### No. C24a No forced accumulator loading at outside temperature

No additional accumulator forced loading when the set outside temperature is exceeded.

### No. C25 Output for pumps or zone valve for additional accumulator

Defines which output for accumulator pump or zone valve is used for the additional accumulator connected to heat circuit module 0.

### No. C26 Additional accumulator on district line

A district line transfers the temperature 1:1 to the district line network. With a controlled district line, the temperature is regulated down to a specific set temperature. The district line pump transports the hot water to the external pump and from there to the additional accumulator.

### No. C30 Additional accumulator HKM1

### No. C40 Additional accumulator HKM2

- **No. C20** when heat circuit module 0 is used
- **No. C30** when heat circuit module 1 is used
- **No. C40** when heat circuit module 2 is used

- Options: See additional accumulator HKM0 (**C20 - C26**)

## No. CV3 Consumer at the central accumulator

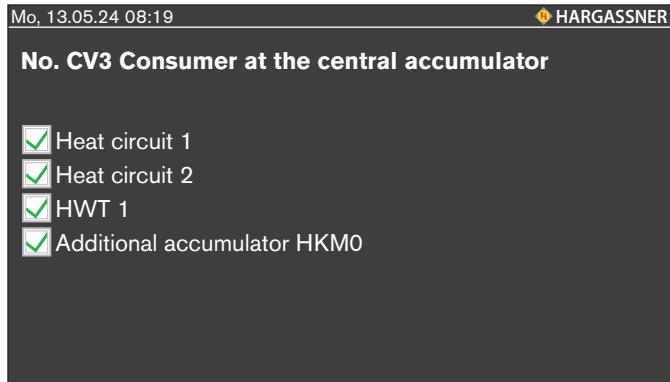

With this function, consumers can be assigned to the central accumulator.

## No. CV4 - CV6 Consumer at additional accumulator

With this function, consumers can be assigned to the additional accumulator.

- The parameters are only displayed if an additional accumulator is available
- As only 1 additional accumulator is possible, only one of these parameters is displayed at a time

## 11.5 Parameter D - general

### No. D1a - D1c Display on HKM

Selection regarding display options at connected heat circuit module.

### No. D1f Storage level display

When **Available** is selected, customer parameter No. 30 and the extended Info/consumption display info page are also enabled.

### No. D2 Frost protection

Heat circuit pumps are switched on when the value drops below the set value.

- Heat circuits with mixers are adjusted to the D3 commissioning engineer parameter temperature

### No. D3 Flow temperature with frost protection

Flow temperature when commissioning engineer parameter D2 is not reached.

### No.D4 Changeover day reduction

Changeover point at which time the outside temperature reduction logic changes from night to day settings (customer parameters 12 and 13).

### No. D5 eCleaner operation

Used to define whether the eCleaner is operated.

### No. D5c eCleaner deactivated until boiler start

Indicates which eCleaner cascade has been deactivated by the boiler because problems have occurred. The eCleaner cascade is reactivated during the next combustion.

### No. D5s De-ash release

Defines the time range in which the boiler may de-ash. During the blocking time, the boiler reduces the output if de-ash is necessary in order to be able to cover the required temperature for as long as possible.

### No. D7 Summer shutdown lock time of all heat circuits

If the outdoor temperature rises above 16°C for the duration of the set time (customer parameter no. 11), the system switches off

## No. D8 Summer time

Automatic changeover of the system clock from summer to winter time.

## No. D9 Day timer/week timer

Display of day or week timer in the customer settings.

- Day timer: Heat circuits and HWT on day timer
- Week timer: Heat circuits on week timer, HWT on day timer
- HC + HWT week timer: Heat circuits and HWT on week timer

## No. D10 Number of blocks for the week timer

Defines the number of blocks for the week timer.

## No. D11 Holiday mode released

Release so that holiday mode can be set in the customer settings.

## No. D11a Holiday mode

Used to define whether one common switch-off time can be set for all the heat circuits or whether each heat circuit has to be given its own switch-off time.

## No.D12 Outside temp. shutdown

Used to define whether the outdoor temperature switch-off is the same for all heat circuits or can be set individually for each heat circuit. By selecting **separately**, the outdoor temperature switch-off can be set individually for each heat circuit. When selecting **all HC together**, the values set in customer parameter 12 apply to all heat circuits.

## No. D13 Outdoor sensor

Used to set whether an outdoor sensor is available.

- Set to **Not available** for active, external heat circuits

## No. D20 Stoker temperature monitoring STM

Used to define whether stoker temperature monitoring is available.

## No. D21 Temperature monitoring in the fuel storage room TMF

Used to define whether temperature monitoring is available in the fuel storage room.

## No. D23 Info / Trend

Used to specify whether the graphical representation of records in the **Info / History** menu field should be shown.

## No. D23g Heat quantity

Used to define whether a heat quantity calculation is carried out via the software and displayed in the info pages.

## No. D23h Pump strength of back-end protection

Defines the pump capacity for calculating the heat quantity.

## No. D24 Modbus activated

Used to set whether a Modbus is available.

- Only visible when a Modbus ID card is inserted

## No. D25 KNX activated

Used to set whether a KNX building controller is available.

- Only visible when a KNX ID card is inserted

## No. D25a KNX transfer

Used to define the time interval at which value changes are transmitted via KNX.

## No. D25b KNX transfer of all data

If there is no value change for a longer period of time, all values are sent again after this time.

## No. D25c KNX value change

Defines how large the deviation of a value must be for it to be considered changed.

## No. D31 Operating mode of fuel extraction

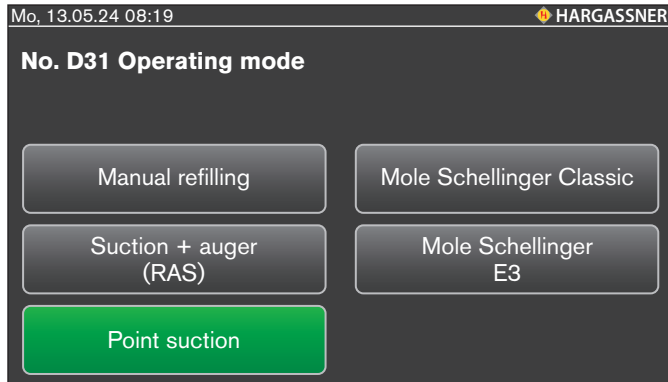

5 options:

- Manual filling: Day hopper is filled by hand
- Suction and auger (RAS): Day hopper is filled automatically via auger and vacuum turbine
- Point extraction: Day hopper is automatically filled by point extraction
- Maulwurf Schellinger Classic and E3: Day hopper is filled automatically by Schellinger external extraction system

### No. D31a Changeover unit for feeding wood pellets

Used to set whether a changeover unit is available and how many suction points it has.

### No. D31b Position change of changeover unit

Used to define after how many days the changeover unit should change position.

### No. D31c Set the changeover unit's system

- Belimo (AUE)
- Step motor (AUP)

### No. D31e First suction process after filling the storage room

Used to define the first suction point after filling the storage room. After filling the storage room, the system starts at the current or first possible suction point according to this setting. The storage room can therefore always be emptied from one side.

### No. D32 Controlled district line 1

Used to define the heat source super-elevation when the controlled district line pump is switched on.

### No. D33 Controlled district line mixer runtime

Used to define the mixer runtime of the controlled district line from closed to open state.

### No. D34 - D35 Controlled district line 2

→ Options: See controlled district line 1 (D32 - D33)

### No. D40b Storage room switch start behaviour

Defines the start-up behaviour of the boiler when the storage room switch was active.

- Manual: Fault on the boiler must be acknowledged manually so that the boiler can start again
- Automatic: If the contact of the storage room switch is closed, the fault is also acknowledged automatically and the boiler can start again

## No. D41 Text1 external error

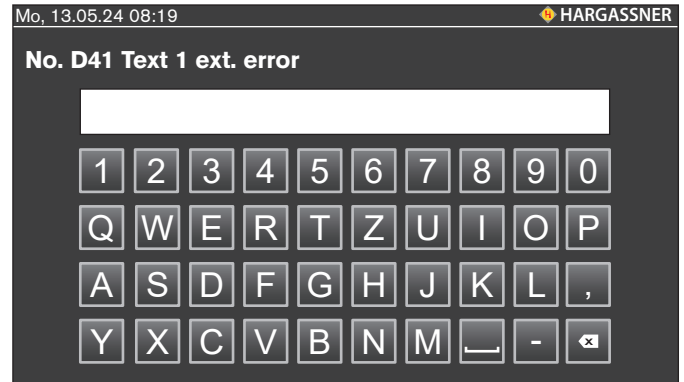

Text of the external error shown on the display.

### No. D42 Text2 external error

Text of the external error shown on the display.

### No. D42a Input external error

Used to set whether the external input is normally closed or normally open.

### No. D43 - D44a External info

→ Options: See external error (D41 - D42a)

### No. D45 System pressure monitoring

Used to define whether system pressure monitoring is available on the boiler.

### No. D45a Info when the water pressure falls below

Used to define the water pressure below which an info is issued.

### No. D45b Error when the water pressure falls below

Used to define the water pressure below which an error is issued.

### No. D45c Info when the water pressure is exceeded

Used to define the water pressure above which an info is issued.

### No. D45c Error when the water pressure is exceeded

Used to define the water pressure above which an error is issued.

### No. D50 Customer manual de-ash

Used to set whether de-ash can be carried out manually by the customer (customer setting No. 18a).

### No. D51 Customer scheduled de-ash

Used to define whether the customer can set a scheduled de-ash (customer setting No. 40).

### No. D65 Error output

Used to set whether the error output will emit a signal with info messages and errors or just with errors (terminal 97).

### No. D66 Heat circuit and HWT on the standard screen

Used to select which heat circuits and HWTs will be displayed in the standard menu.

### No. D71 Pump on for frost protection

Selection of the pumps that are active during frost protection.

## No. D73 Frost protection



If the system is in frost protection and the boiler temperature or return temperature falls below this value, the return mixer is opened and the selected pumps (D71) are switched on.

## No. D75 Function of terminals 52 and 53

Defines the function of terminals 52/53. The standard is the flue gas temperature monitor **FGTM**. Optionally, the input can be used for an external stoppage.

## No. D75a Block text

Text of the info shown on the display when an external stoppage is active.

## No. D80 Accumulator solar or external heat operation

This function is used to enable solar or external heat operation. Solar or external heat operation is active for the period set in commissioning engineer parameter D80a. During this time, loading only takes place up to the accumulator sensor set in commissioning engineer parameter C4b.

## No. D80a Enable time for solar or external heat operation

Used to define the period during which solar or external heat operation is active.

## No. D80b Temperature dropped below during solar or external heat operation

Used to define how far the heat circuit demand may be undercut in solar or external heat operation. If the temperature falls below the release temperature of the heat circuit pumps beforehand, accumulator loading is started as soon as the heat circuit pumps are switched off.

## No. D80c Accumulator loading for solar or external heat operation

Used to define after how many combustions shorter than 30 minutes the accumulator is fully loaded.

## 11.6 Parameter E - languages

### No. E1 Language

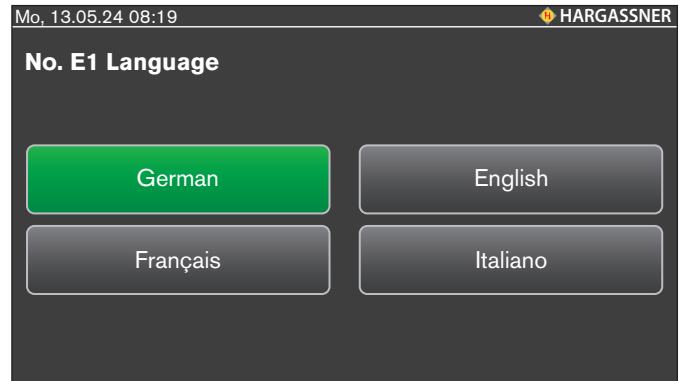

Language selection.

## 11.7 Parameter F - cascade

⇒ To specify these settings, see the [cascade control or the cascade manager operation manual](#)

## 11.8 Parameter G - differential control

### No. G1 Differential controller function

Used to define whether the differential controller is used for solar control with 1 or 2 circuits or for the return control of an external heat boiler.

### No.G2 Differential controller switch-on temp.

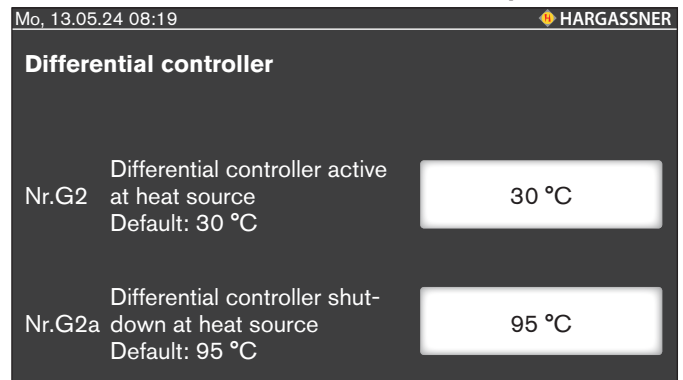

Used to set the temperature the heat source sensor has to reach for differential controller to start regulating.

### No.G2a Differential contr. switch-off temp.

Used to set the temperature the heat source sensor has to reach for differential controller to stop regulating.

→ Differential controller shutdown to protect system

### No. G2b Differential controller's switch-on temperature

Used to set the temperature the heat source sensor has to reach for differential controller to start regulating.

→ Only activated if G1 is on **External heat boiler**

### No. G2c Differential controller release time

Defines the release time of the differential controller. Outside of this time, the differential controller is not in operation.

## No. G4 Circuit 1 (priority circuit) sensor selection

Used to set which sensor is used for differential control.

- I/O36 terminal 209/210: Sensor S2 on the I/O36 board
- Top central accumulator sensor
- Center central accumulator sensor
- Bottom central accumulator sensor
- TSCT central accumulator sensor: Top centre accumulator temperature sensor
- TSCB central accumulator sensor: Bottom centre accumulator temperature sensor
- HWT sensor
- Top additional accumulator sensor
- Centre additional accumulator sensor
- Bottom additional accumulator sensor

→ The temperature will be determined using the heat source sensor and the sensor selected here

## No. G4a Superelevation of heat source

Used to set the increase for the heat source.

If the heat source exceeds the first circuit's temperature plus the superelevation specified here, the pump will be activated.

## No. G4b Circuit 1 hysteresis

Used to set the heat source's differential gap.

If the heat source drops below the circuit's temperature plus the increase minus the differential gap specified here, the pump will be switched off.

## No. G4c Circuit 1 shutdown

Used to set the shutdown temperature for circuit 1.

If circuit 1 reaches this shutdown temperature, the pump will be switched off.

## Nos. G5 - G5c Circuit 2

Same settings as G4 - G4c.

## No. G5d Circuit 1 and 2 parallel operation

Definition of parallel operation of the two circuits.

- No (no valve available): Pumps for two circuits will not run simultaneously
  - No (valve available): A changeover valve will switch between two circuits
    - Only one pump is being used for both circuits
  - Yes: The pumps for both circuits can be actuated at the same time
- For two-circuit operation with a pump and a changeover valve, select **No (valve available)**

## No. G5e Temp. difference for changeovers to circuit 2

Specify temp. differ. betw. circuit 1 and heat source dictating if changeover to circuit 2 occurs.

If this temperature difference is dropped below, the controller will switch to circuit 2 after the period specified in G5g.

## No.G5f Temperature for changeovers to circuit 2

Used to define the temperature of the first circuit from which the system switches to the second circuit.

## No. G5g Time delay for changeovers to circuit 2

Used to set the time delay for changeovers to circuit 2.

If G5e and G5f are fulfilled in this period, the controller will switch to circuit 2.

## No. G6 External heat boiler switch-on

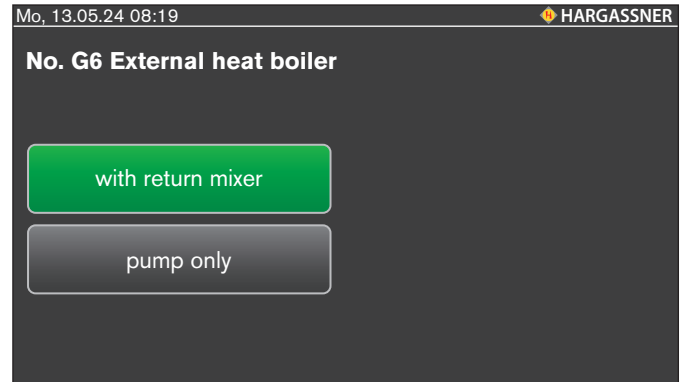

- With return mixer: Temperature is controlled via a mixer
- Only pump: The temperature must be controlled by switching the pump on and off
  - Only active if G1 is on External heat boiler
  - Return temperature regulated by sensor specified in G6e

## No. G6a External heat boiler mixer runtime

Used to define the mixer runtime of the external heat boiler from closed to open state (for an external heat boiler with return mixer).

## No. G6b External heat boiler return temp.

Return temperature of heat source according to the manufacturer.

## No. G6c Message if external heat boiler return temp. is not reached

Set the return temperature the external heat boiler has to drop below for a message to be issued.

## No.G6d Period ext. heat boiler message

Used to specify how long the external heat boiler's return temperature has to be below the temperature specified in G6c for a message to be issued.

## No. G6e Reference sensor selection for external heat boiler

Used to set which sensor is used for differential control.

- Top central accumulator sensor
  - Center central accumulator sensor
  - Bottom central accumulator sensor
  - TSCT central accumulator sensor: Top centre accumulator temperature sensor
  - TSCB central accumulator sensor: Bottom centre accumulator temperature sensor
  - HWT sensor
  - Top additional accumulator sensor
  - Centre additional accumulator sensor
  - Bottom additional accumulator sensor
- The temperature will be determined using the heat source sensor and the sensor selected here

## No. G6f Superelevation of heat source

Used to set from which temperature increase the differential controller is activated.

If external heat boiler exceeds the circuit's temperature plus superelevation specified here, the pump will be activated.

## No. G6g External heat boiler hysteresis

Used to set the differential gap of the external heat boiler.

If the external heat boiler drops below the circuit's temperature plus the increase minus the differential gap specified here, the pump will be switched off.

### **No. G7 Safety contro**

Used to set the maximum temperature for the external heat boiler. If the external heat boiler exceeds this temperature, pump will be activated or remain activated and mixer will open.

### **No. G8 Differential controller heat meter**

Defines whether a heat quantity calculation for the differential controller is carried out via the software.

### **No. G8b, G8d and G8f Pump output**

Used to define the pump output of pumps 1-3 for calculating the heat quantity.

### **No. G8g Carrier medium heat capacity**

Defines the heat capacity of the carrier medium.

Reference values:

- Water: 1.163 Wh/kgK
- Water/glycol 30%: 1.098 Wh/kgK
- Water/glycol 45%: 1.023 Wh/kgK

### **No. G9 Differential controller defrost function**

A defrost function for the solar panels can be activated in the differential controller info page. If this function is activated, the corresponding pumps run for the duration set in commissioning engineer parameter G9a.

### **No. G9a Differential controller defrost function duration**

Defines the runtime of the pumps for the defrost function.

### **Nos. G11 - G17 External heat controller 2**

→ Same settings as G1 - G7

### **No. G19 - G19a External heat controller defrost function**

→ Same settings as G9 - G9a

### **Nos. G21 - G28g PWM diff. controller**

⇒ [See installation manual for S additional board](#)

## 12 Optional remote controls

Using a remote control makes it easy to adjust the room temperature and also the heating and setback settings. The heating temperatures and times can be set and changed with the FR35 and FR40 digital remote controls. One heat circuit may be parametrised per remote control, with or without using room temperature.

- 1 heat circuit on the extension board
  - HC A/B board only digital remote control
- 2 heat circuits per heat circuit module
  - HKM 1-2
- 2 heat circuits per heat circuit controller
  - HKR 0-15

### 12.1 Digital remote control FR40

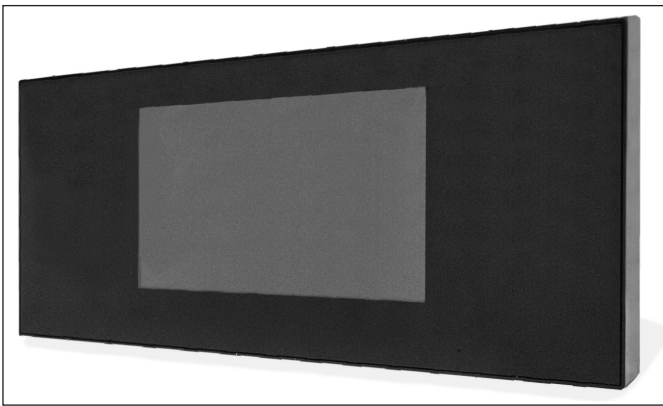

With the FR40, all the heat circuit functions available on the boiler can be set from wherever the remote control is in the user's living space.

#### Operating states

##### • Off



The heat circuit is switched off (except for frost protection).

##### • Automatic



The heat circuit is operated according to set times.

##### • Permanent reduction (in automatic mode)



The heat circuit is in permanent reduced mode.

##### • Permanent heating (in automatic mode)



The heat circuit is in permanent heating mode.

##### • 1x heating (heating on a single occasion)



The heat circuit switches to permanent heating mode on a single occasion and automatically reverts to automatic mode at the next preset heating time.

##### • 1x reduction (reduction on a single occasion)



The heat circuit switches to permanent reduced mode on a single occasion and automatically reverts to automatic mode at the next preset heating time.

#### Fine adjustment of room temperature



Increase of up to 3°C.



Decrease of up to 3°C.

### 12.2 Digital remote control FR35



The remote control is also available in a wireless version. Different selection options are available on the remote control only when the system is in **Automatic** mode.

- Selection of the heat circuit's operating mode
- Selection of the display on the remote control

#### Operating states

##### • Off



The heat circuit is switched off (except for frost protection).

• **Automatic**



The heat circuit is operated according to set times.

• **Permanent reduction** (in automatic mode)



The heat circuit is in permanent reduced mode.

• **Permanent heating** (in automatic mode)



The heat circuit is in permanent heating mode.

• **1x heating** (heating on a single occasion)



The heat circuit switches to permanent heating mode on a single occasion and automatically reverts to automatic mode at the next preset heating time.

• **1x reduction** (reduction on a single occasion)



The heat circuit switches to permanent reduced mode on a single occasion and automatically reverts to automatic mode at the next preset heating time.

**Fine adjustment of room temperature**



Increase of 2 to 3°C.



Decrease of 2 to 3°C.

**Fault lamp**



Lights up if an error occurs on the boiler.

**Display parameters**

Selection on commissioning engineer parameter A6b of which temperature is displayed on the remote control.

## 12.3 Analogue remote control FR25



Only for HKM or HKR heat circuits.

Different selection options are available on the remote control when the system is in Automatic mode .

**Operating states**

Selection of the operating status of the heat circuit with the rocker switch.

• **Continuous reduction**



The heat circuit switches to permanent reduced mode.

• **Automatic**



The heat circuit switches to day or week mode.

• **Continuous heating**



The heat circuit switches to permanent heating mode.

**Fine adjustment of room temperature**

Fine adjustment of the room temperature with the rotary knob. Increase / decrease by 2 or 3°C.

**Fault lamp**



Lights up if an error occurs on the boiler.

## Chapter IV: Cleaning

### DANGER

#### Risk of injury

##### Risk of crushing and amputation due to moving parts

- Refrain from accessing augers or motors when the system is switched on.
- Fix and lock the ash container on the system correctly.
- Do not work on the system while people are in the danger zone. Secure and lock storage room.
- Only clean the augers and remove blockages using suitable tools and when the system is switched off.
- Wear safety shoes.
- Observe the storage room sticker.

### DANGER

#### Danger to life

##### Electric shock from contact with live terminals

- Observe information signs.
- Disconnect the power supply prior to any cleaning or work.
- Check that no voltage is present using a voltmeter.
- Switch off the system and secure it against restarting.

### DANGER

#### Risk of injury

##### Risk of crushing or injuries from reaching into the danger zone during recommissioning

- While working on the system, switch off the main power switch, lock it using a padlock and carry the key with you for the duration of any work.
- After triggering main power switch, do not reach into the danger zone without thinking.
- Hand out the key for a lock to the authorised person only.
- Rectify error.
- When recommissioning, check that nobody is in the danger zone or storage room.

### DANGER

#### Risk of fire, explosion

##### Risk of burning from inflammable materials

- Do not spray any inflammable sprays on hot surfaces (e.g. lubricating moving parts in the combustion chamber). Spray drops can cause explosive fire.
- Do not use any inflammable lubricants.
- Allow system (combustion chamber) to cool down.

##### Fire in the vacuum cleaner sack

- Let the ash cool down prior to vacuum cleaning.

### CAUTION

#### Material damage

##### Formation of dust due to system leakages

- Clean sealing surfaces with industrial alcohol and a dry and soft cloth only.
- Make sure the cleaning agent has evaporated before commissioning.

### CAUTION

#### Material damage

##### Dirt, boiler breakdown due to escaping ash when overfilling the ash container

- Regularly empty and clean the ash container.
- Properly position and close the ash container.

- Small cracks may occur in the refractory in regular operation. These are stress cracks that form an expansion joint. This cracking is important and does not lead to any functional impairment. Hence there is also no claim under warranty.
- The specified cleaning and maintenance intervals are absolutely necessary for safe and clean operation of the system. Observe the state regulations and resulting chimney sweep's inspection and sweeping intervals dictated by these regulations.

## 1 Maintenance contract

If you sign a maintenance contract with Hargassner Ges mbH, the annual cleaning and maintenance takes place during the annual service performed by personnel authorised by Hargassner. Service must be carried out regularly by the manufacturer (every one to three years) depending on your country's regulations. This service must be carried out by the manufacturer or by trained and authorised individuals.

- To ensure optimum operation of the system, extensive cleaning of the system is required
  - At least once a year
  - After a set number of operating hours in the event of an error
- The cleaning intervals will change or shorten depending on the composition of the fuel and if low-grade material is used

## 2 Weekly/monthly cleaning

### 2.1 Weekly intervals

- Carry out a visual check of the entire system, including the fuel storage chamber, once a week
  - Rectify identified defects immediately
- Empty ash box **(1)** if required

**i NOTE**

Dispose of any ash in accordance with the respective country's regulations. When using harmless fuels, the ash can be regarded as a high-quality mineral fertiliser and can be used for composting. Watch out for ember pockets.

### 2.2 Monthly intervals

- ⇒ See "Monthly checks" in the commissioning book
- Check the safety devices **(2)**
  - This may be waived if an annual inspection is performed by the manufacturer
- ⇒ „Maintenance contract“, p. 43
- Check the flue pipe **(3)**
- Ensuring proper condition of the boiler room
- Readiness of portable fire extinguishers
- Ensuring proper storage of ash

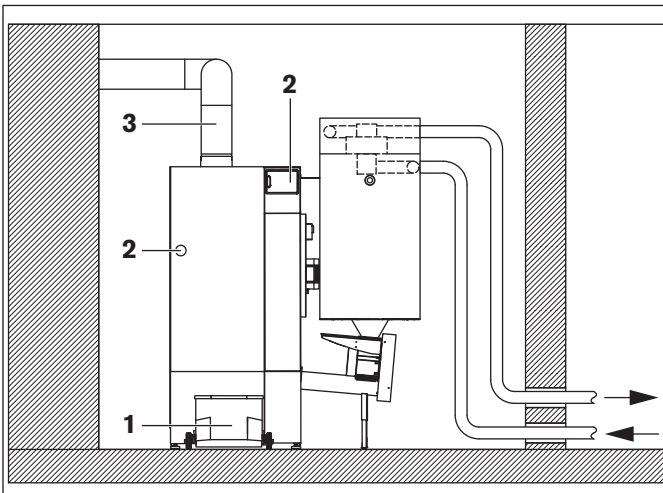

Item	Maintenance tasks	Frequency
1	Clean and empty ash box (optionally ash transportation system)	as required
2	Check safety devices	Once a month (waived if a maintenance contract has been signed)
3	Check and clean flue pipe (more often at excessive contamination)	1x monthly

## 3 Annual cleaning

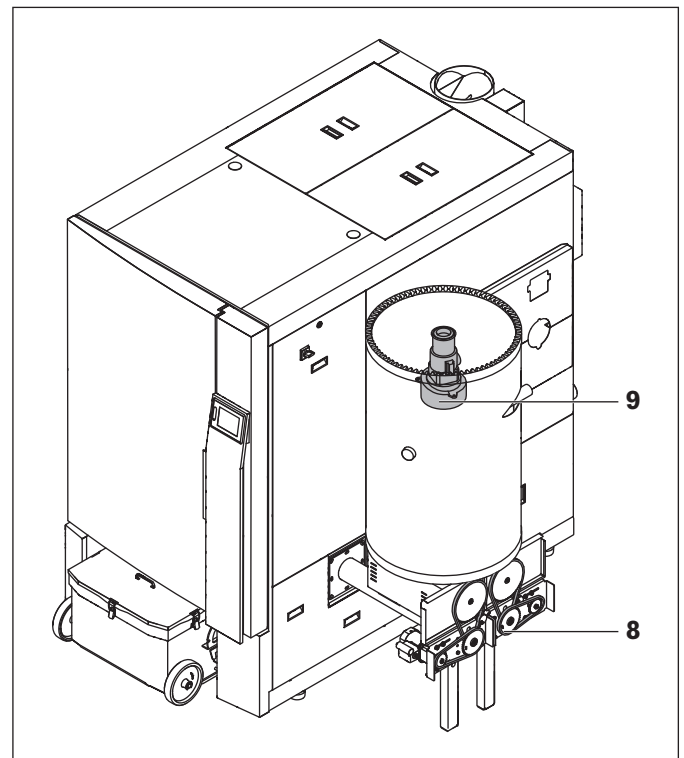
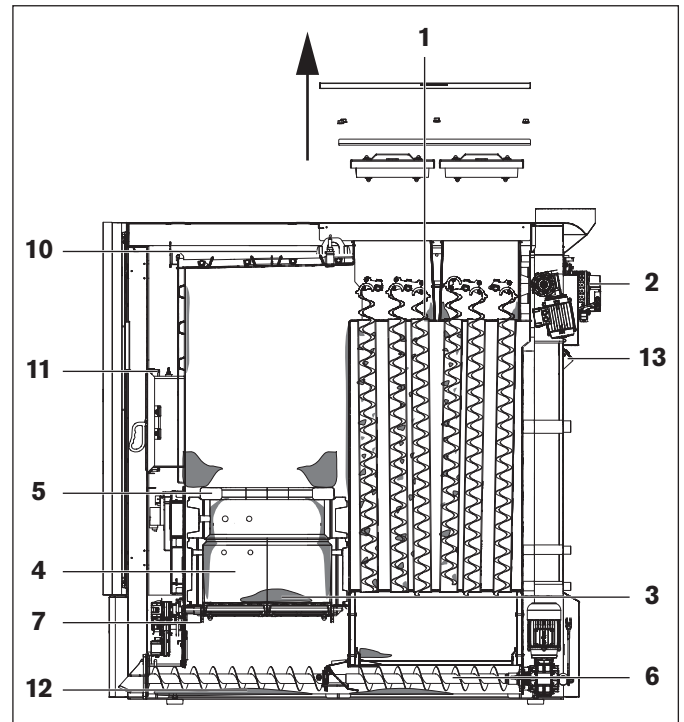

Item	Cleaning work
1	Pull out turbulators, tap off and clean the turbulator space
2	Vacuum exhaust fan and flue pipe
3	Clean rust holes
4	Clean combustion chamber with ash cleaner
5	Remove and clean flame concentration plate
6	Remove maintenance opening and clean fly ash space

Item	Cleaning work
7	Clean ignition
8	Grease stoker chain and check chain tension
9	Clean the pellet vacuum turbine and filter
10	Clean lambda sensor and combustion chamber sensor
11	Check sealings
12	Remove ash under the grate (especially from by the ash grate)
13	Clean recirculation with vacuum cleaner
14	Check safety installations (main power switch, safety valve)

Frequency: at least once annually and no later than after 4000 full-load hrs, 8000 partial-load hrs or after a message has appeared on the control unit.

→ Boiler monitoring and cleaning intervals are based on the operation hours and fuel quality. Observe state regulations and the inspection and sweeping intervals dictated by these.

### 3.1 Preparation for cleaning

- Switch off system at the control unit (BCE) (**Off** operating mode)
- Let system cool down
- Disconnect the system from the power supply (**Off** main switch)

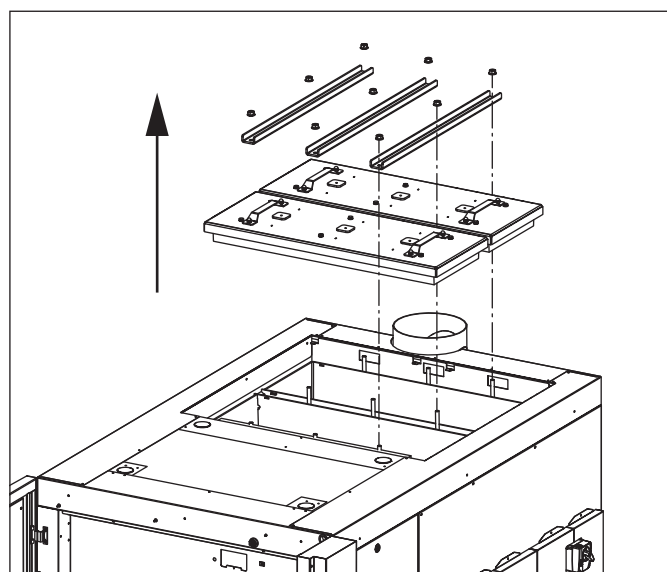
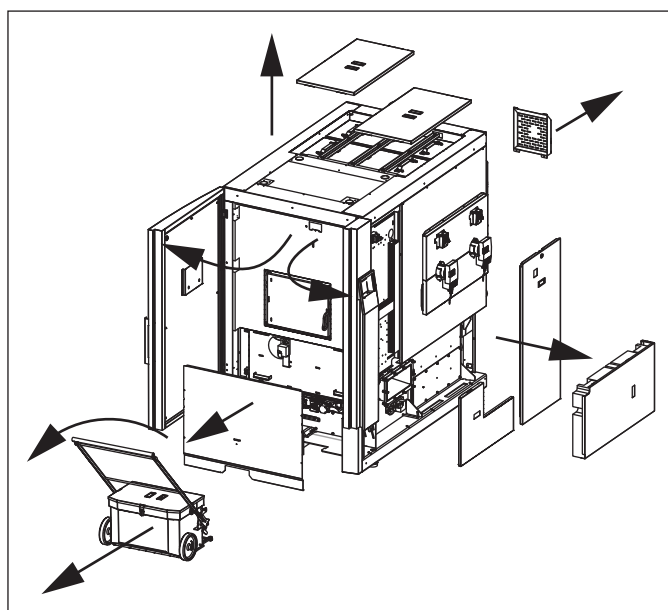

- Remove casing top and maintenance cover
- Dismantle the retention plates
- Subsequently remove the maintenance lids
  - Clean maintenance lid over the heat exchanger
- Remove the cover from the cleaning motor at the back of the system
- Open cover doors and remove ash box
- Dismount lower front wall
  - Remove 4 screws
  - Disconnect ash box switch
  - Pull cover forwards
- Remove the cover of the control box
- Remove lower side covers
  - Loosen screw at the back cover of the fly ash space
  - Pull cover backwards and remove
  - Remove insulation
  - Lift cover from the stoker and remove

### 3.2 Cleaning the turbulators and the turbulator chamber

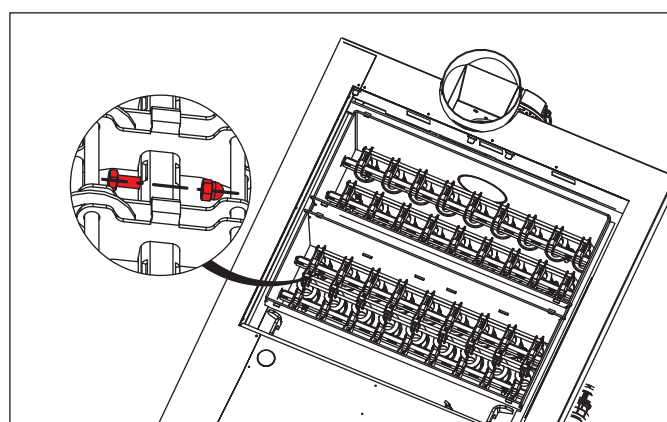

- Loosen the turbulators' fixing points
- Tap turbulators and remove upwards

### 3.3 Cleaning the exhaust fan and the flue pipe

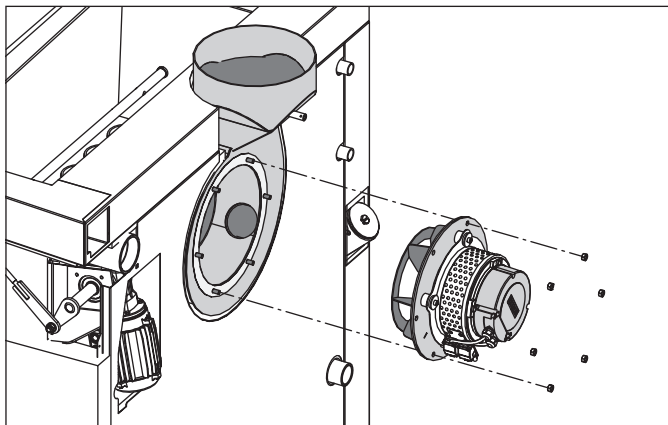

- Disconnect electrical connection from the motor
- Loosen copper nuts and remove exhaust fan backwards
  - The ring sealing on the exhaust fan housing protects the exhaust fan seal from sticking to the housing
  - If the exhaust fan sealing gets stuck, replace both it and the ring sealing
- Clean dirt from the flue pipe, housing and impeller
  - Don't damage the impeller (don't use compressed air)
- Clean recirculation junction of the housing with a vacuum cleaner

### 3.4 Cleaning the lambda sensor and the combustion chamber sensor

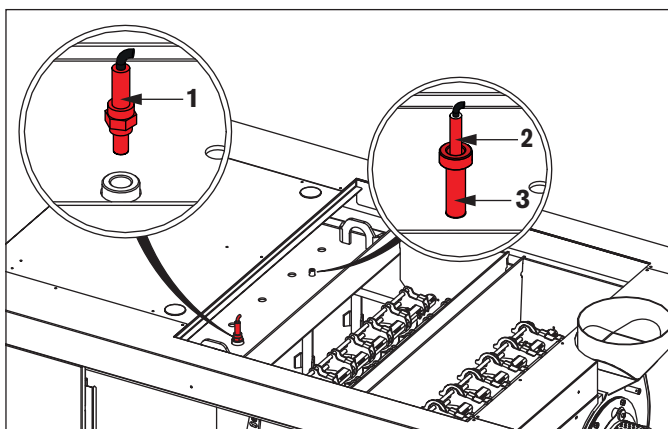

- Disconnect and unscrew the lambda sensor (1)
- Place sensor head down
- Remove dirt with a soft cloth
  - Debris falls down

#### **i** NOTE

Do not tap the lambda sensor.  
 Do not blow off with compressed air.  
 Do not touch the sensor with sharp items and do not use any chemicals for cleaning (brake cleaning fluid, etc.).

- Pull out the combustion chamber sensor (2) and the ceramic protective pipe (3) if present and wipe them with a soft cloth

### 3.5 Cleaning the combustion chamber and post combustion chamber

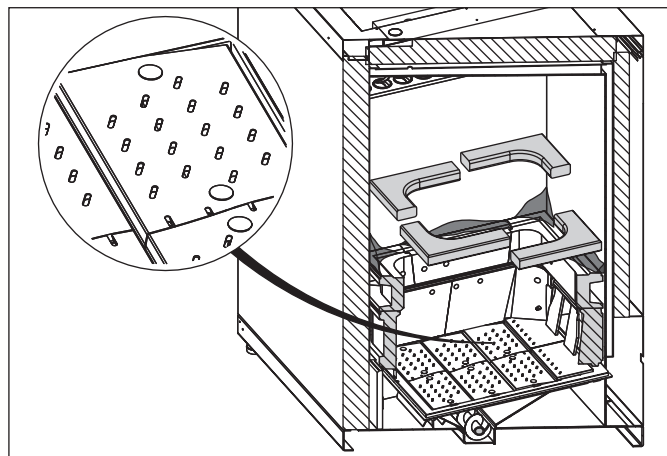

- Open combustion chamber door
- Remove the split flame concentration plate from the combustion chamber
  - Clean flame concentration plate in the combustion chamber
- Clean the combustion chamber and post combustion chamber with a cleaning poker
- Clean the rotating grates and ensure the holes are free of any dirt

### 3.6 Cleaning the ignitions

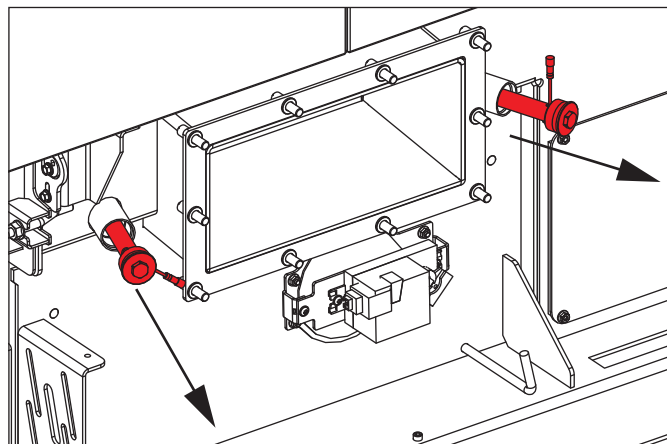

- Loosen electric connection to the ignition
- Unscrew the ignition
- Clean ignition and ignition sleeve (on the boiler) using a vacuum cleaner
  - Mount ignition hand-tight only

### 3.7 Cleaning the ash chamber

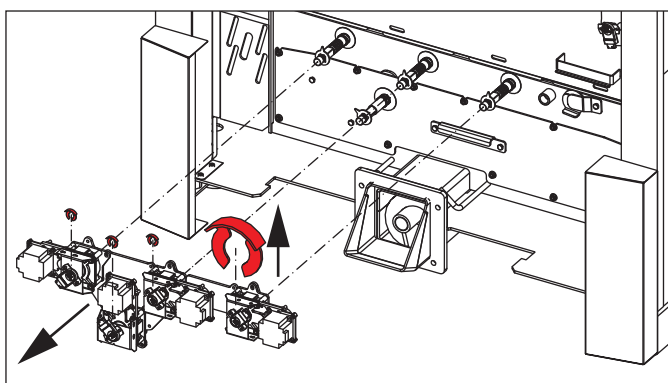

- Remove grate motors and torque-support plates
- Pull off the safety clamp of each motor shaft
- Pull support plate with all motors forwards

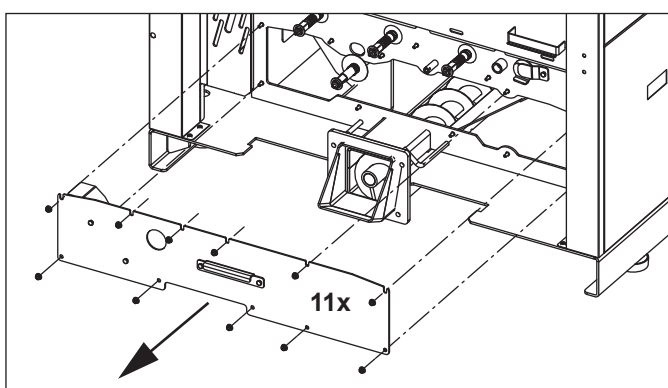

- Loosen the maintenance lid's fastenings and remove it

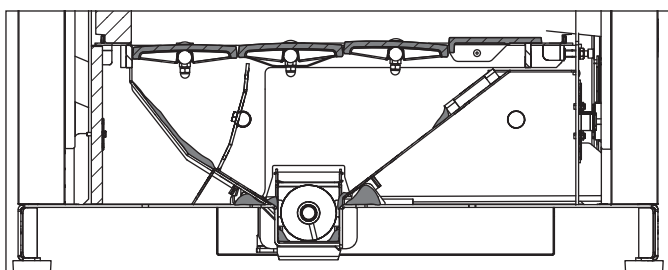

- Remove any accumulated ash and debris from the ash chamber  
→ Especially under the ash grate and the intermediate grate (flap)

### 3.8 Cleaning the fly ash area

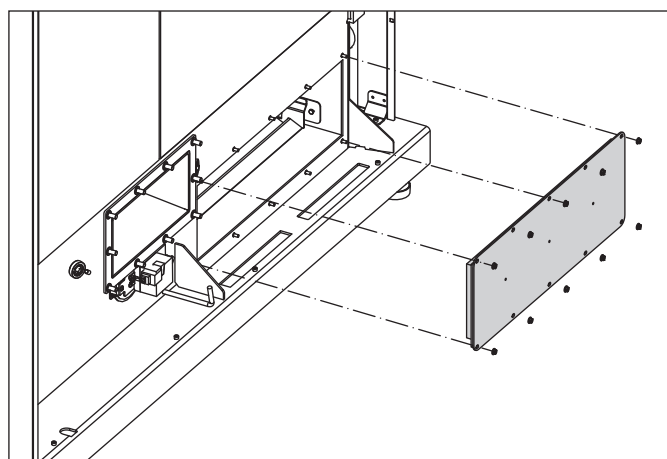

- Loosen the fastenings of the fly ash chamber's cover and remove it

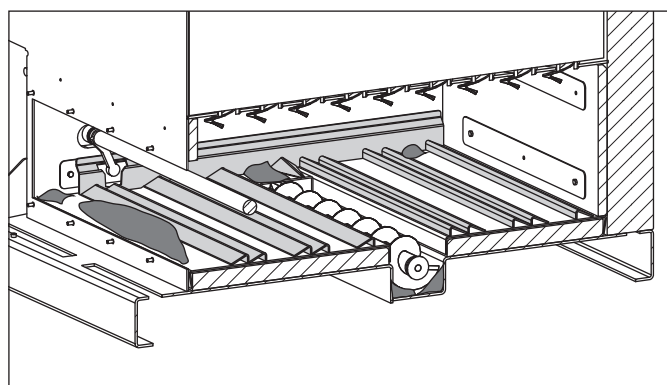

- Remove any ash and debris from the fly ash area

### 3.9 Cleaning the recirculation

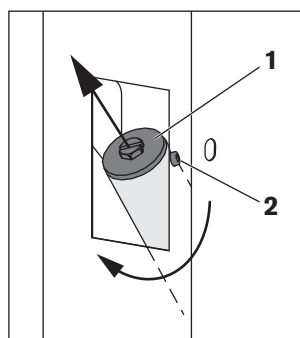

- Mark recirculation settings
- Turn the recirculation slider (1) until the screw can be loosened
- Take the screw (2) out completely
- Pull the recirculation slider (1) out of the tube
- Clean slider of recirculation and tube with vacuum cleaner

### 3.10 Cleaning the pellet vacuum turbine

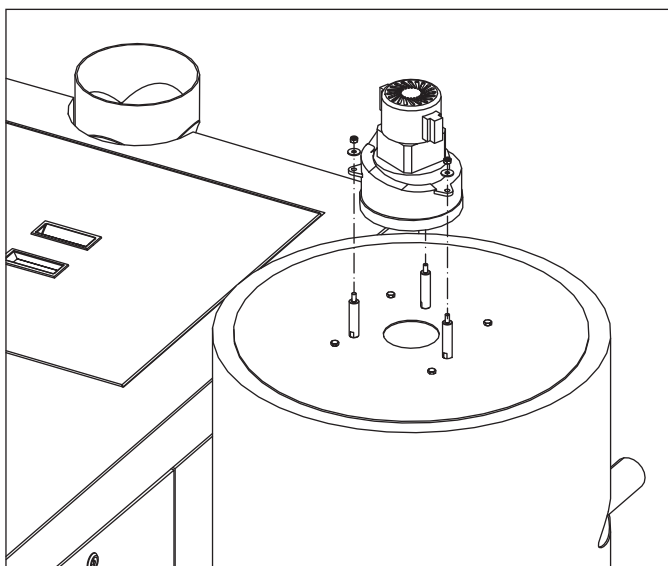

- Remove the day hopper's casing cover
- Remove the insulation at the top
- Disconnect plug of vacuum turbine
- Loosen the clamp of the return air hose and remove the hose from the vacuum turbine
- Loosen tension ring from day hopper
- Remove lid and vacuum turbine upwards
- Loosen the vacuum turbine's fixation points and remove them from the cover
- Remove dust from sieve, vacuum turbine and return air hose
- Re-assemble system after cleaning

### 3.11 Emptying the ash box

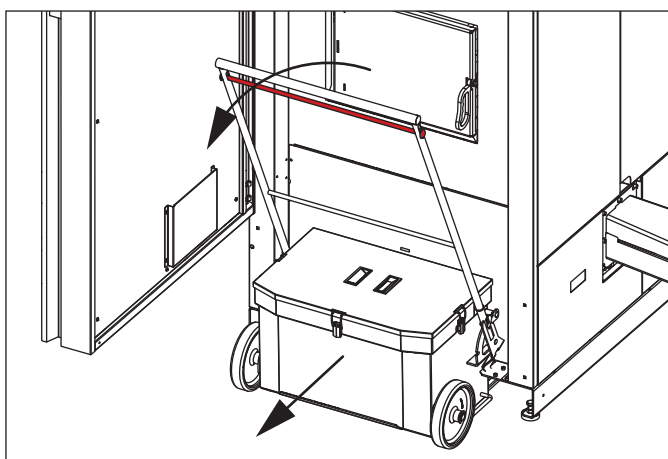

- Open the cover door
- Pull the ash box's release lever upwards
- Pull the handle backwards until it clicks into the transport position
  - Now the ash box can easily be transported to the emptying point
- Place the transport handle in the emptying position
- Open the cover's fasteners and remove the cover
- Empty the ash box
- Put the cover back on and secure it with the fasteners
- Put the handle back into the transport position

- Reattach the ash box to the system
  - It is locked on both sides by folding up the transport handle

## 4 Disposal information

### 4.1 Disposal of created ash

- Ash must be disposed of according to your national waste management regulations
  - If natural wood is used as a fuel, then the ash can be regarded as a high-quality mineral fertilizer and can be used for composting
  - Caution: watch out for ember pockets

### 4.2 Disposal of wear and spare parts

- Wear and spare parts must be disposed of according to your national waste management regulations
  - Only use equivalent spare parts approved by Hargassner Ges mbH

### 4.3 Disposal of system components

- Ensure environmentally compatible disposal in accordance with national regulations
- Recyclable materials must be cleaned and sorted before being passed on for recycling
  - System (boiler)
  - Fuel extraction
  - Insulation material
  - Electrical and electronic parts
  - Plastics

## Chapter V: Troubleshooting

### CAUTION

#### Material damage

#### Damage to the system due to defective parts or incorrect operating states

- Contact Hargassner Ges mbH or the commissioning engineer in case of higher power consumption, higher temperatures or vibrations of motors, unusual noises or smells, release of safety devices, etc.
- Perform mandatory maintenance tasks regularly.

## 1 Information and error display

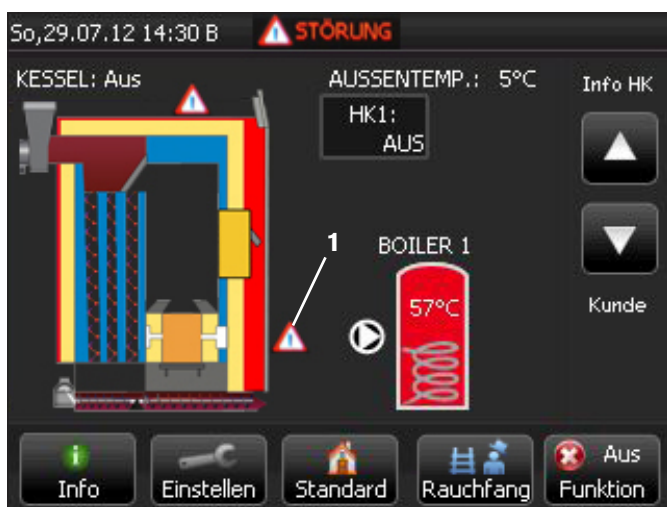

Information and error messages are displayed on the control unit.  
 → A warning triangle appears on the standard menu at the position where the error has occurred (1)  
 → Yellow triangle = information  
 → Red warning triangle = error

The following instructions for rectifying errors are intended for the system operator.

If it is not possible to rectify the error through the operator, the commissioning engineer / Hargassner must be informed.

## 2 Viewing the error list

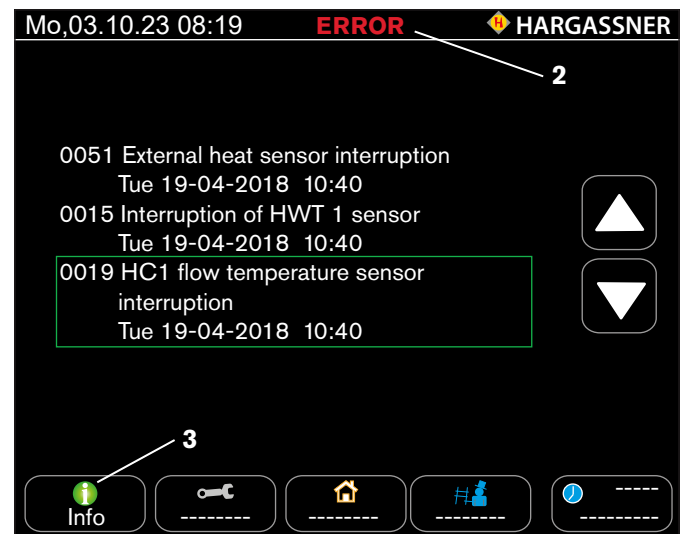

- If error messages occur, press Error (2)  
 → Displays the error list (current errors)

## 3 Acknowledging and rectifying an error

- Press the Info (3) button
- Follow the instructions to rectify the error
- After rectifying the error, press the button

## 4 BCE failure

### DANGER

#### Danger to life

#### Electric shock from contact with live terminals

- Observe information signs.
- Before starting work, check that no voltage is present using a voltmeter.

A BCE failure can occur due to a defective fuse, missing power supply or missing connection to the main board.

- Check the voltage supply and fuse  
 → Fuse F13 on the main board  
 → Mains supply of terminal L / PE / N
  - Check LED H7 on the main board  
 → Check CAN bus cable  
 → Replace BCE or cable
- ⇒ See [Electrical manual](#)

## 5 Temporary emergency operation (restart without HW test)

If an error is clearly a result of a defective boiler board and the connected component works correctly, the control unit may be run in temporary emergency operation (until the service department arrives) without a hardware test of the component in question.

- Ignore the hardware test as soon as the error message appears  
or
- Switch to Manual operating mode on the control unit
- Switch to the respective manual parameter
- Confirm **Without HW test**

The boiler runs at a maximum of 60% output.



## Supplement

### Note

Please be advised that we do not accept responsibility for damage or malfunctions resulting from non-observance of the manual

### Copyright notice

This manual must be kept confidential. The manual is intended solely to be used by authorised persons. Transfer to third parties is prohibited and is liable to compensation. All rights reserved, including for translations. No part of this manual may be reproduced or processed, duplicated or distributed using electronic systems without the permission of Hargassner Ges mbH.

### Special measures prior to commissioning by the operator

Observe your local official regulations for system operation and accident prevention. Work on hydraulic systems must be carried out only by personnel with specialised knowledge and experience in heating engineering and pipework construction.

### Liability

The product is a state-of-the-art product, manufactured and tested according to recognised safety regulations, and therefore reliable and safe to operate. However, improper use may cause lethal hazards for the operator or third parties or may damage the system and other property.

Ensure that the product is used in accordance with its intended purpose and in a safety-conscious and hazard-conscious manner, and that it is in perfect technical condition. Particularly errors tending to affect the safety shall be resolved immediately.

Liability for the product functioning correctly will always be borne by the owner or operator if the device has been improperly maintained or repaired by individuals who have not been authorised by Hargassner Ges mbH or has been handled or operated in a manner that does not comply with the device's intended use. In the interest of the continuous development and improvement of our products, we reserve all rights to make technical changes to the information contained in our printed material. Changes, errors and printer's errors do not justify claims for damages. Only original Hargassner spare parts and accessories must be used.

In addition to the guidelines in this operation manual, please follow general guidelines for safety and accident prevention. Hargassner Ges mbH is not liable for any damage resulting from failure to observe the instructions and guidelines in this manual. This system's reliability is guaranteed by Hargassner Ges mbH's vast experience, very modern production methods and extremely high quality standards. Hargassner Ges mbH cannot be held

liable for safe operation of the product if it has been handled or operated in a manner that does not comply with its intended use.

### Warranty claims

The customer has NO warranty claims:

- if fuel is missing, wrong or of poor quality
- if a non-licensed commissioning engineer or plumber installs the product
- if damages occur through incorrect assembly, commissioning, misuse or lack of maintenance
- if the installation manual and operation manual are not followed
- for damages that do not affect the performance of the system, such as paint defects, ...
- for damages arising from force majeure like fire, flooding, lightning stroke, electrical surge, power loss, ...
- for damage caused by air pollution, heavy dust, aggressive vapours, oxygen corrosion (non diffusion-tight plastic tubing), installation in inappropriate rooms (laundry room, hobby room, etc.) or continued use despite the occurrence of a defect

To ensure repair or maintenance work relating to defects and malfunctions not mentioned in this manual is carried out properly, always contact **Hargassner Ges mbH** beforehand. The warranty and liability terms in **Hargassner Ges mbH's** general terms and conditions will not be extended because of information in this manual. The **safety instructions** in this manual must be observed. Only use Hargassner spare parts or equivalent spare parts that have been approved by **Hargassner Ges mbH**. Constant technical innovations mean that we reserve the right to modify the design of our products and services without notice. For all queries, please be sure to quote the **serial number** of the product.

We wish you every success with the Hargassner product.



# Declaration of Conformity

Hargassner Ges mbH  
Anton Hargassner Strasse 1  
4952 Weng im Innkreis  
AUSTRIA

The manufacturer is also the party authorised to compile the technical documentation.

Type of product: Boiler for solid fuels with automatic loading

Type: Pellet systems  
Eco-PK 250-330  
optional with de-ash system AAS, AFS, MAFS  
optional with fuel extraction RAS 150-800, RAPS, PWB, AUP  
optional with particle separator Multicyclone & eCleaner 130-230

Standard: from 10.10.2022

The versions of the stated products launched onto the market by us comply with the regulations laid down in the following European directives:

Machinery Directive 2006/42/EC  
Low Voltage Directive 2014/35/EU  
EMC Directive 2014/30/EU  
Ecodesign directive 2009/125/EG  
Ecodesign directive (EU) 2015/1189

Conformity with the directives is verified by the manufacturer's compliance with the relevant requirements of the following standards:

EN 303-5:2012 Heating boilers for solid fuels, manually and automatically stoked, nominal heat output of up to 500 kW  
EN ISO 12100:2010 Safety of machinery - General principles for design - Risk assessment and risk reduction  
ÖNORM EN 60335-2-102:2016 Household and similar electrical appliances - Safety - Particular requirements for gas, oil and solid-fuel burning appliances having electrical connections  
OVE EN 60730-1:2017 Automatic electrical controls - Part 1: General requirements

The manufacturer hereby declares that the standard versions of the systems mentioned above comply with the stated regulations.

Place, date: Weng, 03.10.2022

Company: Hargassner Ges mbH

Name: Dr. Johann Gruber

Signature: 

Function: Head of Development

notes



notes

notes

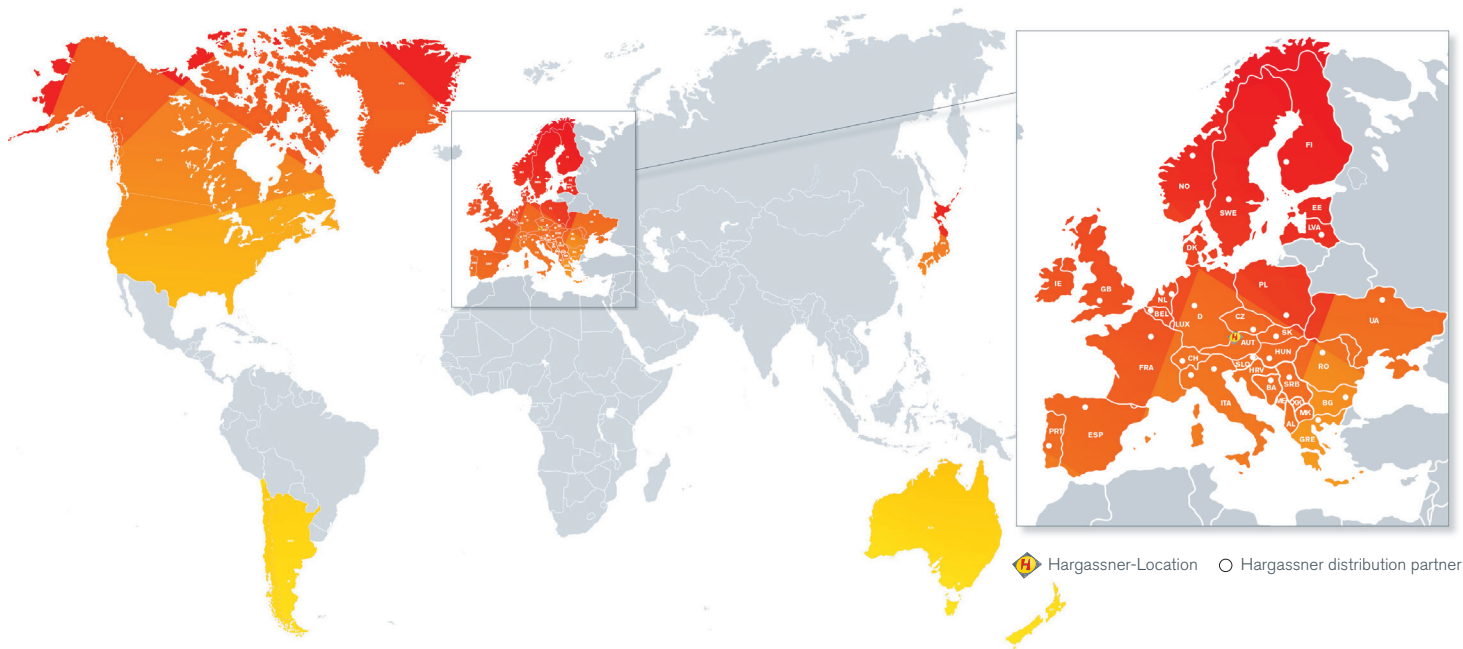

## Your expert for **SUSTAINABLE HEATING**

Complete Hargassner range: pellet boilers, wood chip boilers, wood log boilers, accumulator tanks, industrial boilers up to 2.5 MW, heating modules, filling augers, Power-Box warm-air module, heat pumps, solar panels and hydraulic accessories

**HARGASSNER Ges mbH**  
Anton Hargassner Straße 1  
4952 Weng im Innkreis  
AUSTRIA  
+43 77 23 52 74 - 0  
office@hargassner.at

[hargassner.com](http://hargassner.com)