

# Installation manual Pellet Boiler Eco-PK 130-230

**HARGASSNER**  
HEIZTECHNIK DER ZUKUNFT



**Follow and store this manual**

## **HARGASSNER Ges mbH**

A 4952 Weng, Upper Austria  
Tel.: +43/7723/5274-0  
Fax: +43/7723/5274-5  
office@hargassner.at  
www.hargassner.com

EN - V04 02/2022 - 11059620

# Contents

---

<b>1 General</b> .....	<b>4</b>
<b>2 Transport</b> .....	<b>5</b>
2.1 Transport weight .....	5
2.2 Place of installation .....	5
2.3 Space requirements of the system, operating area .....	5
<b>3 Installation dimensions</b> .....	<b>6</b>
3.1 Space requirements .....	6
3.2 Dimensioning .....	7
3.3 Connections .....	8
3.4 Technical data of Eco-PK 130-170 .....	9
3.5 Technical data of Eco-PK 200-230 .....	10
<b>4 Scope of delivery overview</b> .....	<b>11</b>
<b>5 Unloading the system</b> .....	<b>12</b>
<b>6 Setup</b> .....	<b>13</b>
6.1 Removing the cover door .....	14
<b>7 Installing the trim panel</b> .....	<b>15</b>
<b>8 Installing the exhaust fan motor</b> .....	<b>15</b>
<b>9 Fitting the leveling feet</b> .....	<b>15</b>
<b>10 Installing the stoker unit</b> .....	<b>16</b>
10.1 Installing the pellet day hopper .....	17
<b>11 Mounting instructions for pellet hoses and pellet steel pipes</b> .	<b>18</b>
11.1 Earthing the pellet hoses and pellet steel pipes .....	18
11.2 Marking the pellet hoses .....	19
11.3 Laying pellet hoses .....	21
11.4 Laying pellet steel pipes .....	23
11.5 Accessories for pellet hoses and pellet steel pipes .....	25
<b>12 Ash box</b> .....	<b>27</b>
12.1 Installing the ash box flange .....	27
12.2 Ash box (75L) installation .....	28
<b>13 Design of the fuel storage room</b> .....	<b>31</b>
13.1 Ventilation of the fuel storage room .....	31
13.2 Safety in the fuel storage room .....	32
<b>14 Facilities on site</b> .....	<b>33</b>
14.1 Country-specific regulations .....	33
14.2 Qualification of installation staff .....	33
14.3 Fire extinguisher .....	33
14.4 Designs of the boiler room .....	34
14.5 Ventilation of the boiler room .....	35
14.6 Flue connection, flue pipe .....	35
14.7 Flue draught stabilizer .....	36

<b>15 Hydraulic installations</b> .....	<b>36</b>
15.1 Back-end protection unit .....	37
15.2 Domestic hot water mixer .....	38
15.3 Safety valve .....	38
<b>16 Electrical installations</b> .....	<b>39</b>
16.1 Installing the main power switch .....	40
16.2 Cable installation .....	40
<b>17 Sensor installation</b> .....	<b>41</b>
17.1 Outdoor sensor .....	41
17.2 Flow, accumulator and external heat sensors .....	41
<b>18 Remote control FR25 / FR35 / FR40</b> .....	<b>43</b>
18.1 FR25 remote control (analogue) .....	43
18.2 FR35 remote control (digital) .....	43
18.3 FR40 remote control (digital) .....	43
<b>19 Extension module, board or controller</b> .....	<b>44</b>
19.1 Heat circuit modules 0, 1, 2 .....	44
19.2 Additional board I/O 36 (HC AB/F, 5-sensor accumulator or differential controller) .....	44
19.3 Heat circuit controller HKR .....	44
<b>20 Permits and reporting requirements</b> .....	<b>44</b>
<b>21 Commissioning the system</b> .....	<b>44</b>

# 1 General

This installation manual is part of the system's operating manual.



## DANGER

### Danger to life

**Non-observance of the safety instructions may lead to death, injuries and damage**

- Observe the safety instructions attached to the system and in the manual.
- The activities described may only be carried out by assembly personnel trained by Hargassner.



## DANGER

### Danger to life

**Risk of death, injuries and damage due to incorrect design of the boiler room and fuel storage room**

#### Installation space

- Execution according to the local fire protection regulations.
- Ensure fire-safe, level and firm floor condition.
- Ensure there is a sufficient supply of combustion air that meets local regulations.
- Ensure weatherproof and frost-proof design.
- Observe the load-bearing capacity of the foundations. Weight of the system.

#### Fuel storage room

- Observe static requirements. Weight of the quantity of fuel stored.
- Ensure weatherproof and frost-proof design.
- Ensure dust-tightness.
- Ensure easy access and easy refill of the fuel storage room.
- Install safety devices in accordance with local regulations.
- Attach safety instructions near the access.

## 2 Transport

### 2.1 Transport weight

The system is delivered on pallets in individually packaged units.

Description	Eco-PK 130-170	Eco-PK 200-230
Pallet with boiler depending on version	Approx. 1300 kg	Approx. 1400 kg
Pallet with stoker unit and day hopper	max. 300 kg	

#### Unloading, inspection and damage report

- Unload system
- Remove packaging
- Dispose of packaging in accordance with the Waste Disposal Act
  - ☞ Recycling materials can be recycled in a separated and cleaned state
- Check the system for transport damage
- Check that the delivery is complete
  - ⇒ "Scope of delivery overview", p. 11
  - ☞ Record any incompleteness of the delivery immediately in writing and send a report to Hargassner Ges mbH
  - ☞ Record any transport damage immediately in writing, take photographs and send a report to Hargassner Ges mbH
  - ☞ If the transport company is at fault, the complaint must also be noted on the shipping documents

### 2.2 Place of installation

#### Conditions

- Sufficient light
- Ensure fireproof, level and solid floor and ceiling construction
- Free of disturbing electrical installations and pipes

### 2.3 Space requirements of the system, operating area

- See data sheet or individual customer drawing
- Observe minimum distances and space requirements
- Drawing of the installation dimensions
- Leave a gap of 600 mm for access to the chimney

Description	Eco-PK 130-170	Eco-PK 200-230
Room height	min. 220 cm	min. 240 cm

### 3 Installation dimensions

#### 3.1 Space requirements

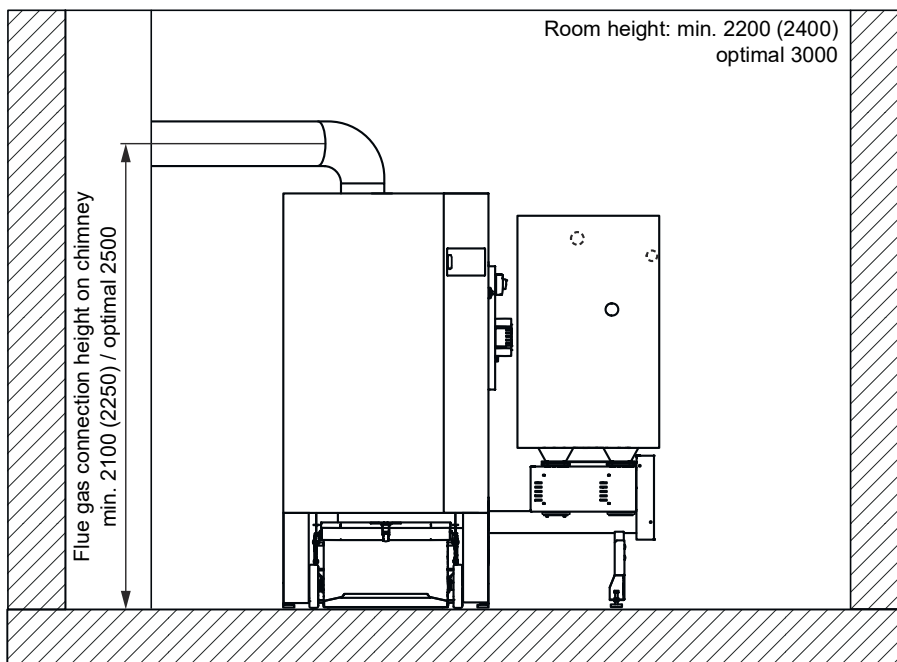
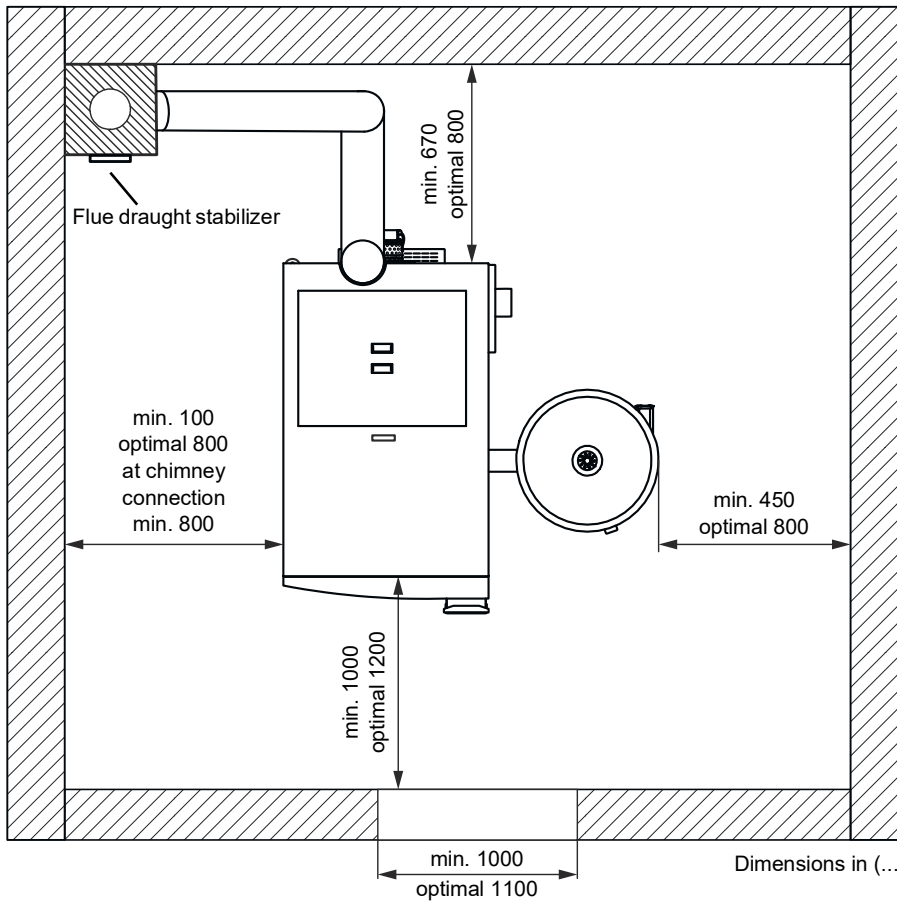

## 3.2 Dimensioning

Dimensions in (...) valid for Eco-PK 200-230  
all dimensions in mm

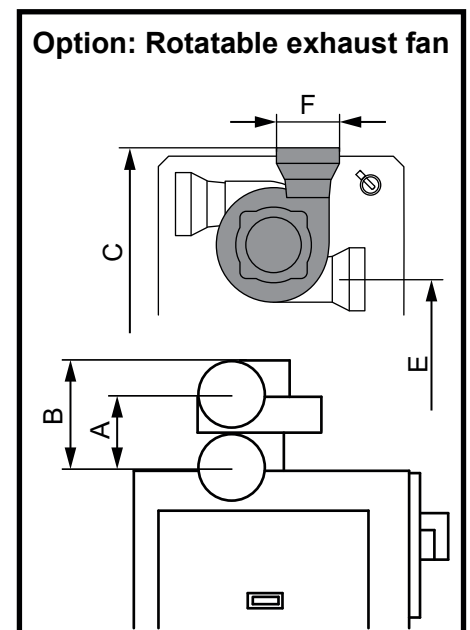
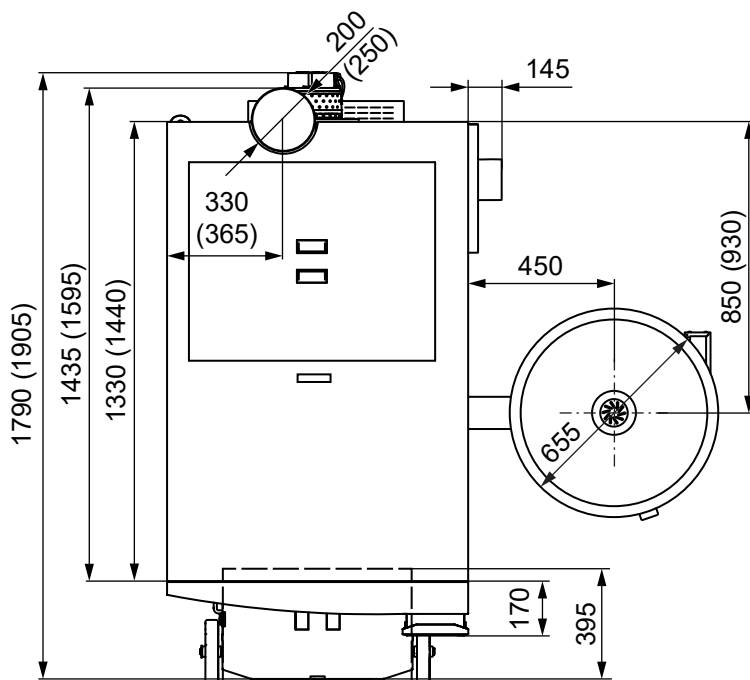
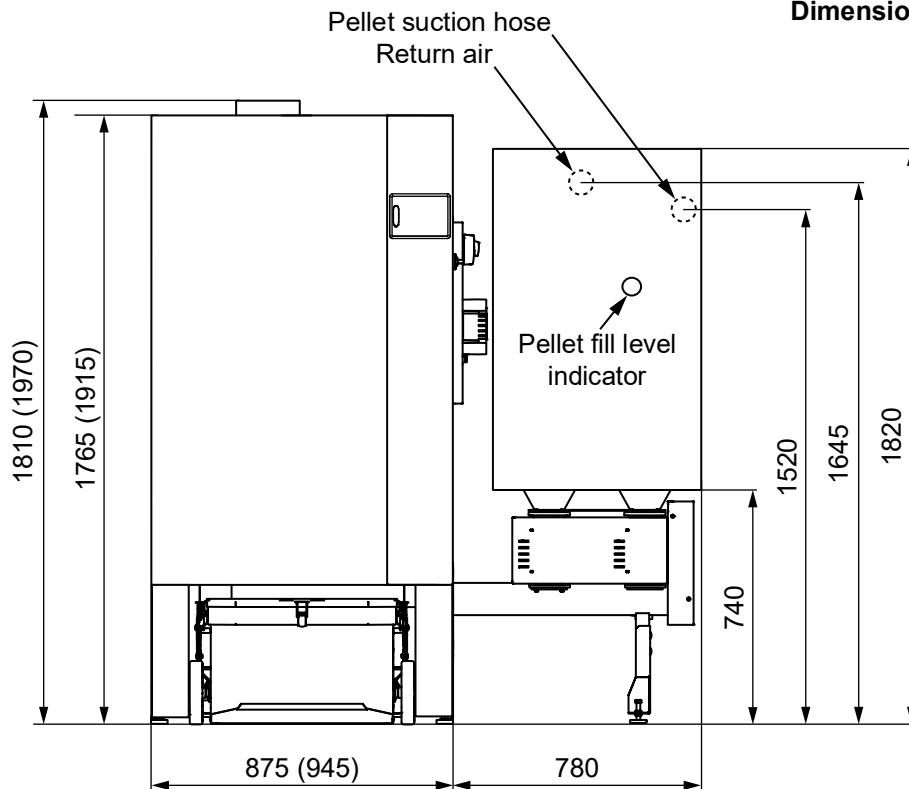

	A	B	C	E	F
Eco-PK 130-170	225	325	1790	1360	Ø200
Eco-PK 200-230	300	425	1950	1510	Ø250

### 3.3 Connections

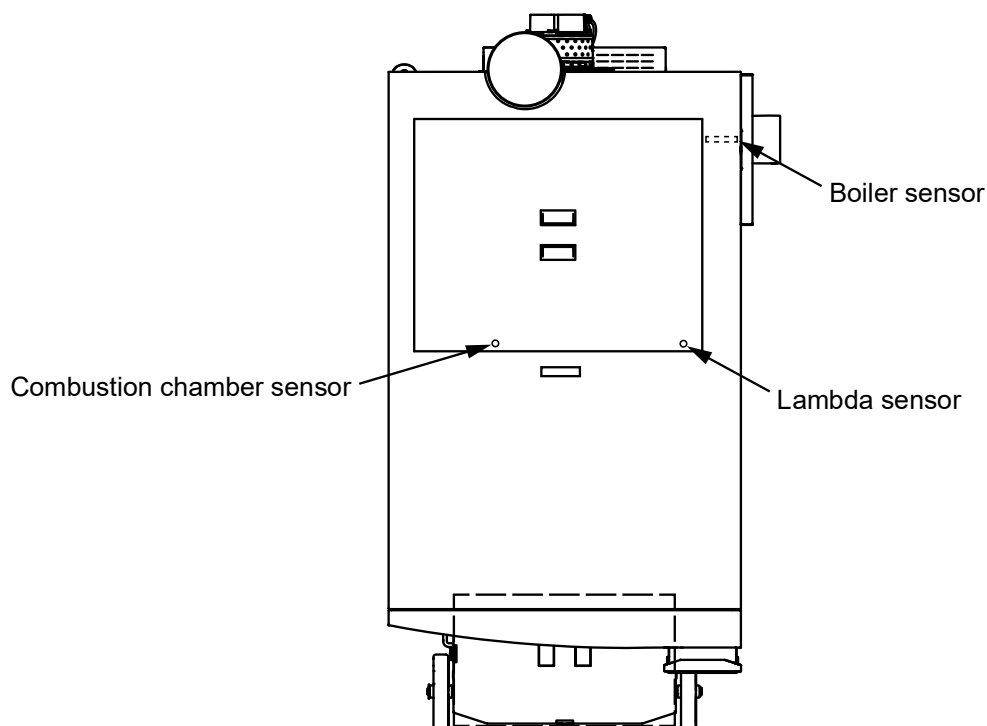
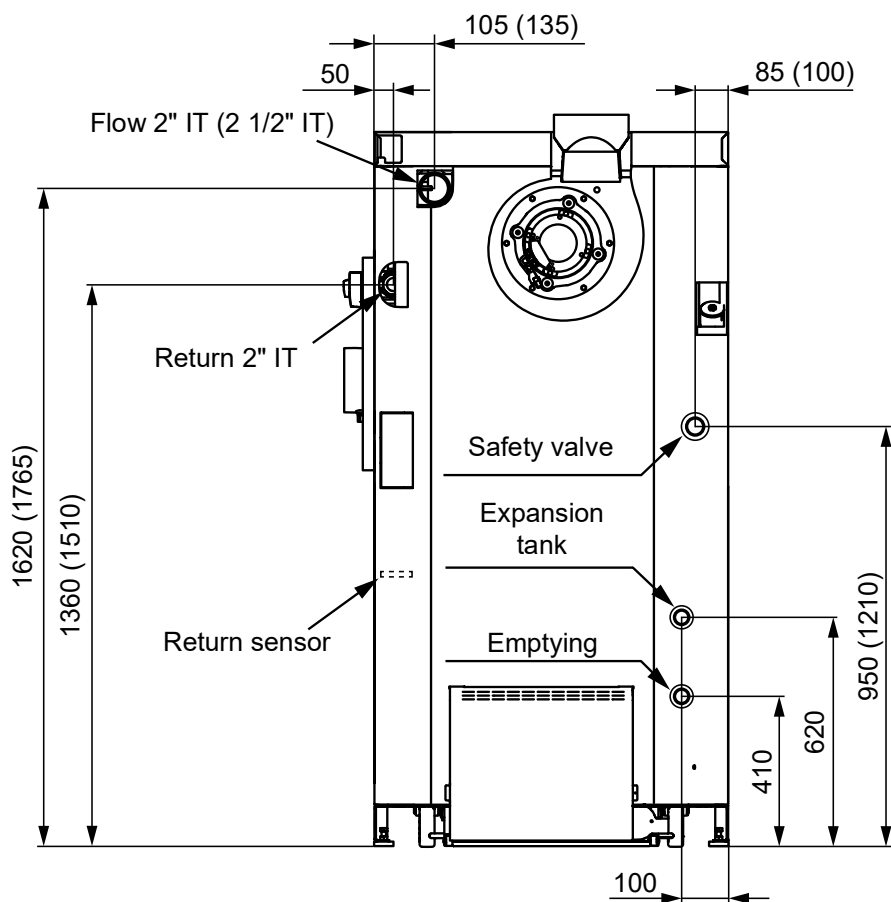

### 3.4 Technical data of Eco-PK 130-170

Designation	Unit	Eco-PK 130	Eco-PK 150	Eco-PK 170
Nominal heating output	kW	39 - 130	44.7 - 149	49 - 166
Fuel heat output	kW	139	158.8	176.2
Boiler class (according to ÖNORM EN 303-5:2012)		5		
Fuel and fuel class (according to EN ISO 17225)		Wood pellets (A1)		
Boiler height	mm	1810		
Boiler width	mm	875		
Boiler depth	mm	1790		
Transport dimensions (HxWxD)	mm	1810 / 875 / 1435		
FL connection height	mm	1620		
RT connection height	mm	1360		
Emptying	inches	3/4 IT		
Flow	inches	2 IT		
Return	inches	2 IT		
Expansion tank connection	inches	3/4 IT		
Safety valve connection	inches	1 IT		
Permissible operating pressure	bar	3		
max. operating temperature	°C	95		
Water content	Liters	253		
Weight	kg	1190		
Req. delivery pressure	Pa	5		
Flue draught max. limit	Pa	10		
Flue pipe diameter	mm	200		
Flue gas temperature	°C	150		
CO <sub>2</sub>	%	14		
Mass flow rate	kg/sec	0.0731	0.0836	0.0926
Water resistance dT 10°	mbar	160.0	184.6	209.21
Water resistance dT 20°	mbar	42.7	49.0	55.5
Power consumption	W	191	201	211
Electric supply		400V AC, 50 Hz, 13 A		
Noise emissions (normal operation) <sup>a</sup>	dBA	57		

a. Emission of airborne noise from the pellet boiler in the boiler room; no significance attached to acoustic emissions at the chimney mouth or in the surrounding area

### 3.5 Technical data of Eco-PK 200-230

Designation	Unit	Eco-PK 200	Eco-PK 220	Eco-PK 230
Nominal heating output	kW	59 - 199	59 - 216	67.8 - 226
Fuel heat output	kW	210.1	228.1	238.6
Boiler class (according to ÖNORM EN 303-5:2012)		5		
Fuel and fuel class (according to EN ISO 17225)		Wood pellets (A1)		
Boiler height	mm	1970		
Boiler width	mm	945		
Boiler depth	mm	1905		
Transport dimensions (HxWxD)	mm	1970 / 945 / 1595		
FL connection height	mm	1765		
RT connection height	mm	1510		
Emptying	inches	3/4 IT		
Flow	inches	2 1/2 IT		
Return	inches	2 IT		
Expansion tank connection	inches	3/4 IT		
Safety valve connection	inches	1 IT		
Permissible operating pressure	bar	3		
max. operating temperature	°C	95		
Water content	Liters	360		
Weight	kg	1320		
Necessary conveying requirements	Pa	5		
Flue draught max. limit	Pa	10		
Flue pipe diameter	mm	250		
Flue gas temperature	°C	160		
CO <sub>2</sub>	%	14		
Mass flow rate	kg/sec	0.1105	0.1200	0.1255
Water resistance dT 10°	mbar	227	250	263
Water resistance dT 20°	mbar	63	69	72
Power consumption	W	226	226	228
Electric supply		400V AC, 50 Hz, 13 A		
Noise emissions (normal operation) <sup>a</sup>	dBA	56		

a. Emission of airborne noise from the pellet boiler in the boiler room; no significance attached to acoustic emissions at the chimney mouth or in the surrounding area

## 4 Scope of delivery overview

The add-on parts are packaged individually and can be found in the boiler or on the pallets.

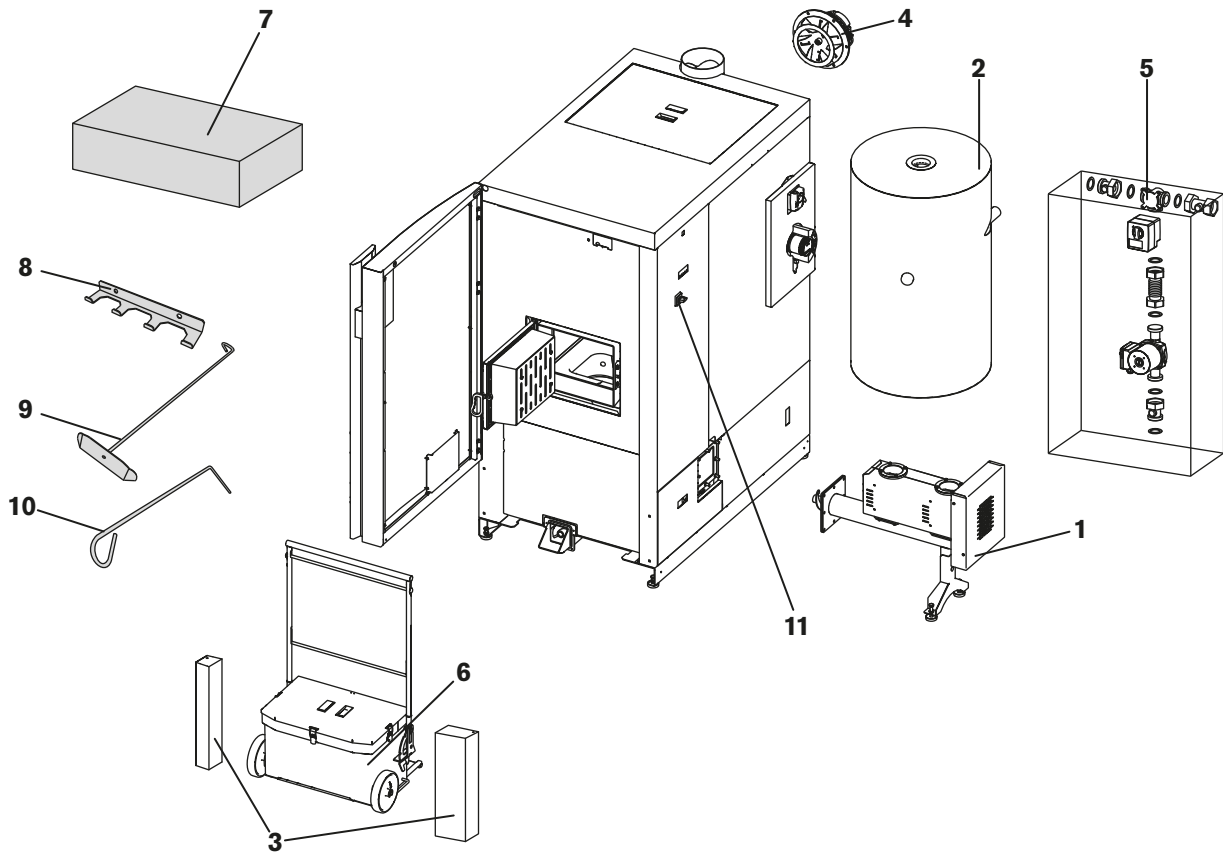

Pos	Description	Function
1	Stoker unit	Carries the fuel into the combustion chamber
2	Day hopper	Carries the fuel from the storage room to the stoker unit
3	Trim panel	Lower part of the cover door
4	Exhaust fan motor	Transports the flue gas from the boiler unit into the chimney
5	Back-end protection unit (optional)	Adjusts to a constant return temperature
6	Ash box	For collecting the ash from the combustion process
7	Sensor package	Flow sensor, return sensor, safety temperature breaker (STL), thermostat, flue gas sensor, lambda sensor, etc., according to sensor plan
8	Flue tool set holder	Wall holder for the flue tool set
9	Ash slider	For cleaning the system
10	Poker	For cleaning the combustion chamber
11	Main power switch	On/Off switch for providing power to the boiler

## 5 Unloading the system

### DANGER



#### Danger to life and risk of material damage

##### Risk of death, injuries, damage due to falling or toppling loads

- The system may only be set up by qualified and trained staff.
- Only use tested lifting gear that has a sufficient load-bearing capacity and is in perfect condition.
- Do not exceed the maximum permissible load (load-bearing capacity) of the crane, forklift or lift truck. See the type plate.
- Never use bearing bolts, spindles, shaft ends or moving parts as attachment points to hoist the system or system parts.
- Make sure that nobody stands under suspended loads.
- First lift the system only minimally from the ground. Only after the load has been completely picked up can the system be transported over longer distances.
- Check that the load attachment points are chosen correctly and are secure. Secure against tipping.
- Suspend the machine centrally to prevent the machine from tipping to one side.
- Arrange the ropes so that no components are damaged when the machine is lifted and the ropes do not slip.
- Avoid shocks and vibrations.
- Set up the system on a horizontal, even surface

##### Transport with a fork lift

- Adjust the forks to the maximum distance and secure.
- Slowly lift the machine and transport it horizontally.
- Avoid shocks and vibrations.

- Remove the cover lid from the system
- Attach the hoist (hook) to the transport lug (1)
  - ☞ Be aware of the risk of tipping during lifting
  - ☞ The load pick-up point is not above the center of gravity

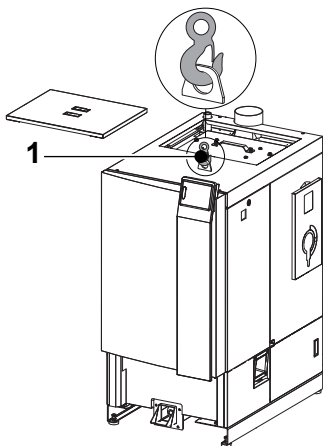

## 6 Setup

There are several ways to transport the system to the boiler room

	<b>NOTE</b>
	For safe transport during installation, do not remove the pallet and cardboard from the system.

☞ Recommendation: Use at least four people to move the system into position

### Transporting the system on rollers

☞ For better rolling, use at least 1" pipes or equivalent

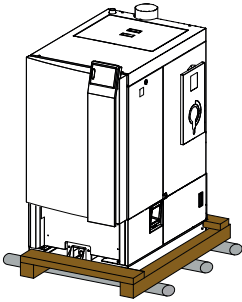

### Transporting the system with a lift truck or forklift

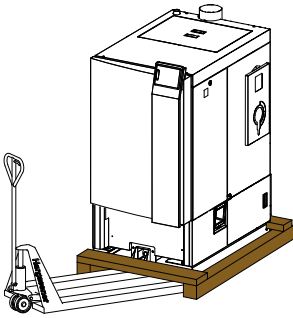

- Position the system in the place provided for this purpose
- Remove the transport timbers from the system

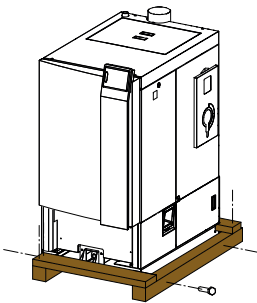

	<b>NOTE</b>
	If space is tight during installation, remove the cover door.

Use at least two people to reduce the transport size.

## 6.1 Removing the cover door

### 6.1.1 Removing the control unit (BCE)



- ❑ Slide the control unit **upwards** until the bottom disengages from the cover

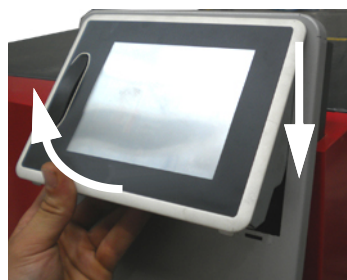

- ❑ Tip the control unit out and pull it downwards out of the cover

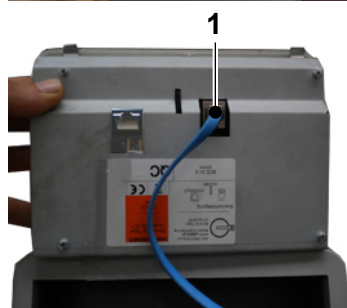

- ❑ Disconnect the BUS connection (**1**) from the rear side of the control unit

- ❑ Pull the blue ribbon cable out of the cover door

- ❑ Put the control unit safely aside



### 6.1.2 Detaching the cover door

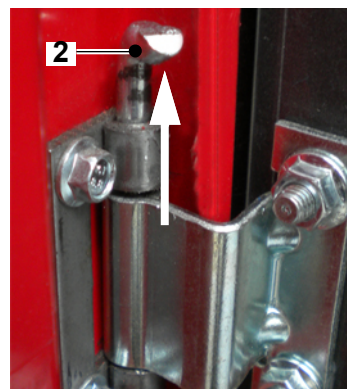

- ❑ Pull the bottom hinge pin first and then the top hinge pin (**2**) up and out of the hinge

- ☞ Secure the door against tipping

- ❑ Remove the cover door and put it safely aside

- ❑ After having positioned the system, install the cover door in reverse order

- ❑ Hang up the door

- ❑ Pull in the BUS cable

- ❑ Install the control unit

## NOTE



Recommendation: Remove the cover door in the same way to fit the trim panel.

## 7 Installing the trim panel

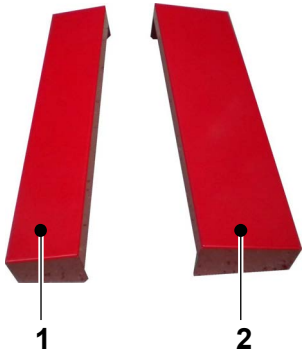

- ☐ Position the trim panels flush with the cover door
- ☞ Narrow trim panel (1) left, wide trim panel (2) right

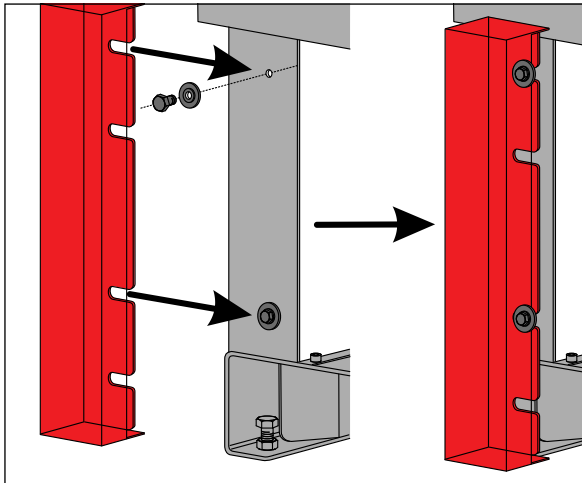

- ☐ Put the trim panels on from the side
- ☐ Use M6x16 screws and plastic washers to fix them in place

## 8 Installing the exhaust fan motor

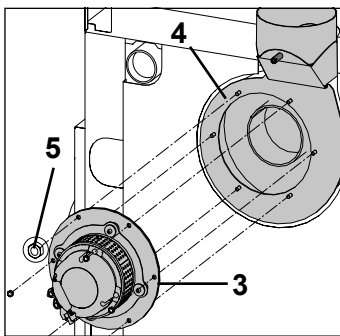

- ☐ Attach the exhaust fan motor (3) to the exhaust fan housing (4)
- ☐ Secure the motor with M8 copper nuts (5)
- ☞ Do not damage the seals on the motor and housing

## 9 Fitting the leveling feet

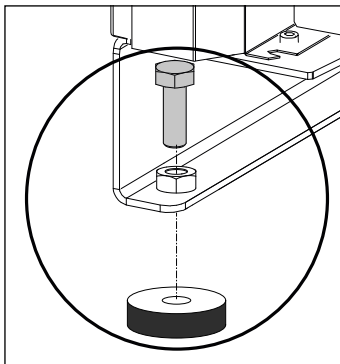

Once the system is in its final position, it needs to be leveled using the levelling feet.

- ☐ Screw the M12x40 screws from the top into the boiler body
- ☐ Position the leveling feet under the screws
- ☐ Lower the system onto the leveling feet
- ☐ Align the system horizontally using the screws

## 10 Installing the stoker unit

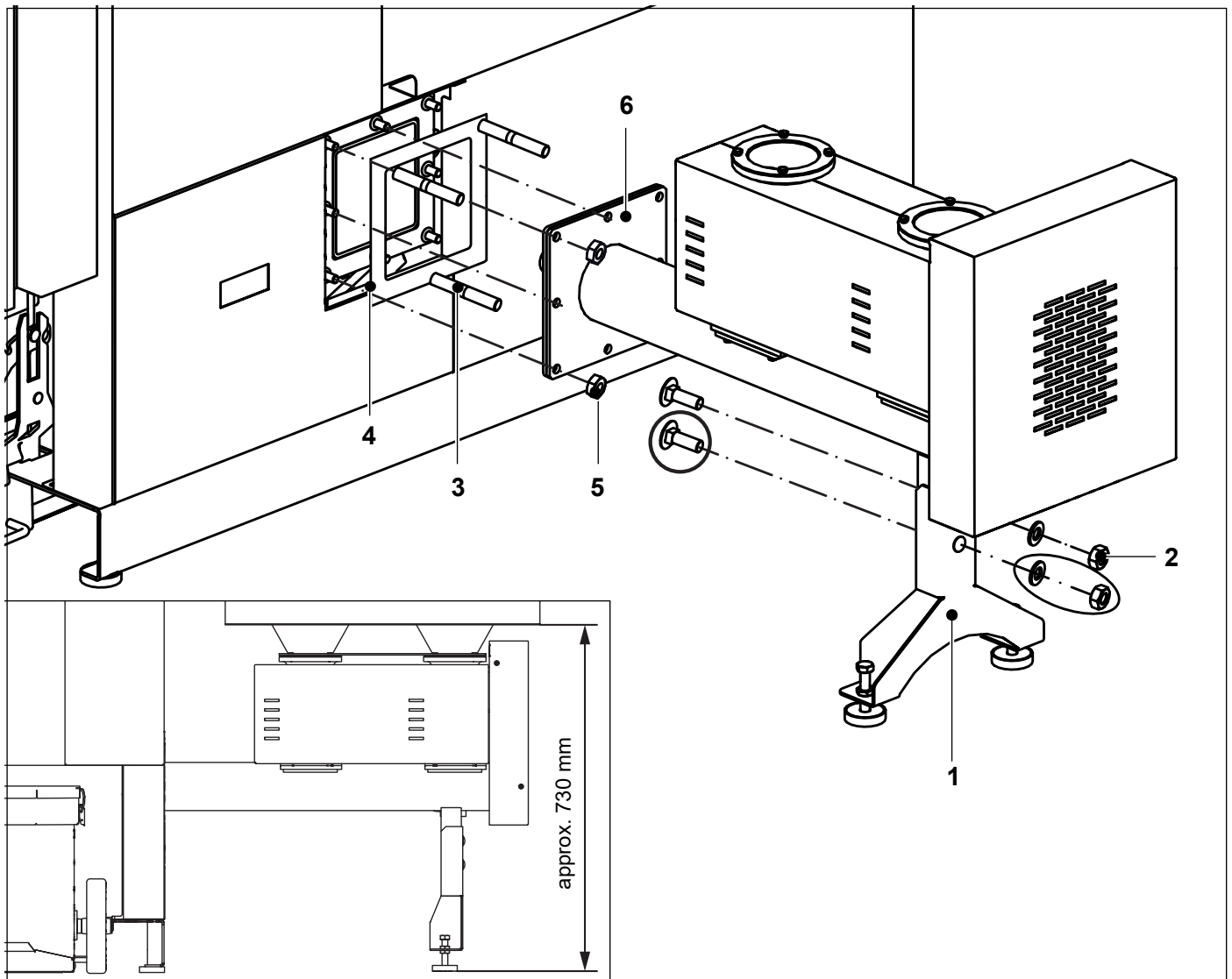

- Put the leveling foot (1) in position and secure in place
  - ☞ Position them according to the height
  - ☞ Distance to the floor (when the base is level): 730 mm
  - ☞ M8x20 mushroom head bolts, M8 washers and M8 flange nuts (2)
- Screw 8 stud screws M10x25 (total length 37 mm) (3) with the **short thread side** (thread length 10 mm) into the boiler flange
- Insert the seal (4)
- Secure the stoker unit (6) to the boiler flange
  - ☞ 8 lock nuts M10 (5)

## 10.1 Installing the pellet day hopper

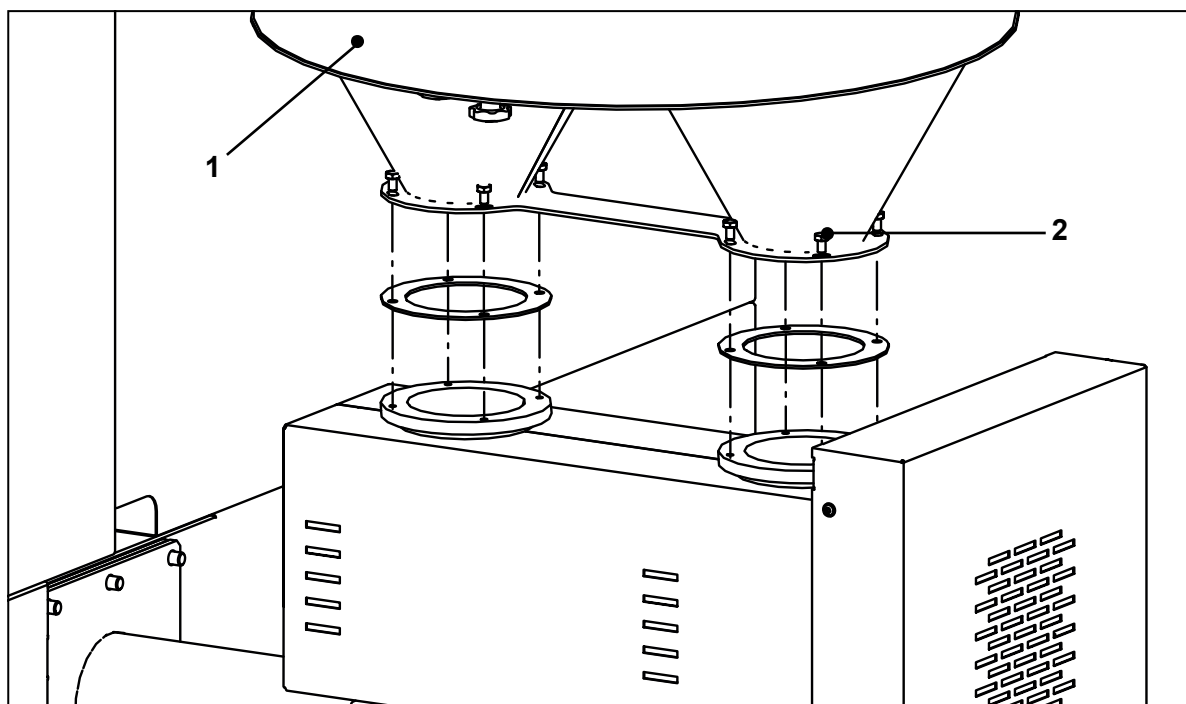

- ☐ Position the pellet day hopper (1) on the stoker unit and secure it (2)

## 11 Mounting instructions for pellet hoses and pellet steel pipes

ATTENTION	
	<p><b>Damage to the system due to incorrect laying of the pellet hoses</b></p> <ul style="list-style-type: none"><li>• Do not kink hoses.</li><li>• Hose temperature resistance: Minimum <math>-5^{\circ}\text{C}</math>, maximum <math>60^{\circ}\text{C}</math>.</li><li>• Do not allow the hoses to touch non-insulated heating pipes.</li><li>• Minimum distance to non-insulated flue gas pipes: 20 cm.</li><li>• Do not install hoses outside in an unprotected condition. Hoses are not UV-resistant.</li><li>• Observe the direction arrows of the return air hose and pellet suction hose.</li><li>• Ensure correct hose routing to overcome different height levels.</li><li>• Only use a single-piece pellet suction hose.</li><li>• Lay the hoses so that they are easily accessible for replacement in the event of wear.</li></ul>

### 11.1 Earthing the pellet hoses and pellet steel pipes

WARNING	
	<p><b>Fire hazard</b></p> <p><b>Fire due to electro-static discharge</b></p> <ul style="list-style-type: none"><li>• Earth the pellet hoses at both ends with the copper wire inside the hoses.</li><li>• When extending the return air hose, use nozzles made of metal.</li><li>• Only connect earthing to bare surfaces.</li></ul>

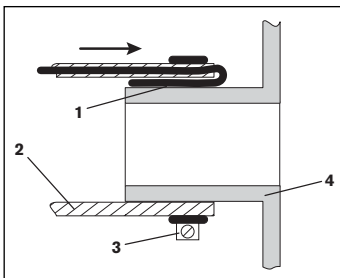



Pellet transport in the hoses causes electrostatic charge.

- Earth the pellet suction hose and return air hose at each fixation to the nozzle (on both ends)
- Pull the copper wire (1) out of the hose (2) and strip approx. 5 cm of the insulation
- Clamp the copper wire between the nozzle (4) and hose
- Insert the hose over the nozzle
- Secure the hose to the nozzle using the hose clamp (3)

#### Earthing with pellet steel pipes

- Bend the wire bracket of the insertion coupling inwards

## 11.2 Marking the pellet hoses

	<b>ATTENTION</b>
	<b>Material damage</b> <b>Damage to the system due to incorrect connection of the pellet hoses</b> <ul style="list-style-type: none"><li>• Connect the pellet hoses according to the direction arrows on the hose nozzle.</li></ul>
	<b>NOTE</b>
	Label the pellet suction hose and return air hose permanently on their respective ends so that they cannot be mixed up. This prevents confusion during assembly or maintenance work.

### 11.2.1 Point extraction RAPS

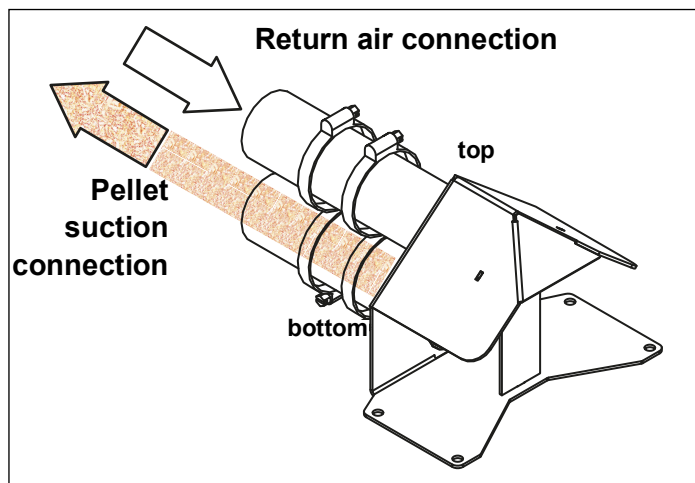

### 11.2.2 Fuel extraction auger RAS

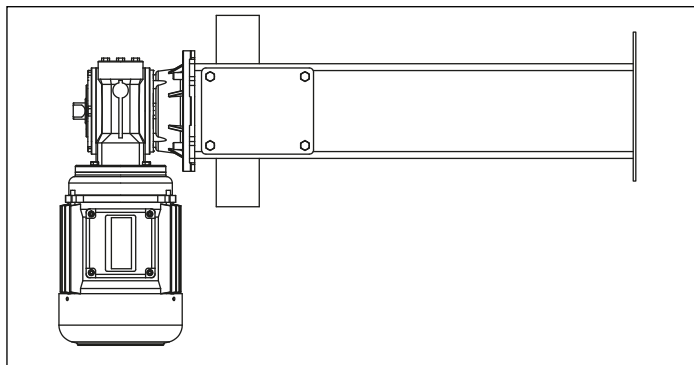

- Connect the pellet hose either on the left or the right nozzle depending on the available space

### 11.2.3 Bag silo GWTS / GWT-MAX

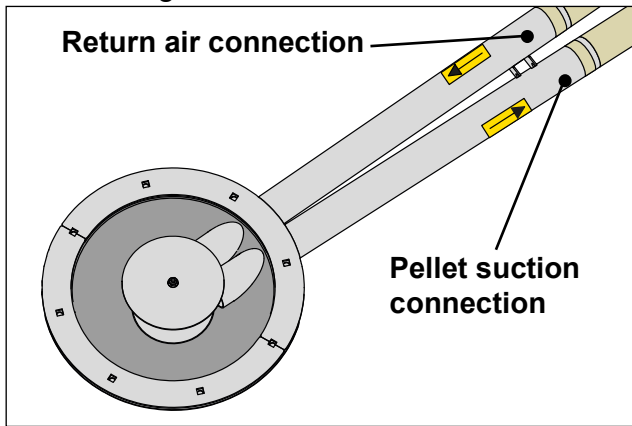

### 11.2.4 PowerBox

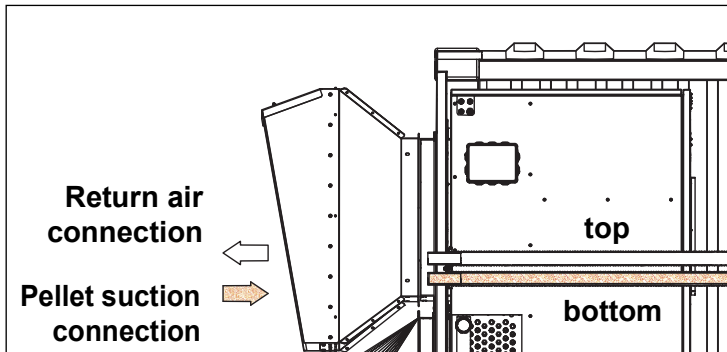

### 11.2.5 Pellets weekly tank PWB and underground pellet tank

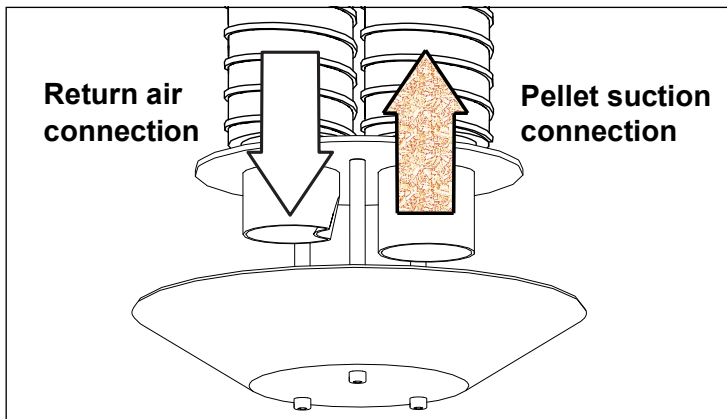

### 11.2.6 Changeover unit AUP

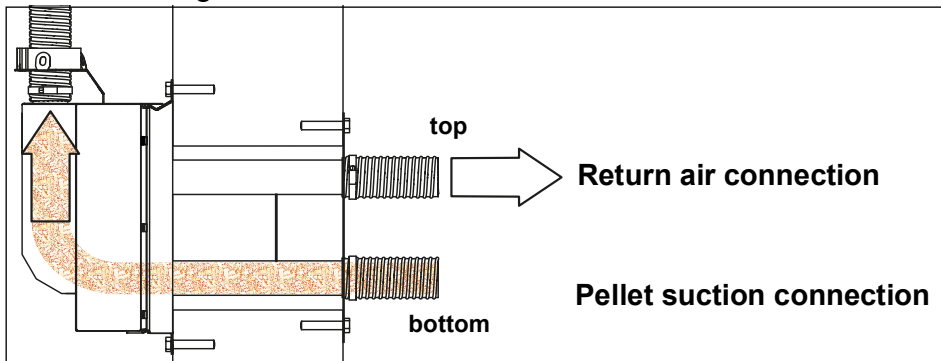

## 11.2.7 Pellet container on the system

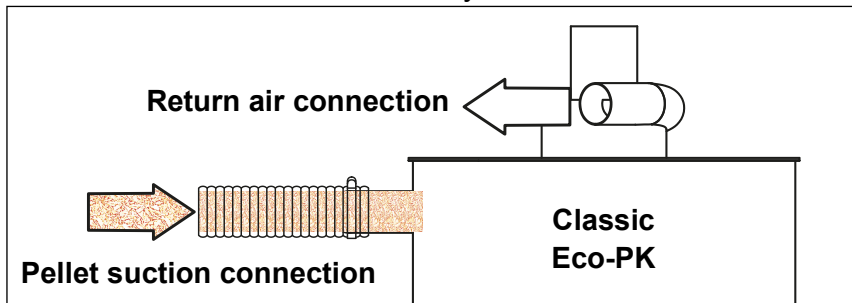

## 11.3 Laying pellet hoses

### 11.3.1 Laying the pellet suction hose

<b>ATTENTION</b>	
	<p><b>Material damage</b></p> <p><b>Blockage and abrasion by pellets during suction</b></p> <ul style="list-style-type: none"><li>• Make sure the laying radius is at least 30 cm over the entire length of the hose (check the radius with the enclosed gauge) or change direction with 90° steel pipe bends.</li><li>• Secure hoses against shifting using pipe clamps.</li></ul>

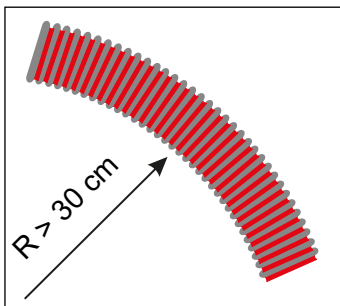

#### Pellet boilers below 70 kW

- Make sure the laying radius is at least 30 cm
  - ☞ The larger the radius, the better the pellet transport is
- Or change direction with 90° steel pipe bends

#### Pellet boilers from 70 kW

- Always install pellet suction hoses perfectly straight
- Only use 90° steel pipe bends to change direction

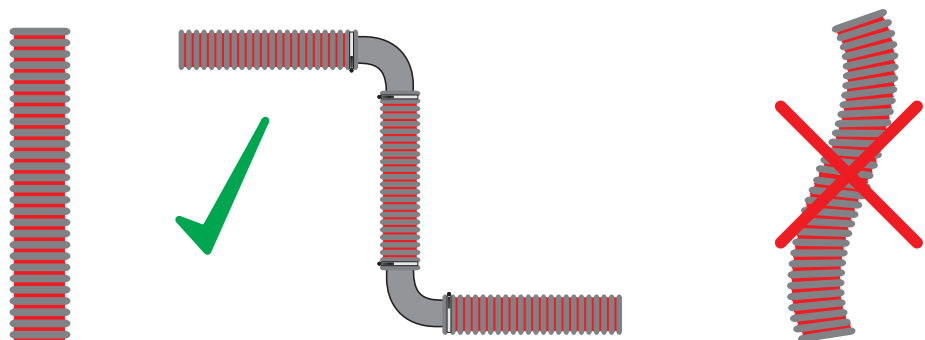

Recommendation: From a boiler output of 130 kW, the pellet suction line should be made entirely of steel pipes.

⇒ "Laying pellet steel pipes", p. 23

### 11.3.2 Laying the return air hose

- ☐ Make sure the laying radius is at least 30 cm
- ☞ Use the enclosed gauge to check this

### 11.3.3 Pellet hose laying diagram/overcoming the height difference

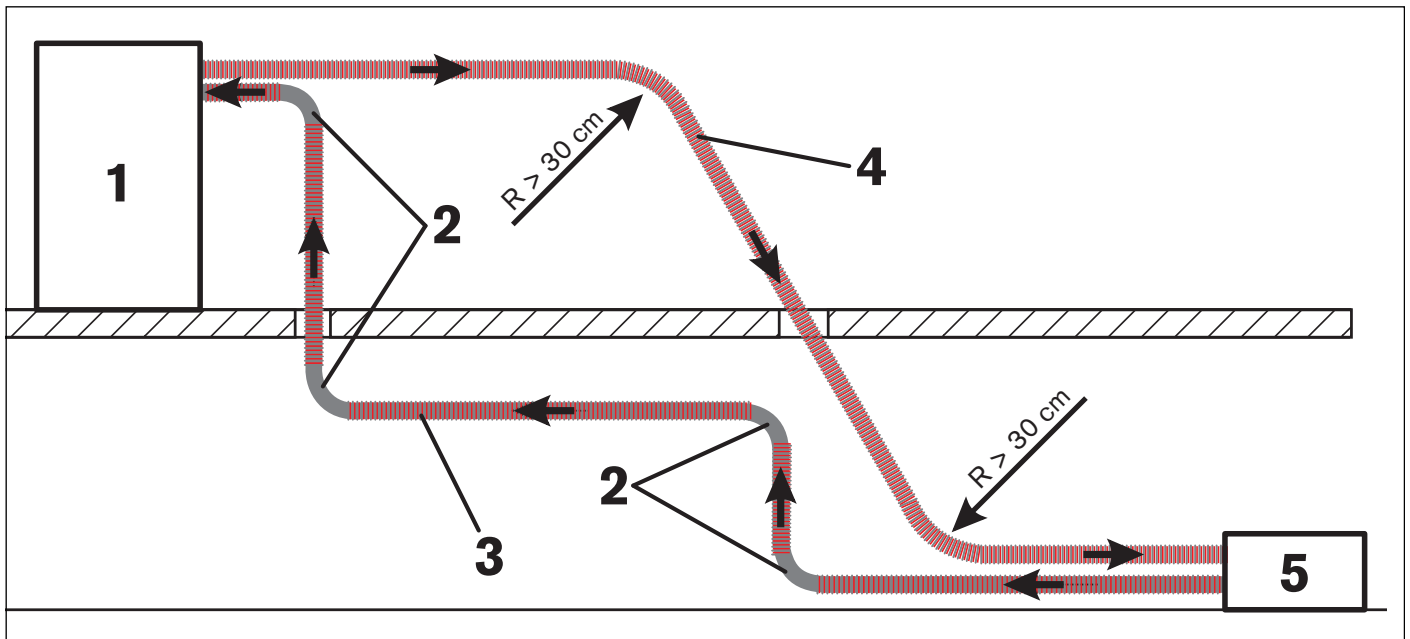

Item	Description
1	Hargassner pellet system
2	R > 30 cm or 90° steel pipe bends
3	Pellet suction hose
4	Return air hose
5	Pellet FE GWT, RAS, RAPS ...

- ☞ The suction turbine is designed to suction the pellets over a length of 20 m with pellet hoses and a height difference of 5 m
- ☞ A maximum of six 90° steel pipe bends can be used for a suction distance of 20 m
- ☞ When using a fuel extraction system RAS, the suction line can be up to 30 m long if the transport auger is cycled in the service settings. For longer or higher transport routes, always contact Hargassner Ges mbH
- ☞ When using point suction systems (RAPS, GWT), the pellets fall back down into the suction hose when the suction turbine stops. These pellets that fall back can block the pellet hose. To avoid this, install horizontal sections to overcome the height difference
- ☞ Use mounting clamps or support shells for better routing of the pellet hoses  
⇒ "Wall fixing elements", p. 25

### 11.3.4 Do not loop the pellet suction hoses

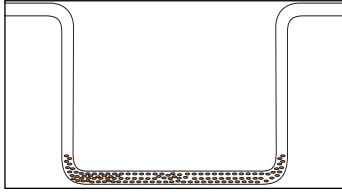

- ❑ Do not form loops (bags) in the hoses during laying
- ☞ Pellets that fall back can block the suction hose

## 11.4 Laying pellet steel pipes

- ☞ For AUP and GWTS/GWT-MAX, the last metre of the pellet steel pipe for connecting to the fuel extraction system must be made with a flexible pellet hose
- ☞ Vibrations and small movements of the fuel extraction system can be better absorbed by flexible hoses

### 11.4.1 Screw connection of the pellet steel pipes

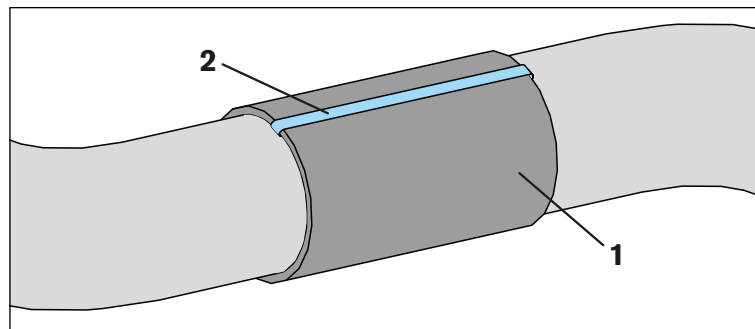

- ❑ Connect both pellet steel pipe elements and position the collar (1) over them
- ❑ Bend the wire bracket (2) inwards

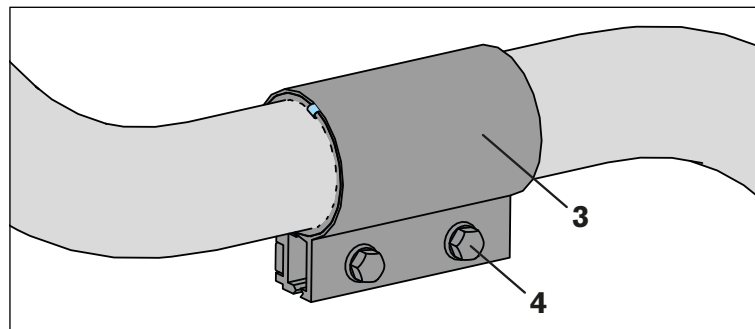

- ❑ Position the pipe coupling (3) over the collar
- ❑ Tighten both screws (4)

## 11.4.2 Basic set for pellet steel pipes

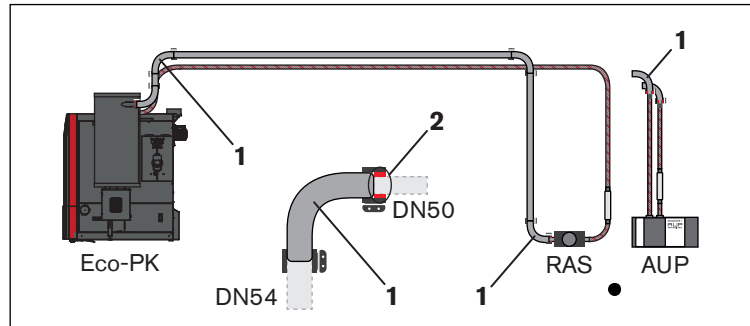

- ☞ Use the basic set (1) when using a pellet container and fuel extraction auger (RAS) or changeover unit (AUP)
- ☞ The insert seal (2) included in the basic set bridges the difference in diameter between the pellet steel pipe, pellet container, RAS or AUP

## 11.4.3 Pellet steel pipe laying diagram/overcoming the height difference

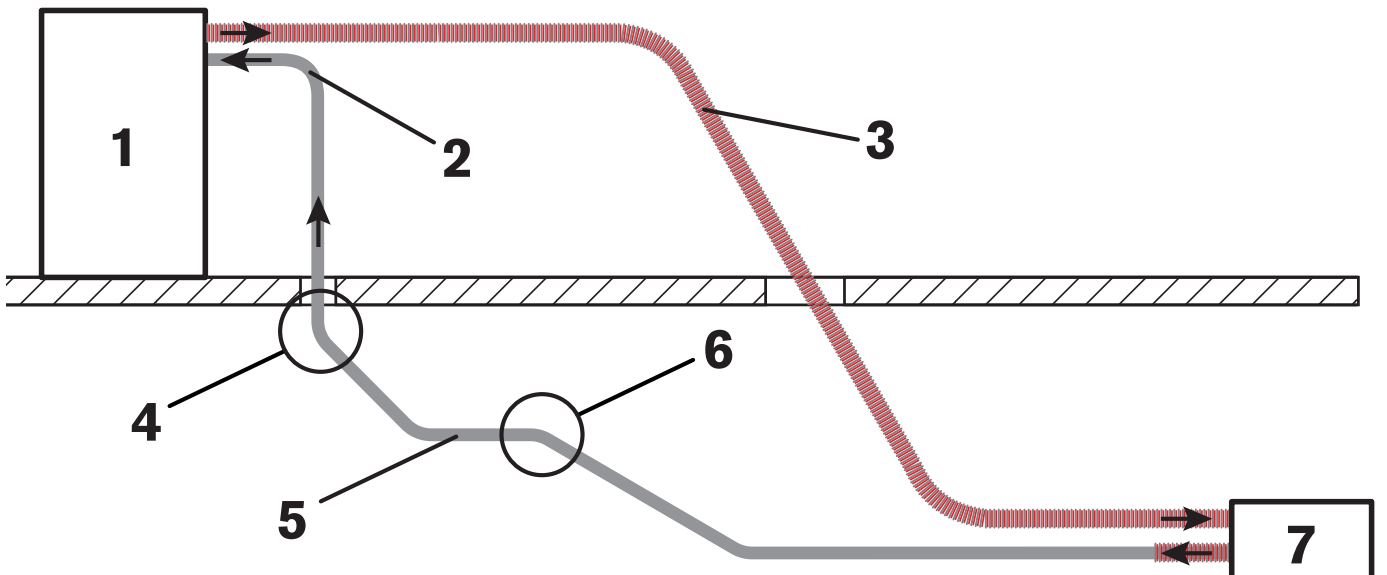

Item	Description
1	Hargassner pellet system
2	90° steel pipe bend
3	Return air hose
4	45° steel pipe bend
5	Pellet steel pipe
6	30° steel pipe bend
7	Pellet FE GWT, RAS, RAPS ...

- ☞ The suction turbine is designed to suction the pellets over a length of 30 m with steel pipes and a height difference of 5 m
- ☞ A maximum of six 90° steel pipe bends can be used for a suction distance of 30 m

- ☞ When using a fuel extraction system RAS, the suction line can be up to 30 m long if the transport auger is cycled in the service settings. For longer or higher transport routes, always contact Hargassner Ges mbH
- ☞ When using point suction systems (RAPS, GWT), the pellets fall back down into the suction pipe when the suction turbine stops. These pellets that fall back can block the pellet steel pipe. To avoid this, install horizontal sections to overcome the height difference
- ☞ Use mounting clamps or support shells for better routing of the pellet steel pipes
  - ⇒ "Wall fixing elements", p. 25
- ☞ Make the wall breakthroughs in accordance with local fire protection regulations

#### 11.4.4 Do not loop the pellet steel pipes

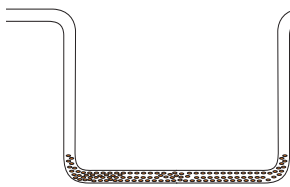

- ☐ Do not form loops (bags) in the pipes during laying
- ☞ Pellets that fall back can block the pellet steel pipe

## 11.5 Accessories for pellet hoses and pellet steel pipes

### 11.5.1 Extension of the pellet hoses

ATTENTION	
	<p><b>Material damage</b></p> <p><b>Damage to the system due to incorrect extension of the pellet hoses</b></p> <ul style="list-style-type: none"> <li>• Do not extend the pellet suction hose. Insufficient pellet transport.</li> <li>• If necessary, extend the return air hose correctly.</li> <li>• Connect the return air hose segments outside the pellet storage room to provide easy access to their point of assembly.</li> <li>• Use a metal extension pipe.</li> <li>• Connect the return air hose earth wire to the extension tube.</li> </ul>

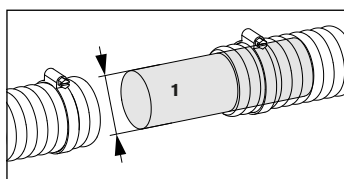

- ☐ To extend the return air hose, insert both hose ends onto a metal tube (1), earth them and secure them with hose clamps

### 11.5.2 Wall fixing elements

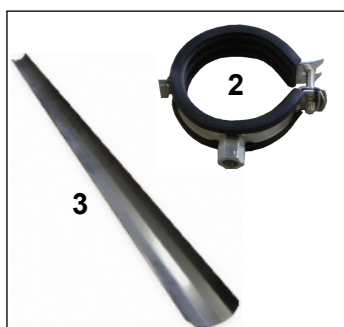

- ☐ Mounting clamps (2) and support shells (3) can be used to easily install the pellet hoses on the wall

---

### 11.5.3 Suction hose bend 90°



- ❑ Use the 90° suction hose bend with screw clamps for very tight curves or outward bends
  - ☞ Always use 90° steel pipe bends to change direction for pellet suction hoses from a 70 kW system output

### 11.5.4 Fire protection sleeve for pellet hoses



- ❑ Mount a fire protection sleeve on each pellet hose for each wall breakthrough

## 12 Ash box

### 12.1 Installing the ash box flange

1. Open the cover door



2. Correctly position the flange on the boiler



3. Secure the flange using 4 M6x16 hexagon socket screws (in the screw package)



## 12.2 Ash box (75L) installation

### 12.2.1 Ash channel cover

- ☞ The ash box is delivered in the same way for left and right boilers. The ash channel cover must be installed in the correct manner for the specific version (left or right)

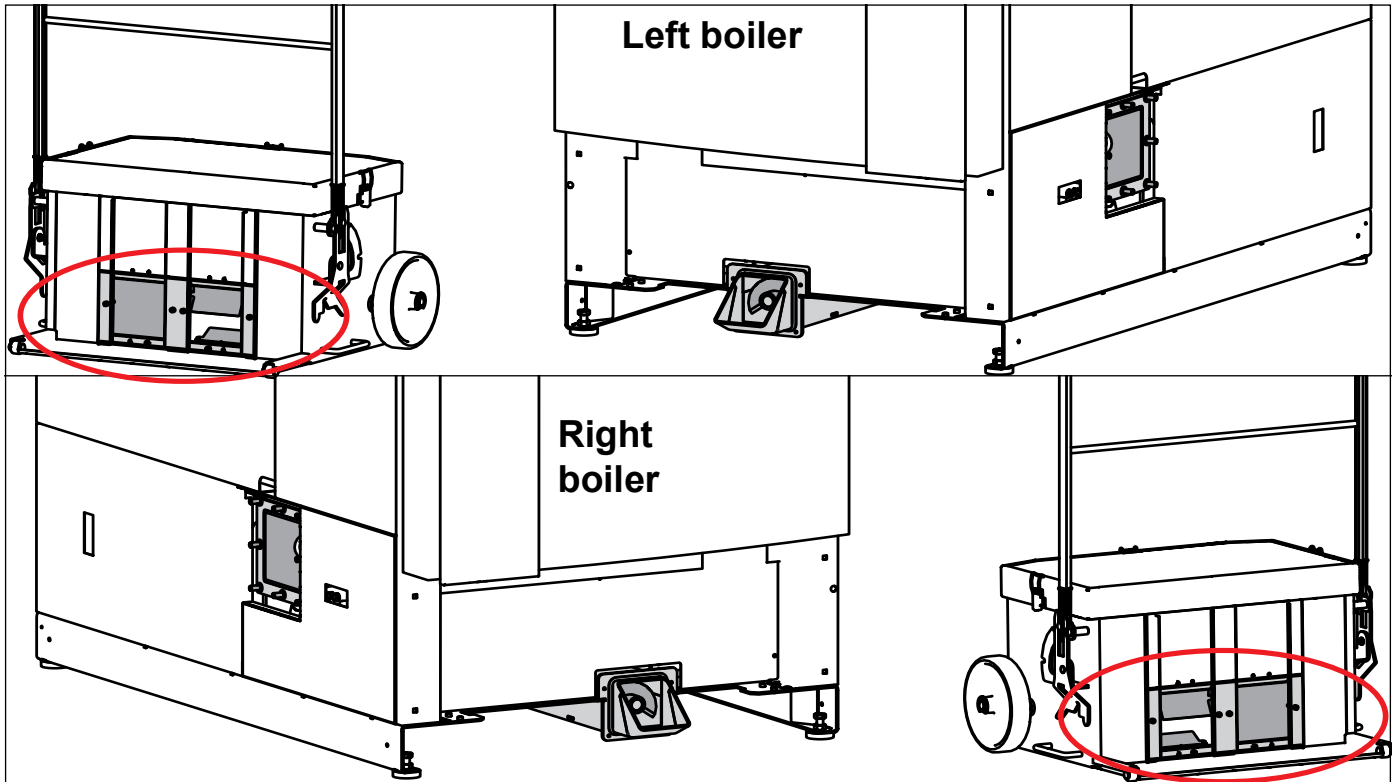

Left boiler

The following installation steps explain how to install the covers for a "left boiler" (installation for a "right boiler" is mirror-inverted)

- ☐ Each cover (flaps and complete cover) is installed using six M5x10 screws and M5 collar nuts
  - ☞ Screws on the outside, nuts on the inside
  - ☞ **Small flap at the bottom, large flap at the top**

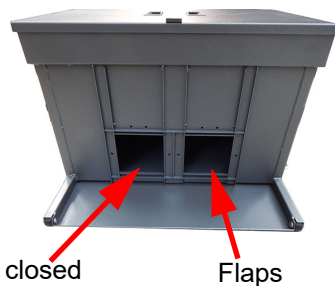

Ash box inside

Flaps  
Top: Large flap  
Bottom: Small flap

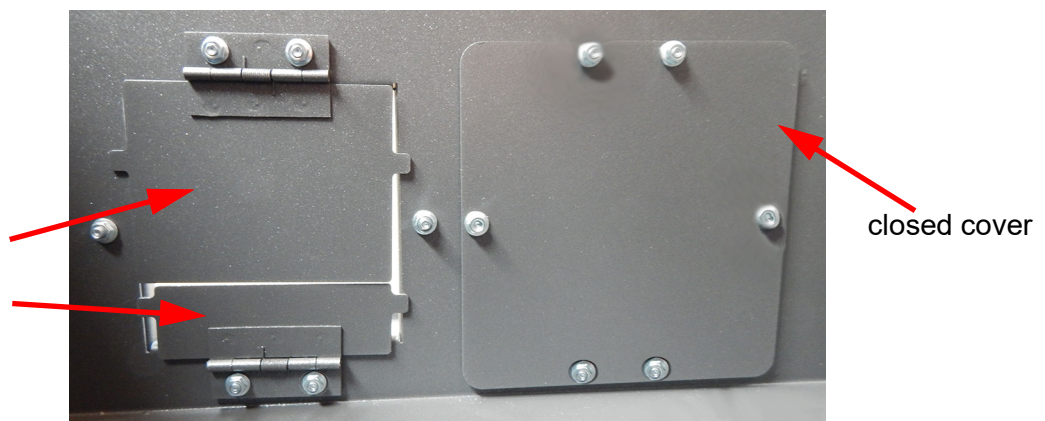

## 12.2.2 Transport handle position

- ☐ In order to change the position of the transport handle, pull the unlocking rod upwards



### 12.2.3 Adjusting the ash box wheels



- ❑ Position the ash box on the boiler and lock in place
  - ☞ Both sides must snap into place



- ❑ Align the ash box using a spirit level

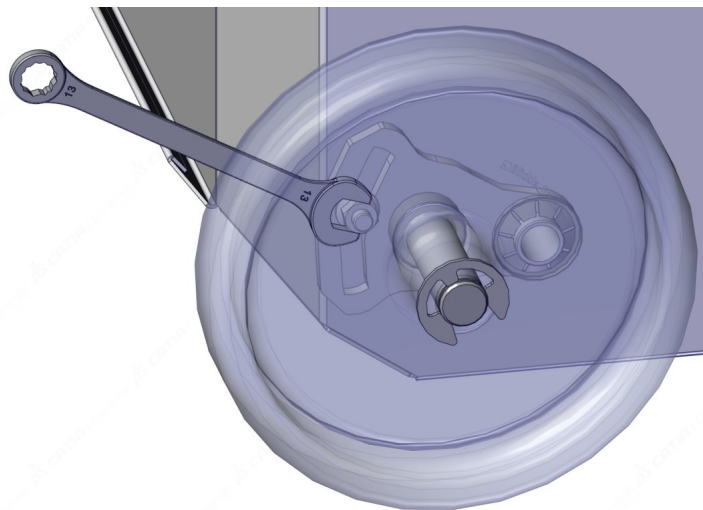

- ❑ Loosen the M8 nut



- ❑ Press the wheel against the floor and tighten the nut

- ❑ Repeat this process on the other side

## 13 Design of the fuel storage room

	<p style="text-align: center;"><b>D A N G E R</b></p> <p><b>Risk of fire, explosion and deflagration</b></p> <p><b>Burns due to explosive burning of dust (pellet dust)</b></p> <ul style="list-style-type: none"><li>• Make sure that the pellet hoses are earthed.</li><li>• No motors in the storage room.</li><li>• No other ignition sources (light) in the storage room.</li><li>• No electrical equipment (switches) in the storage room.</li><li>• No welding works in a dusty environment.</li></ul>
	<p style="text-align: center;"><b>D A N G E R</b></p> <p><b>Risk of suffocation from odorless carbon monoxide</b></p> <ul style="list-style-type: none"><li>• Ventilate sufficiently before entering the storage room.</li><li>• Keep window and door open while inside.</li><li>• Position second person outside to supervise.</li></ul>

Design your fuel storage room in accordance with local regulations (e.g. EN ISO 20023 or VDI 3464).

- A separate fuel storage room is required for fuel quantities  $> 15 \text{ m}^3$ ; see the regulations specific to your country, e.g. TRVB 118 H
- No electrical devices in the storage room; all lines to be installed concealed
- Only install filling sockets and anti-rotation protection that are made from metal and grounded using a bonding conductor
- Consider noise protection for wall openings
- Protection against moisture, water and dust
- Correctly position impact protection mat and install slant floor
- Ventilation of the storage room according to legal requirements

### 13.1 Ventilation of the fuel storage room

☞ Storage rooms and storage containers must be ventilated to prevent a dangerous CO concentration

#### General ventilation functions:

- Ensure the exchange of air between the storage room and ambient air
- Install ventilation lines as short as possible and with as few changes of direction as necessary
  - ☞ Lowest possible pressure loss
- Preferably lead ventilation into the open air
  - ☞ Prevent rainwater entering through ventilation openings
- Design ventilation cross-sections according to local legal requirements
  - ☞ Various cross-sections depending on the size and design of the storage room





## 13.2 Safety in the fuel storage room

Observe the instructions on the fuel storage room sticker.

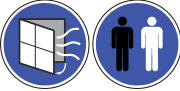

# FUEL STORAGE ROOM

## Pellet storage safety

**DANGER**

	<p>Unauthorized persons are not allowed to enter the fuel storage room. Keep children away! Before entering: Switch off the system with the mains switch on the control unit!</p>
 	<p>Odorless carbon monoxide can be produced in dangerous concentrations in pellet storage rooms.</p> <p>Ventilate the pellet storage room for at least 15 minutes before entering. Carry a CO warning device when entering. Keep doors open whilst in the room and force ventilate the storage room (e.g. with a fan or vacuum cleaner). Always have a second person outside the storage room to supervise!</p>
	<p>Prevent access to the transport auger and other moving parts!</p>
	<p>Do not use an open fire and do not smoke in the area of the fuel storage room!</p>

**WARNING**

 	<p>Make sure you switch off the system before blowing pellets into the storage room! Danger of flue gas being sucked out of the boiler - risk of fire!</p> <p>Protect fuel against moisture!</p>
--	--

- Explain the contents of the sticker to the operator in detail
- Apply the sticker in the access area to the fuel storage room (storage room door, etc.) so that it is clearly visible and is read again before filling the storage room
- Apply the sticker to a flat, well-adhering surface

## 14 Facilities on site

### 14.1 Country-specific regulations

	<b>NOTE</b>
	<p>Observe country-specific safety devices. The regulations and safety provisions for operating combustion systems and storing fuels vary from country to country.</p>

Check country-specific regulations prior to commissioning the combustion system

- ☞ Fire protection
- ☞ Operating combustion systems
- ☞ Storage of fuels
- ☞ Designs of the boiler room and fuel storage room
- ☞ Requirements from chimney sweep

### 14.2 Qualification of installation staff

	<b>WARNING</b>
	<p><b>Risk of injury and/or material damage</b> <b>Risk of injuries and damage due to improper installation</b></p> <ul style="list-style-type: none"> <li>• Work on the electrics, hydraulics, components of the flue gas system, structural measures and measures for fire protection must only be carried out by authorized staff.</li> </ul>

In addition to the operation manual and the binding accident prevention regulations applicable in the country of use and at the place of use, the recognized technical rules for safe and professional work must also be observed.

### 14.3 Fire extinguisher



Install an inspected (every 2 years) fire extinguisher in an easily accessible place outside of the boiler room right next to the boiler room door.

Boiler room size	Amount of extinguishing powder	Certification
< 20 m <sup>2</sup>	6 kg	EN3
20 - 50 m <sup>2</sup>	12 kg	EN3

## 14.4 Designs of the boiler room

- ☞ A boiler room is required for combustion systems with a nominal heating output of over 50 kW
- ☞ Design boiler rooms in accordance with local regulations
- ☞ Ensure fireproof, level and solid floor and ceiling construction
- ☞ Weatherproof and frost-proof (ambient temperatures of up to +40°C)
- ☞ Free of disturbing electrical installations and pipes
- ☞ Do not store any flammable materials near the system

### 14.4.1 Austrian regulations

- Country-specific boiler room regulation
- Ö-Norm M7510 (inspection of heating systems of solid fuels)
- TRVB 118 H (preventive fire protection)
- TRVB 124 F (first and extended extinguishing help)
- TRVB 105 H (fireplaces for solid fuels)
- TRVB C 141 (outdoor storage of solid, flammable fuels)
- Ö-Norm H5170 (heating systems - requirements for building and safety technology as well as fire and environmental protection)
  - Walls and ceilings REI 90 (F90)
  - Doors EI<sub>2</sub>30-C (F30)
    - ☞ Width: ≥ 0.8 m; height: ≥ 2 m
  - Protect storage room against water ingress

### 14.4.2 German regulations

- FeuVO (fire regulation of federal states)

### 14.4.3 Swiss regulations

- A boiler room is required for combustion systems with a nominal heating output of over 70 kW
- VKF (Association for Cantonal Fire Insurance Companies) fire safety guidelines
- ☞ Important points from the VKF "Fire protection guidelines" - version 01.01.2017
  - Doors with EI 30 fire resistance and walls with EI 60 fire resistance
  - Walls behind combustion systems must be made of fire-resistant material and be at least 0.12 m thick

### 14.4.4 Fire resistance of the wall breakthrough

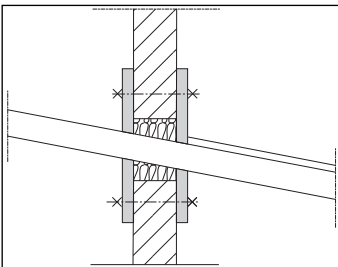

- Ensure that the wall breakthrough complies with the EI 90 fire resistance class
- ☞ Applies if a fuel storage room is required
- Wall opening maximum 50 cm x 50 cm
- Cover with steel sheets (thickness of at least 1.5 mm)
- Cover with fire-resistant plates (thickness of at least 8 mm)
  - ☞ Use at least 10 screws for fixing the cover in place
- Ensure that there is a gap between the wall and the fuel extraction system
  - ☞ Prevents sound transmission
- Filling: fill with rock wool EI 90 (F90)

## 14.5 Ventilation of the boiler room

Air openings must be installed in the boiler room for the firing.

	<b>NOTE</b>
	<p>Please refer to the local regulations for the size of the air openings.</p> <p>Hargassner minimum dimensioning: Provide at least one supply air cross-section of 4 cm<sup>2</sup> per kW nominal boiler output, but at least a total cross-section of 400 cm<sup>2</sup>.</p> <p>It must be ensured that no impairment is caused by air currents or atmospheric influences. If there are cover grilles or similar installed, the cross-section area must be maintained.</p>

## 14.6 Flue connection, flue pipe

Description	Unit	Eco-PK 130	Eco-PK 150	Eco-PK 170	Eco-PK 200	Eco-PK 220	Eco-PK 230
Nominal heating output	kW	130	149	166	199	216	226
Flue gas temperature	°C	150			160		
CO <sub>2</sub>	%	14					
Flue gas mass flow rate	kg/sec	0.0731	0.0836	0.0926	0.1105	0.1200	0.1255
available delivery pressure of fan	Pa	5					
Flue draught max. limit	Pa	10					
Flue pipe diameter	mm	200			250		

The flue gas system must be installed in accordance with local regulations or ÖNORM EN 13384-1.

- The flue pipe is rising towards the flue and should be as short as possible
- Install appropriate openings for cleaning
- Insulate the flue pipe
  - ☞ Protection from hot surface on the flue pipe (risk of burns)
  - ☞ Protection from flammable parts and materials (e.g. electrical wiring)
  - ☞ For reducing condensation
  - ☞ Insulation (foil-laminated rock wool) 30 mm, optimum > 50 mm
  - ☞ Tape joints
- No flammable materials within 20 cm of an insulated flue pipe

## 14.7 Flue draught stabilizer

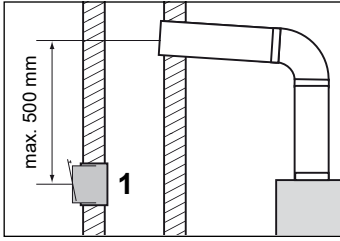

A flue draught stabilizer with an explosion protection flap (1) must be installed in the flue beneath the junction of the flue connection.

- Set the flue draught stabilizer to 10 Pa using the gas meter
- Install the flue pipe rising towards the flue
- ☞ Maximum distance to the flue pipe junction in the flue 500 mm
- ☞ A flue draught stabilizer installed in the flue is beneficial in overpressure situations and when the flue draft is poor

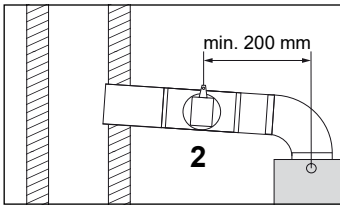

If installation in the flue is not possible, a flue draft stabilizer with an explosion protection flap (2) must be installed in the pipe connecting to the flue.

- ☞ Minimum distance to the flue gas sensor 200 mm

For flue draughts below 30 Pa, the flue draft stabilizer can be shut off.

## 15 Hydraulic installations

- Install the hydraulics according to the enclosed hydraulic schematic (heating schematic)
  - ☞ Design criteria according to EN 12828
  - ☞ Piping and seals must be able to withstand a maximum temperature of 110°C
  - ☞ Note the connection descriptions on the system
- Use an accumulator tank with sufficient volume
  - ☞ A domestic hot water mixer is mandatory for an accumulator tank with integrated domestic hot water coil
- Connect the safety devices
  - ☞ Thermal safety circuit
- Check the opening direction of the mixer
- Install the control valves according to the hydraulic schematic
- Install the sensors according to the hydraulic schematic
  - ☞ "Sensor installation", p. 41
- The chemical and physical properties of heating water must comply with country-specific standards (EN 12828, ÖNORM H 5195-1, VDI 2035, SWKI BT 102-01, SIA 384)
- The electrical conductivity of the heating water should be between 20 and 200 µS
- When filling with heating water, no air must enter the heating system - vent the filling hose before connecting it
- Only use approved heating filling devices for filling with heating water

## 15.1 Back-end protection unit

	ATTENTION
	<p><b>Material damage</b></p> <p><b>Damage to the system due to aggressive condensate</b></p> <ul style="list-style-type: none"> <li>• Install the back-end protection properly and according to the hydraulic schematic.</li> </ul>

If the system drops below the dew point, condensation water will form. This combines with combustion residues to form an aggressive condensate and leads to corrosion in the boiler.

- ☞ As long as the temperature of the heating water return to the system is below the minimum return temperature for the boiler, the boiler's flow heating water is added
  - ☞ Regulation to constant return temperature
  - ☞ An admixture is almost always used

### 15.1.1 Hargassner back-end protection unit

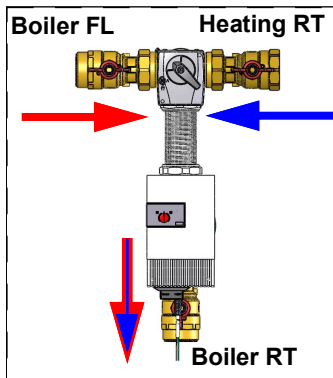

- ☞ Install the back-end protection unit on the side of the boiler
  - ⇒ See enclosed installation manual
- ☞ Be aware of the mixer direction

The mixer is **closed** when the system circuit is closed or the mixer is **open** when the system circuit (RT) is open.

During operation, the return temperature increases when the mixer **closes** and it decreases when the mixer **opens**.

- Install a venting device
- Vent the pump

### 15.1.2 Position of the cock plug

↙

Position of the cock plug

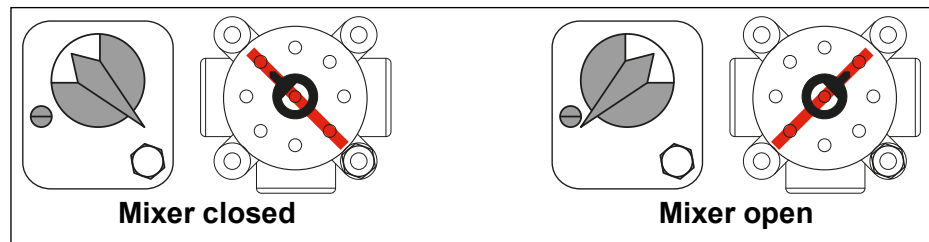

- ☞ The mixer is **closed** when the system circuit is closed
  - ☞ Maximum back-end protection, no energy for heating
- ☞ The mixer is **open** when the system circuit is open
  - ☞ Minimum back-end protection, maximum energy for heating. During the heat-up phase, the mixer moves to the **closed** position to reach the return temperature as quickly as possible. Once the return temperature has been reached, the system control will open the mixer valve to maintain a constant return temperature

### 15.1.3 Back-end protection on site

RAG - bauseits / on site /  
Sans Groupe de Recyclage /  
no incluido / in loco

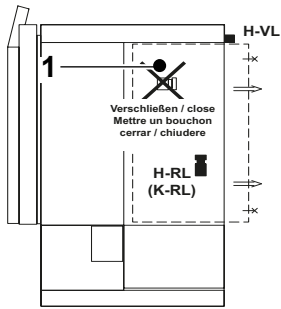

- Remove the side boiler cover
- Seal unused connection (1)
  - ☞ Be aware of the mixer direction
- Install a venting device
- Vent the pump

### 15.2 Domestic hot water mixer

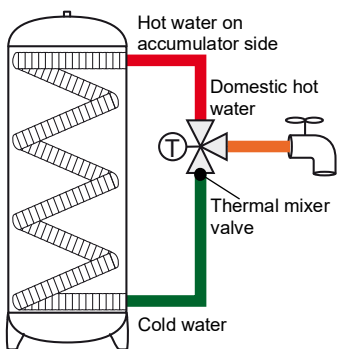

Hot water heating using an accumulator tank with an integrated domestic-hot-water coil, an integrated HWT or an external HWT.

- ☞ To protect against scalding, a thermal mixer valve must be installed

### 15.3 Safety valve

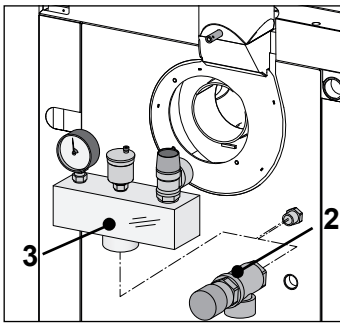

- Connect the safety valve (2) or the safety group (3) (up to 200 kW) to the rear side of the boiler
- Check for leaks

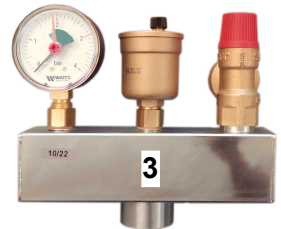

### NOTE



To ensure safe drainage after the safety valve has been triggered, a hose or piping must be connected that leads into the drain.  
The drain with drain funnel must be free to inspect in order to detect any leaks (dripping) of the valve.

## 16 Electrical installations



### DANGER

#### Danger to life

##### Electric shock from contact with live terminals

- Observe information signs.
- Before starting work, check that no voltage is present using a voltmeter.

A detailed electrical manual is enclosed to help with the electrical installation.

- Wiring diagram
- Electrical diagram of the sensors, motors, pumps, mixers, proximity switches
- Information regarding connecting the main power switch in front of the boiler room door
- Instructions on extending the cables

#### Working on the system's electrical equipment

- The electrical connection has to be executed according to the enclosed electrical manual through a licensed and authorised electrician
- Connect equipotential bonding conductor
- Suction hoses (if used) must be earthed (see sticker)



### WARNING

#### Fire hazard

##### Risk of injuries and damage from flammable material

- During the electrical installation process, be aware of the position of the flue pipe.
- The insulation of cables and cable shafts is flammable.
- The distance from electrical wires to the bare flue pipe must be at least 40 cm.

When laying the electrical cables outside the system (main connection, sensors, pumps, mixer control), make sure you observe the minimum distance to the hot flue pipe and exhaust fan.

- Power supply to the control unit
- Protection of the power supply with back-up fuse according to electrical diagram
  - ☞ Note the instructions in the wiring diagram
- Main heating switch (emergency stop) in front of the boiler room door
  - ☞ Install a horn or warning light so that it can be noticed easily and reliably
  - ☞ Complete disconnection of the electrical power supply to the control unit
- Connection of all necessary safety equipment
  - ☞ All sensors for safe operation of the system(according to wiring diagram)
- Connections of heat circuits (pumps, mixers, sensors)
- Install outside temperature sensor
  - ☞ Do not install in direct sunlight
- Connect the earthing terminal on the system to the protective earth conductor in the control cabinet

## 16.1 Installing the main power switch

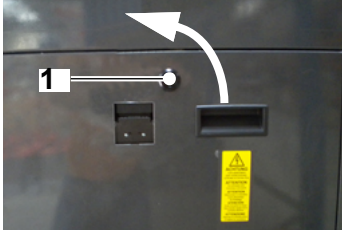

- Open the turn-type lock **(1)** using the plastic key (on the combustion chamber door handle)
- Open and remove the cover from the control box

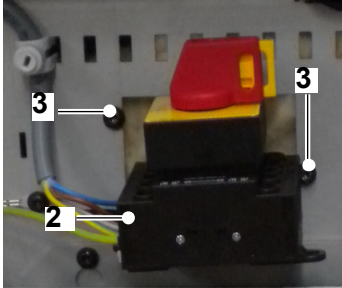

- Loosen two self-tapping screws **(3)** on the board base plate

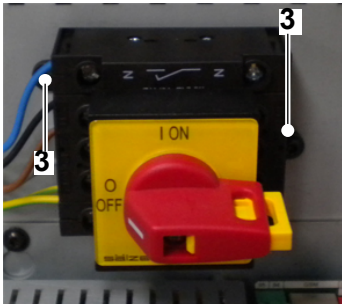

- Remove the main power switch **(2)** and position it correctly
  - ☞ Position **On** must be at top
- Fix the main power switch at the two fastening points on the board base plate
  - ☞ 2 self-tapping screws **(3)**
- Refit the cover on the control box
- Lock again using the turn-type lock
  
- Turn the main power switch **(2)** to position **0**
- During installation, keep the machine locked to prevent any unexpected movements
  - ☞ Keep the key in a safe place

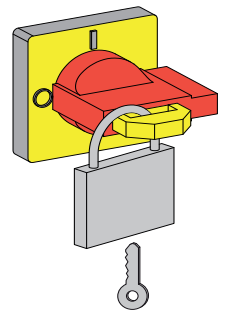

## 16.2 Cable installation

- Connect the cables and sensors according to the enclosed electrical manual

## 17 Sensor installation

### 17.1 Outdoor sensor

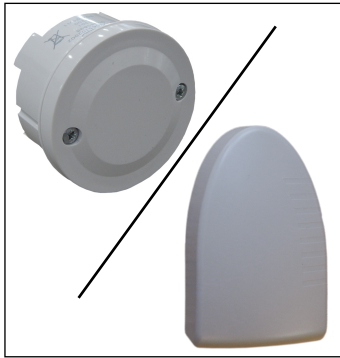

#### Position

- Coldest side of building away from the sun (North; North-East)
- Installation height min. 2 m
- On insulated external walls
- Check for external heat sources (falsification of measured values)
  - ☞ Flue, warm air from air ducts, windows and doors
- Cable outlet from sensor on bottom
  - ☞ Prevent moisture ingress
- Electrical installation with 2-pin cable
  - ☞ See the wiring diagram for the minimum cross section

### 17.2 Flow, accumulator and external heat sensors



According to the hydraulic schematic  
Temperature sensors (except the flue gas sensor) designed as a PT 1000 immersion sensor with a pre-connected sensor cable.

- ☞ Do not damage or bend the sensor cable
- ☞ When extending the cable, bear the minimum cross section in mind

#### 17.2.1 Flow sensor for heat circuits

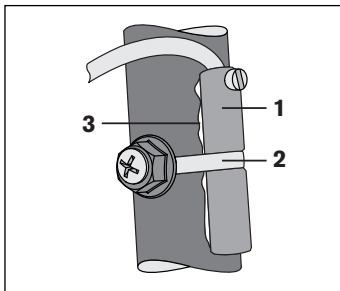

#### Position

- Approx. 50 cm after the circulating pump
- Metallic bare pipe surface
- Secure with enclosed installation material
  - Brass housing (1) and tightening strap (2) or
  - clamp (4)
- Before installing the sensor, apply the heat conducting paste (3) to the point of contact to ensure better heat transfer

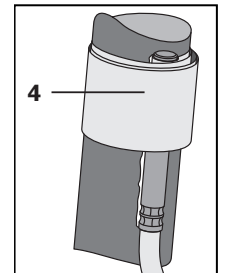

#### 17.2.2 Flue gas sensor

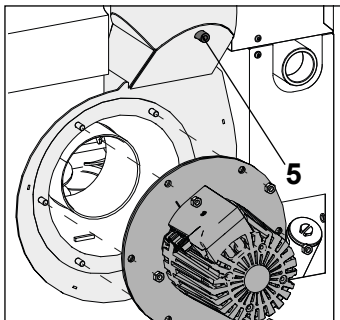

Designed as a thermocouple (type K) with a pre-connected sensor cable.

- ☞ Do not damage or bend the sensor cable
- ☞ When extending the cable, bear the minimum cross section in mind
- Insert the sensor tip into the opening (5) on the exhaust fan and secure with the spring

### 17.2.3 Boiler, HWT, accumulator and external heat sensors

- Install the sensor using the immersion sleeve
- Position the accumulator- and HWT sensor

	NOTE
Correctly position the sensors in order to control the HWT and accumulator loading processes.	

#### External HWT

Sensor resistance values

Boiler, HWT, accumulator, flow, return, outside and external heat sensors	
in °C	in Ohm
-20	922
-10	960
0	1000
10	1039
15	1058
20	1077
25	1097
30	1116
35	1136
40	1155
45	1174
50	1193
55	1213
60	1232
65	1252
70	1270
75	1290
80	1309
85	1328
90	1347
95	1366
100	1385
<b>Room temperature sensor</b> (FR25 remote control) Automatic switch position (clock) and central position of the remote adjuster (regardless of room temperature)	
<b>3340 - 3650 Ω</b>	

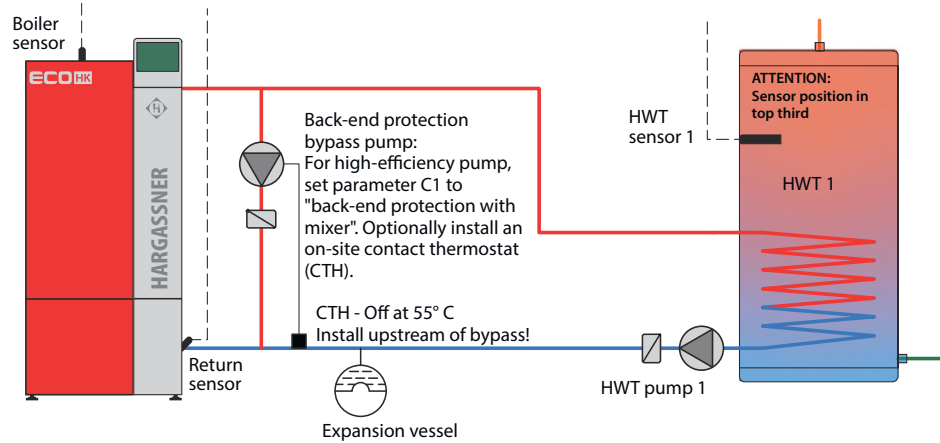

#### Accumulator and external HWT

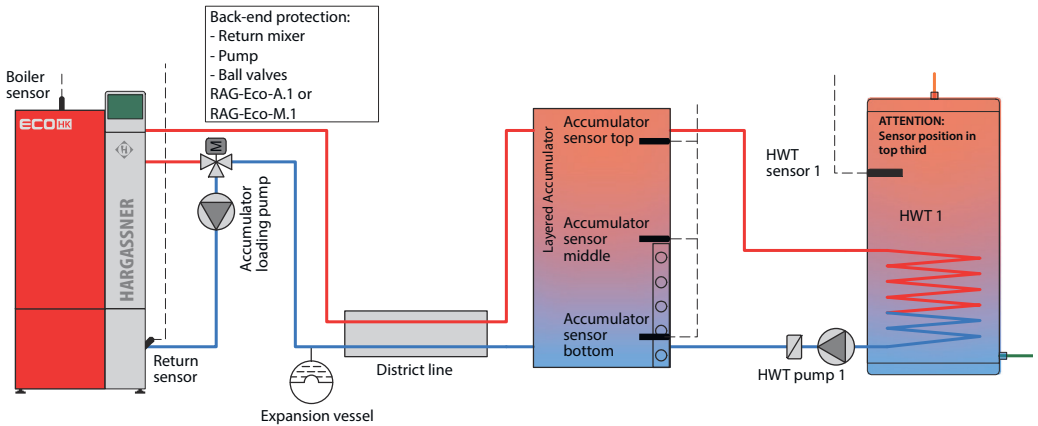

## 18 Remote control FR25 / FR35 / FR40

☞ For professional installation and operation of the remote control, see the installation and operating instructions of the respective remote control

**Caution:** In the installer settings, the corresponding remote control must be parameterised to the assigned heat circuit.

Install the remote control at an easily accessible position

### Place of installation

- No direct sunlight, draught, radiators, flue, etc.
  - ☞ Measurement of the actual room temperature
- In the most appropriate room (e.g. living room or dining room)
  - ☞ No stove (e.g. a tiled stove) may be heated in this room
  - ☞ Set the radiator thermostat to a temperature higher than the room temperature on the control unit
  - ☞ Influences the room sensor
  - ☞ Heat circuit flow is adjusted, causing other rooms to become too cold or too warm

### 18.1 FR25 remote control (analogue)



Can be used for heat circuits connected to the HKM or HKR (not for heat circuits of heat circuit board A).

#### Remote control with room sensor

Connect terminal 1 and 2 (for FR25)

#### Remote control without room sensor

Connect terminal 1 and 3 (for FR25)

#### Fault lamp

The FR25 remote control has a red LED, which can be connected to the boiler. This LED lights up on the control unit when a warning or an error is displayed.

Connect terminal 4 (+) and 5 (-) (for FR25)

### 18.2 FR35 remote control (digital)



Can be used for all heat circuits (HKM, HKR and HC A).

Bus cable 2x2x0.5 mm<sup>2</sup>, shielded and pair-twisted (e.g.: LiYCY)

☞ For cable lengths from 100 m, a cross-section of 0.75 mm<sup>2</sup>

### 18.3 FR40 remote control (digital)

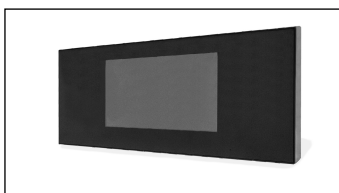

Can be used for all heat circuits (HKM, HKR and HC A).

Bus cable 2x2x0.5 mm<sup>2</sup>, shielded and pair-twisted (e.g.: LiYCY)

☞ For cable lengths from 100 m, a cross-section of 0.75 mm<sup>2</sup>

## 19 Extension module, board or controller

### 19.1 Heat circuit modules 0, 1, 2



Up to 3 heat circuit modules may be connected to extend heat and HWT circuits. The connection to the boiler board is formed by a bus cable (on the CAN plug).

- Set the address selection switch on the extension module (default: **0**)
  - **0** for HKM 0 = heat circuit 1+2 and HWT circuit 1
  - **1** for HKM 1 = heat circuit 3+4 and HWT circuit 2
  - **2** for HKM 2 = heat circuit 5+6 and HWT circuit 3

### 19.2 Additional board I/O 36 (HC AB/F, 5-sensor accumulator or differential controller)

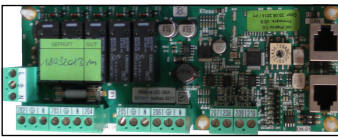

The heat circuit board is for the extension of HWT and heat circuits on the boiler. The connection to the boiler board is formed by a bus cable.

- Default address switch of the heat circuit board
  - **A** for HC A = heat circuit A and HWT circuit A
  - **B** for HC B = heat circuit B and HWT circuit B
  - **C** for AS board = 5-sensor accumulator
  - **D** for D control board = differential controller
  - **F** for HKF = controlled district line

### 19.3 Heat circuit controller HKR



Up to 16 heat circuit controllers can be connected to extend the heat and HWT circuits, as well as accumulator tanks and external heat boilers. The connection to the boiler board is formed by a bus cable (on the CAN plug).

- Set the address selection switch on the heat circuit controller (default: **1**)
  - **0** for HKR 0
  - **1** for HKR 1, etc.

## 20 Permits and reporting requirements

**Caution: Have the installation or conversion of a heating system approved by the relevant regulatory authority.**

- Report any installation or conversion to the supervising office
  - ☞ Austria: Responsible building authority
  - ☞ Germany: Chimney sweep or building authority
  - ☞ Other countries: Observe the regulations of the local authorities

## 21 Commissioning the system

	<b>D A N G E R</b>
	<p><b>Risk of injury and/or material damage</b></p> <p><b>Injuries or damage to the system due to unauthorised commissioning</b></p> <ul style="list-style-type: none"><li>• Make sure that start-up or initial commissioning is performed by Hargassner GmbH or specially trained staff.</li><li>• Prevent unauthorised commissioning.</li><li>• Do not perform any work on the system.</li><li>• Only operate the system independently after a commissioning report has been signed.</li></ul>

---

**notes**

---

**notes**

---

**notes**

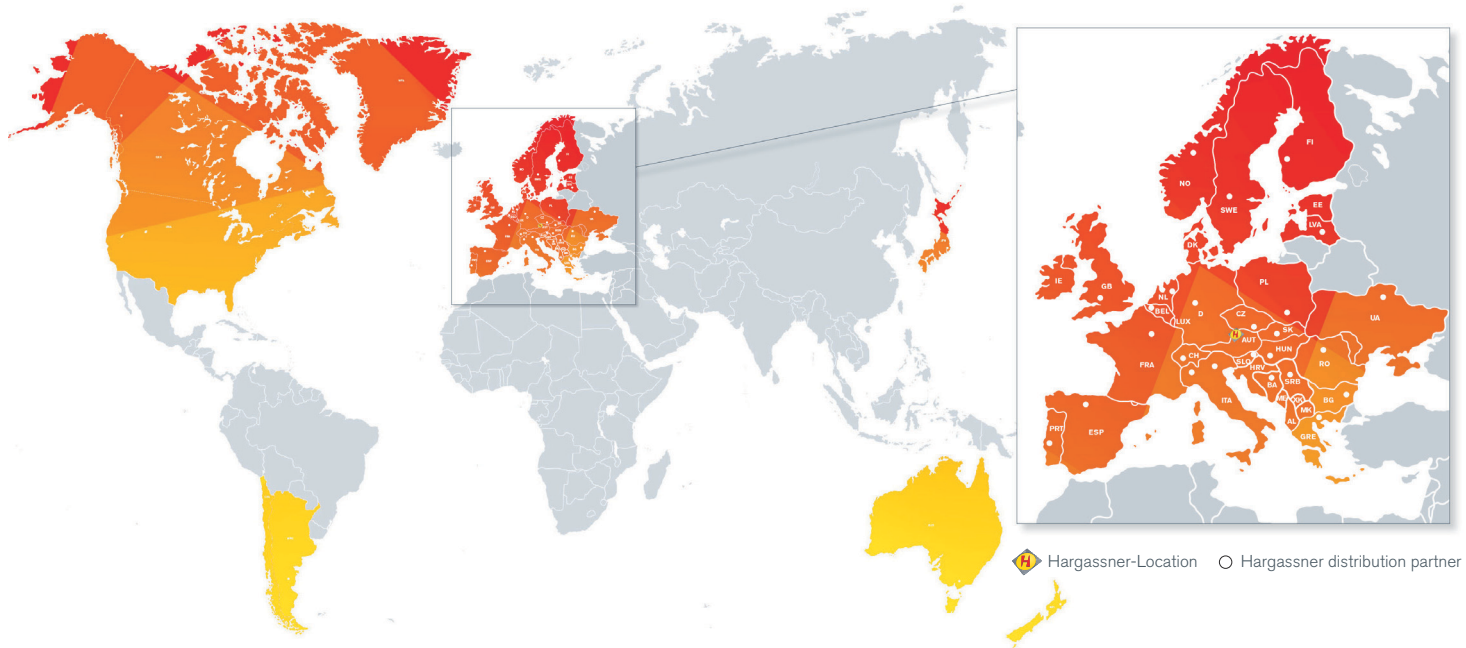

## Your expert for **SUSTAINABLE HEATING**

Complete Hargassner range: pellet boilers, wood chip boilers, wood log boilers, accumulator tanks, industrial boilers up to 2.5 MW, heating modules, filling augers, Power-Box warm-air module, heat pumps, solar panels and hydraulic accessories

**HARGASSNER Ges mbH**  
Anton Hargassner Straße 1  
4952 Weng im Innkreis  
AUSTRIA  
+43 77 23 52 74 - 0  
office@hargassner.at

[hargassner.com](http://hargassner.com)