

# Operation manual Pellet boiler Eco-PK 130-230

**HARGASSNER**  
HEIZTECHNIK DER ZUKUNFT



**Follow and store this manual**

## **HARGASSNER Ges mbH**

A 4952 Weng, Upper Austria  
Tel.: +43/7723/5274-0  
Fax.: +43/7723/5274-5  
office@hargassner.at  
www.hargassner.com

**EN - V05 05/2023 - 11059618**

## Contents

---

<b>Chapter I: Technical Data</b>	<b>5</b>
1 Dimensions	5
2 Intended use	5
3 Seasonal space heating emissions	5
4 Fuel quality	5
5 Boiler room design	6
6 Design of the fuel storage room	6
7 Design of heat circuits	8
8 Back-end protection unit	8
9 Flue pipe - chimney connections	8
10 Electrical supply	8
<b>Chapter II: Safety regulations</b>	<b>9</b>
1 General safety regulations	9
2 Remaining risks	10
3 Measures in case of danger	12
<b>Chapter III: Operation</b>	<b>13</b>
1 Overview of boiler components	13
2 Prior to commissioning	14
3 Control unit	16
4 Operating modes	19
5 System status indicators	20
6 Info menu	22
7 Manual operation	26
8 Settings menu	30
9 Customer settings	33
10 Commissioning settings	39
11 Optional remote controls	53
<b>Chapter IV: Cleaning</b>	<b>55</b>
1 Maintenance contract	56

<b>2 Weekly/monthly cleaning</b> . . . . .	<b>57</b>
<b>3 Annual cleaning</b> . . . . .	<b>58</b>
<b>4 Disposal information</b> . . . . .	<b>66</b>
<b>Chapter V: Troubleshooting</b>	<b>67</b>
<b>1 Information and error display</b> . . . . .	<b>67</b>
<b>2 Viewing the error list</b> . . . . .	<b>67</b>
<b>3 Acknowledging and rectifying an error</b> . . . . .	<b>67</b>
<b>4 BCE failure.</b> . . . . .	<b>68</b>
<b>5 Temporary emergency operation (restart without HW test)</b> . . . . .	<b>68</b>
<b>Appendix</b>	<b>69</b>
<b>1 Copyright notice</b> . . . . .	<b>69</b>
<b>Declaration of Conformity</b> . . . . .	<b>70</b>

---

## Dear customer!

Thank you for choosing an innovative wood biomass boiler from our company. This boiler from Hargassner Ges mbH is a state-of-the-art product and manufactured to the latest production standards. We are very pleased about your decision and guarantee that you've chosen a reliable quality product.

However, as important as the products' high performance is, a professional installation, commissioning and service is just as crucial. Supportive are attached hydraulic schematics, and connections- and installation drawings. To ensure a long service life, exactly read and follow this operation manual. High costs for reparation and long downtimes may be prevented.

### Keep this manual within easy reach.



This operating manual is intended to help:

- you familiarise yourself with the boiler
- you use it for its intended purpose

This manual contains important information on operating the boiler

- Safely
- Properly
- In an environmentally friendly manner
- Economically

Guidelines within this manual will:

- Prevent hazards
- Reduce breakdowns and wear
- Increase the reliability and lifetime of the boiler

# Chapter I: Technical Data

## 1 Dimensions

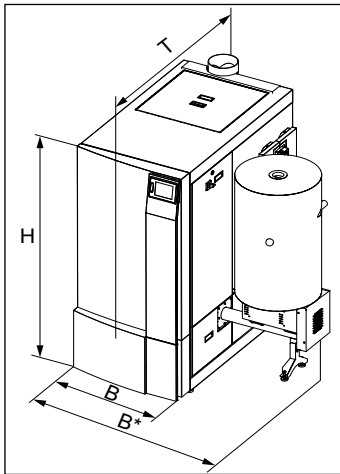

Dimensions in (..) valid for Eco-PK 200-230

Designation	Description	Value	Unit
B	Total width including day hopper	875 (945) 1655 (1725)	mm
T	Total depth	1740 (1905)	mm
H	Total height	1765 (1915)	mm
	Total weight	1190 (1320)	kg

## 2 Intended use

The automatic wood pellet boiler is designed to heat up water only. Only fuels permitted by Hargassner may be burned in this system. Only use the boiler in technically perfect working order. Rectify errors immediately. Intended use also includes observing all items in this manual and adhering to the inspection and maintenance instructions.

## 3 Seasonal space heating emissions

Carbon monoxide	< 500 mg/m <sup>3</sup>
Nitrogen oxide	< 200 mg/m <sup>3</sup>
Gaseous organic compounds	< 20 mg/m <sup>3</sup>
Dust	< 40 mg/m <sup>3</sup>

Seasonal space heating emissions at 10% residual oxygen in dry flue gas

## 4 Fuel quality

Only use fuels that comply with **EN ISO 17225-2**

	<b>NOTE</b>
	Only use fuels approved and permitted by Hargassner Ges mbH. Have new fuels and feasibility checked and approved by Hargassner Ges mbH.

### 4.1 Pellets (A1)

Ensure quality standards are adhered to when pellets are ordered and delivered

- Least possible dust content
- Pellets with a hard and shiny surface
- 100% natural wood, no additives, etc.
- Pellets class **A1** defined in **EN ISO 17225-2** and **EN ISO 20023**

Calorific value	Bulk density	Diameter	Length	Fine material rate
≥ 4.6 kWh/kg	600 - 750 kg/m <sup>3</sup>	6 ±1 mm	3.15 - 40 mm	≤ 1%

# I Technical Data

---

## 4.2 24 hrs of continuous output

The 24-hour continuous output levels will only be reached when the specified fuel quality is adhered to.

Designation	Unit	Eco-PK 130	Eco-PK 150	Eco-PK 170	Eco-PK 200	Eco-PK 220	Eco-PK 230
24 hrs of continuous output	kWh	2808	3218	3585	4298	4665	4881

## 4.3 Inadmissible fuels

Inadmissible fuels

- Fuel with water content >35%
  - ↳ Formation of condensate
  - ↳ Increased corrosion in the boiler
- Paper, cardboard
- Chip boards, impregnated timber
- Black coal, brown coal or lignite
- Waste
- Plastics

## 5 Boiler room design

Boiler rooms must be designed in accordance with local regulations.

⇒ [See "Design of boiler room" in the installation manual](#)

- Keep the system air inlets clear
- Never store flammable materials in the boiler room
- Design the boiler room to be frost-proof
- Maximum ambient temperature up to 40°C
- Ensure fireproof, level and solid floor and ceiling construction
- In accordance with regulations, have the main heating switch installed by an electrician (depending on building regulations)
- Fire extinguisher

## 6 Design of the fuel storage room

Design your pellet fuel storage room in accordance with local regulations (e.g. EN ISO 20023 or VDI 3464).

⇒ [See "Design of the fuel storage room" in the installation manual](#)

- Only install metal fill pipes, earthed and connected to outside
- Consider noise protection for wall openings
- Protection against moisture, water and dust
- Correctly position impact protection mat and install slant floor

<b>D A N G E R</b>	
	<p><b>Risk of explosion, risk of suffocation</b></p> <p><b>Burns due to explosive burning of dust (pellet dust) in the storage room</b></p> <ul style="list-style-type: none"> <li>• Ensure that the pellet hoses are earthed.</li> <li>• No motors in the storage room.</li> <li>• No other ignition sources (light) in the storage room.</li> <li>• No electrical equipment (switches) in the storage room.</li> <li>• No welding works in a dusty environment.</li> </ul> <p><b>Risk of suffocation from odourless carbon monoxide</b></p> <ul style="list-style-type: none"> <li>• Ventilate sufficiently before entering the storage room.</li> <li>• Keep window and door open while inside.</li> <li>• Position second person outside to supervise.</li> </ul>

# I Technical Data

## 7 Design of heat circuits

Proper design of the heat circuits is essential for optimum boiler operation.

⇒ [Authorised hydraulic schemes: see enclosed hydraulic schemes](#)

Accumulators, pumps and mixers for heat circuits must be designed according to current standards by the commissioning engineer

## 8 Back-end protection unit

If the temperature of the heating-water return is below the value preset in the parameters, hot flow from the boiler is mixed to the return. Use of a back-end protection unit is mandatory when operating the boiler.

⇒ [See "Back-end protection" installation manual](#)

## 9 Flue pipe - chimney connections

Description	Unit	Eco-PK 130	Eco-PK 150	Eco-PK 170	Eco-PK 200	Eco-PK 220	Eco-PK 230
Nominal heating output	kW	130	149	166	199	216	226
Flue gas temperature	°C	150			160		
CO <sub>2</sub>	%	14					
Mass flow rate	kg/sec	0.0731	0.0836	0.0926	0.1105	0.1200	0.1255
Req. delivery pressure	Pa	2					
Flue draft max. limit	Pa	10					
Diameter of flue pipe connection	mm	200			250		

## 10 Electrical supply

⇒ [See enclosed electrical manual](#)

Electrical energy	Characteristics	Unit
Voltage	400	V ± 5 %
Frequency	50	Hz ± 5 %
Back-up fuse	13	A
Power consumption <sup>a</sup>	191-228	W

a. Calculated in accordance with the EN 303-5 testing requirements without the pumps and fuel extraction system





Dimensions in (..) valid for Eco-PK 100-120

- The electrical supply may only be established by a licensed and authorised electrician and must be in accordance with the enclosed electrical manual
- Attach a lockable main power switch outside the boiler room (as per building regulations)
- Max. back-up fuse **13 A** (C type)
- It is absolutely imperative that the intrinsically safe cables are **permanently installed**
  - Use suitable mechanical fixing material
- Establish mains supply **L** and **N** (see electrical manual)
- Connect equipotential bonding conductor
- Use highly flexible cables (e.g. **H05VV-F**)

## Chapter II: Safety regulations

### 1 General safety regulations

#### 1.1 Obligation to instruct, external visitors and children

<b>D A N G E R</b>	
    	<p><b>Danger to life</b></p> <p><b>Risk of death, injuries, damage due to improper use by unauthorised persons</b></p> <ul style="list-style-type: none"> <li>• Observe the safety instructions of the system and in the operation manual.</li> <li>• Read the user manual prior to commissioning.</li> <li>• Only let qualified and trained staff work on the system.</li> <li>• Decide who is responsible for managing the system.</li> <li>• Keep external, unauthorised people away from the system and the storage room.</li> <li>• Do not disclose access codes for the control unit.</li> <li>• Observe the legal minimum age of staff.</li> <li>• Place prohibition sign on boiler room door and fuel storage door.</li> </ul> <p><b>Risk of suffocation from odourless carbon monoxide</b></p> <ul style="list-style-type: none"> <li>• Ventilate sufficiently before entering the storage room.</li> <li>• Keep window and door open while inside.</li> <li>• Position second person outside to supervise.</li> </ul>

Work on the boiler's electrical parts must only be carried out by an electrician and in accordance with the electrical engineering regulations.

Work on hydraulic systems must be carried out only by personnel with specialised knowledge and experience in heating engineering and pipework construction.

#### 1.2 Special measures prior to commissioning by the operator

- Licensing requirements for safe operation and accident prevention regulations must be observed!
- Carry out the required checks prior to commissioning  
⇒ [See "Checks prior to commissioning" on page 14.](#)
- Carry out the required checks before switching the system/boiler on  
⇒ [See "Inspections before starting up the boiler" on page 15.](#)







#### 1.3 Key issuing

<b>D A N G E R</b>	
	<p><b>Risk of injury and/or material damage</b></p> <p><b>Injuries or damage to the system due to unauthorised commissioning</b></p> <ul style="list-style-type: none"> <li>• Prevent unauthorised commissioning</li> <li>• Secure (lock) the system against commissioning and keep the keys safe</li> </ul>

## II Safety regulations

### 2 Remaining risks

The following residual risks must be particularly taken into account when the system is operated properly and in accordance with its intended purpose:

 	<p style="text-align: center;"><b>D A N G E R</b></p> <p><b>Risk of burns, risk of scalding</b></p> <p><b>Burns due to hot surfaces or hot ash</b></p> <ul style="list-style-type: none"><li>• Shut down the system and let it cool down before carrying out any maintenance or servicing work.</li><li>• Do not reach into the system during operation.</li><li>• Wear heat-resistant safety gloves. The ash in the ash container stores heat.</li><li>• Do not empty hot ash into dustbin.</li><li>• Put hot ash in closed, not-flammable vessels only.</li></ul> <p><b>Scalds due to sprinkling, hot water</b></p> <ul style="list-style-type: none"><li>• Check all hoses, lines and connections periodically for leakages, wear and tear or any other damage.</li><li>• Rectify damage immediately.</li><li>• Before performing any maintenance work on the water circulation system, depressurise the system.</li><li>• Check that all valves are in the correct position.</li></ul>
 	<p style="text-align: center;"><b>D A N G E R</b></p> <p><b>Risk of fire, explosion and deflagration</b></p> <p><b>Dust explosion due to electro-static charging in the storage room</b></p> <ul style="list-style-type: none"><li>• Ensure that the pellet hoses are earthed.</li><li>• No motors in the storage room (acc. to country-specific regulations).</li><li>• No other ignition sources (light) in the storage room.</li><li>• No electrical equipment (switches) in the storage room.</li><li>• No welding works in a dusty environment.</li></ul>
 	<p style="text-align: center;"><b>D A N G E R</b></p> <p><b>Risk of fire, explosion and deflagration</b></p> <p><b>Burns from explosive combustion of residual gases (CO) in the combustion chamber</b></p> <ul style="list-style-type: none"><li>• Carefully open the Combustion chamber door slightly first.</li><li>• Keep your body and face away from the Combustion chamber door .</li><li>• Do not open the Combustion chamber door during or immediately after a power failure, as this increases the risk of deflagration.</li><li>• Do not open the Combustion chamber door in heating mode.</li></ul>

	<p style="text-align: center;"><b>D A N G E R</b></p> <p><b>Risk of injury</b></p> <p><b>Risk of crushing and amputation due to moving parts</b></p> <ul style="list-style-type: none"> <li>• Refrain from accessing augers or motors when the boiler is switched on.</li> <li>• Do not work on the system while people are in the danger zone. Secure and lock storage room.</li> <li>• Only clean the augers and remove blockages using suitable tools and when the system is switched off.</li> <li>• Only eliminate cavity formations using rods or shovels.</li> <li>• Wear safety shoes.</li> <li>• Observe the storage room sticker.</li> </ul>
	<p style="text-align: center;"><b>D A N G E R</b></p> <p><b>Danger to life</b></p> <p><b>Electric shock from contact with live terminals</b></p> <ul style="list-style-type: none"> <li>• Observe information signs.</li> <li>• Before starting work, check that no voltage is present using a voltmeter.</li> </ul>
	<p style="text-align: center;"><b>D A N G E R</b></p> <p><b>Risk of poisoning and suffocation</b></p> <p><b>Death, poisoning or suffocation due to flue gas in the boiler room or in the building</b></p> <ul style="list-style-type: none"> <li>• Check system doors and seals for leaks.</li> <li>• Burning treated wood (paints, varnishes, waterproofing) creates toxic ash. Avoid skin and eye contact.</li> </ul>
	<p style="text-align: center;"><b>W A R N I N G</b></p> <p><b>Risk of injury and/or material damage</b></p> <p><b>Injuries and/or damage due to unexpected operating conditions</b></p> <ul style="list-style-type: none"> <li>• Limit switches or motors are not monitored in manual operation. Only run the augers backwards briefly (max. 2 seconds).</li> <li>• Allow qualified and trained staff only to manually operate the system.</li> </ul>

## II Safety regulations

---

### 3 Measures in case of danger

#### 3.1 Fire in the boiler room

- Switch off the main heating switch before fighting any fires
  - ☞ Disconnect the main power supply
- Switch off main power switch and disconnect power supply to boiler room

#### 3.2 After a power outage

Do not open the boiler's doors or reach into it during a power failure.

- ☞ Danger of deflagration
- ☞ Danger of crushing by the augers

After the electrical supply is switched on again, the control starts in **Heat up** mode and monitors the flue gas temperature.

- ☞ If the flue gas temperature rises, the system heats up and regulates the transfer of heat according to the preset parameters

#### 3.3 Leak in heating water system

When the water pressure is too low, not enough heat is transferred from the boiler to the heat circuits, the HWT and the accumulator.

- ☞ Danger of boiler overheating
- Stop heating up the boiler
- Fix leak
- Fill / refill water circulation system
- Check water pressure

#### 3.4 Leaks in the system (escaping flue gas)

- Stop heating up the boiler
- Check the seals of the doors and cleaning covers, and have them replaced

#### 3.5 Auger blockages

Do not touch the blocked augers.

- ☞ Danger of crushing from sudden release of blockage
- Briefly run the blocked auger backwards in manual mode (max. 2 seconds)
  - ☞ Danger of fuel being compressed in the auger
- Only clean the augers and remove blockages using suitable tools and when the main power switch is turned off and locked

## Chapter III: Operation

### 1 Overview of boiler components

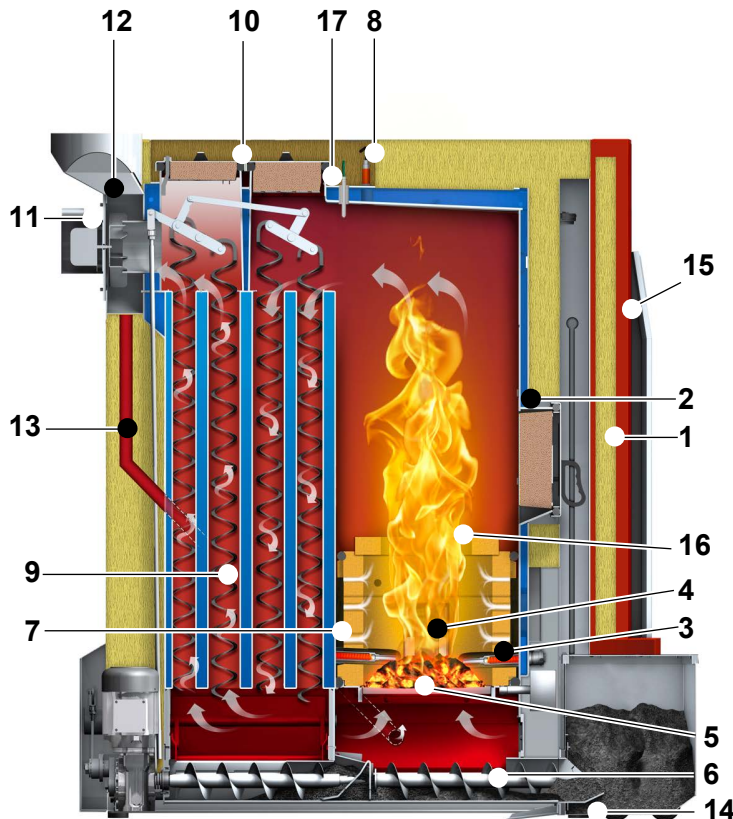

Item	Description
1	Boiler cover door
2	Combustion chamber door
3	Ignition
4	Firebed monitoring
5	Double rotary step grate
6	Ash auger
7	Refractory
8	Lambda sensor
9	Turbulators
10	Cleaning cover
11	Exhaust fan
12	Flue gas sensor
13	Recirculation
14	Ash box (suction system optional)
15	Control unit
16	Flame concentration jet
17	Combustion chamber sensor

The system consists of the combustion chamber and the heat exchanger and controls the combustion air with the exhaust fan and air flaps.

The lambda sensor consistently monitors the flue gases. The integrated sensors monitor the temperatures of the system and the flue gas. The turbulators clean the heat exchanger using a rod. The boiler cleans itself at regular intervals using the de-ash system. The ash extraction auger transports the fly ash, as well as the grate ash into the ash box. Optionally a suction system into a 300 litre ash bin is available for the ash.

Ignition is via two automatic energy-saving ignitions (300 W).

#### 1.1 Function

- Fuel transport from the storage room
- Transport of the fuel into the combustion chamber
- Ignition and combustion of the fuel
- Control of heat transfer to the heating-water system
- Cleaning of the boiler and the ash extraction into the box
- Evacuation of the flue gases

##### 1.1.1 Operating modes

- Automatic mode
- HWS operation
- Manual operation
- Off (frost protection and residual heat use activated)
- Firing off

## 2 Prior to commissioning

	<p style="text-align: center;"><b>D A N G E R</b></p> <p><b>Danger to life and risk of material damage</b>  <b>Death, personal injury and/or damage due to missing, defective or bypassed safety devices or system parts</b></p> <ul style="list-style-type: none"> <li>• Check safety devices and system parts carefully to ensure they are working properly and as intended.</li> <li>• Never modify or bypass safety devices.</li> <li>• Perform repair measures immediately in case of a malfunction or defect.</li> <li>• Place, position and function of all safety devices must be known.</li> </ul>
	<p style="text-align: center;"><b>D A N G E R</b></p> <p><b>Risk of injury</b>  <b>Injury and/or damage due to unexpected operating states</b></p> <ul style="list-style-type: none"> <li>• Make sure that start-up or initial commissioning is performed by Hargassner GmbH or specially trained staff.</li> </ul>
	<p style="text-align: center;"><b>W A R N I N G</b></p> <p><b>Risk of injury and crushing</b>  <b>Danger of crushing from moving system parts</b></p> <ul style="list-style-type: none"> <li>• Make sure that no persons are in the danger zone.</li> <li>• Do not reach into any reachable mechanical parts.</li> <li>• Do not stand on the system.</li> <li>• Make sure that no foreign parts (tools, etc.) remain in the system.</li> </ul>

### 2.1 Checks prior to commissioning

- Safety on-site and plumbing and electrical installations
- Correct assembly of the boiler/system
- Check all necessary components
  - Check tightness, proper function, rotation of all motors, etc.
  - Check correct position of combustion chamber lining

### 2.2 Commissioning

Once the boiler has been installed properly and all the required safety devices have been checked, the boiler can be commissioned in accordance with the commissioning checklist in the inspection book.

	<p style="text-align: center;"><b>N O T E</b></p> <p>The boiler must be commissioned by an engineer with a Hargassner commissioning certificate. The completed commissioning and handover report must be sent back to Hargassner Ges mbH with the commission number within 30 days of commissioning, otherwise the warranty becomes void. A copy remains in the commissioning book on-site.</p>
---	---

## 2.3 Customer instructions

- Explain cleaning and maintenance intervals
- Explain inspections prior to any fuel refill
- Explain how to operate the boiler and resolve issues

## 2.4 Starting the boiler for the first time

The boiler can be started for the first time once commissioned.

- Switch the boiler to manual mode
  - ☞ Use parameter no. 10 to fill the empty combustion chamber in manual mode
    - ☞ Prevents an error due to missing fuel
- Switch the system to **Auto** mode
  - ☞ Boiler starts automatically when hot water is needed

## 2.5 Recirculation setting



- ☞ The default recirculation setting is 100%
- Check the recirculation setting prior to commissioning

## 2.6 Inspections before starting up the boiler

- Check water pressure in boiler, heat, HWT and accumulator circuits
- Pay attention to the display for notifications (error messages and operating status)
- Rectify any errors
- Check and lock the fuel storage room

## 2.7 Filling the fuel storage room

- ☞ Protect fuel against moisture

	W A R N I N G
	<p><b>Fire hazard</b></p> <p><b>Danger of flue gas suctioned out of the system</b></p> <ul style="list-style-type: none"> <li>• Always switch off the system before blowing pellets into the storage room.</li> </ul>

### 3 Control unit

D A N G E R	
	<p><b>Risk of injury</b></p> <p><b>Injury and/or damage to the system due to unexpected operating states</b></p> <ul style="list-style-type: none"> <li>• Only allow trained staff to operate the control unit.</li> <li>• Access to all functions of the control unit is protected by codes. Codes may not be disclosed to third parties.</li> </ul>

#### 3.1 Home view

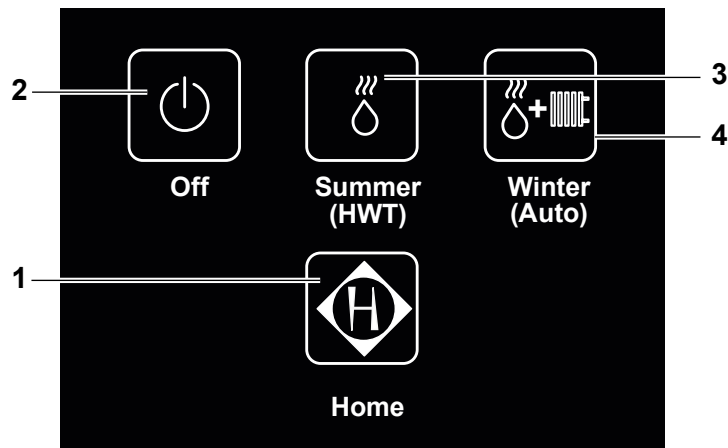









Item	Description	Function
1	Standard menu	Switching from <b>Home</b> to the <b>Standard menu</b> ⇒ See "Standard menu view" on page 18.
2	Operating mode <b>Off</b>	Quick select button for operating mode <b>Off</b>
3	Operating mode <b>Summer</b>	Quick select button for operating mode <b>Summer</b> (HWT mode)
4	Operating mode <b>Winter</b>	Quick select button for operating mode <b>Winter</b> (Automatic)

☞ After the time set in the **No. 02 Display settings** setup parameter has elapsed, the control unit automatically switches to the Home view.

## 3.2 Touchscreen

The control unit is designed as a touchscreen.

☞ It is operated using finger pressure on the display.

- ☐ Scroll through the menu with  
- ☐ To return to the previous menu, press  **Standard**
- ☐ To return to the Standard menu, press  **Standard** (you may have to press 2x)
  - ☞ Possible from every menu
- ☐ Activate the operating mode by pressing the  **Function selection** button
- ☐ Press the field to activate the input field
  - ☞ Values are displayed in **red**
- ☐ Change the active values:  
  - ☞ Values flash **red**
  - ☞ Buttons flash **green**
- ☐ To enter or save any changes, press 
- ☐ You can go straight to the customer parameters by pressing the relevant graphic in the standard menu
  - ☞ Possible with the system, accumulator, HWT, external heat boiler and heat circuit graphics

### 3.3 Standard menu view

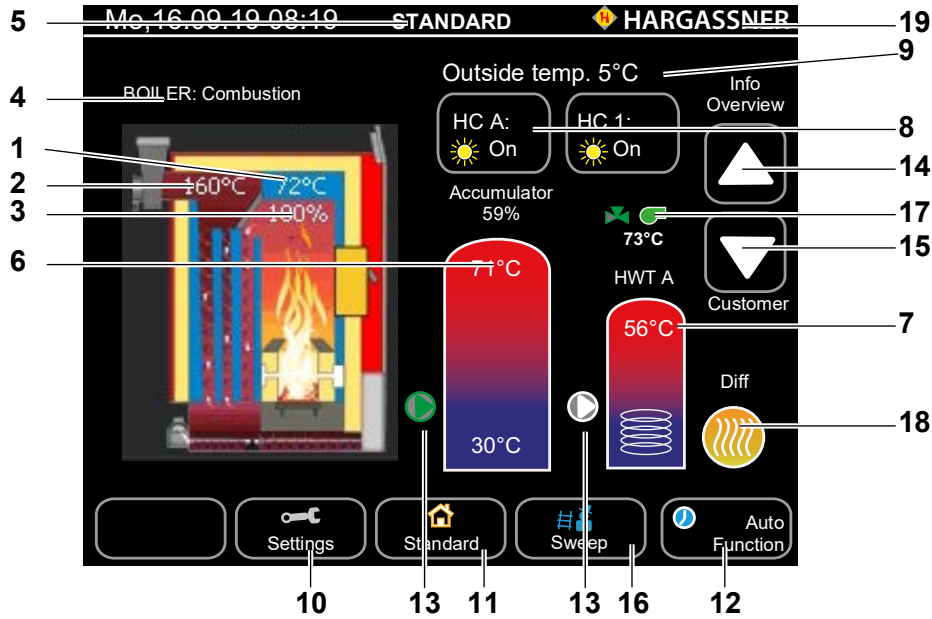

Item	Description	Function
1	Boiler temperature	Displays the current boiler temperature
2	Boiler flue gas temperature	Display of the current flue gas temperature
3	Boiler output	Display of the current boiler temperature
4	Status display of the boiler	⇒ See "System status indicators" on page 20.
5	Status display of the control unit Display of the current menu name	<ul style="list-style-type: none"> <li>• Description of the active menu</li> <li>• Error (flashes red) / notices (yellow)</li> <li>• Current position in menu tree</li> <li>• <b>Locked in x days</b> - dongle error</li> </ul>
6	Temperature display in accumulator tank (if available) Display of accumulator filling volume in [%]	Current accumulator temperatures (top, mid, bottom) of connected accumulator sensors Currently filled heat capacity
7	HWT temperature indicator	Display of the current water temperature in the HWT
8	Status display of heat circuits	<ul style="list-style-type: none"> <li>•  Heat circuits switched off</li> <li>•  Sun - Heat circuits in day mode</li> <li>•  Moon - Heat circuits in reduced mode</li> <li>•  Frost - Heat circuits in frost protection mode</li> </ul>
9	Display of outside temperature	Outside temperature measured with outdoor sensor
10	Settings	Takes you to the customer, commissioning engineer and service settings and to the control unit setup menu.
11	Standard	Displays the standard menu. You can switch directly to the Standard menu from any menu. After 10 minutes of no activity, the display automatically switches back to the <b>Standard</b> display menu
12	Function	Select boiler operating mode. ⇒ See "Operating modes" on page 19.
13	Pump	Pump operating mode green: Pump is running. White: Pump has stopped
14	Info	<ul style="list-style-type: none"> <li>•  Switching to the Info menu</li> </ul>
15	Customer	<ul style="list-style-type: none"> <li>•  Switching to the customer settings</li> </ul>
16	Test mode (chimney sweep)	By pressing the test mode button, a special boiler status programme is started to measure the flue gas consistency
17	External heat boiler	Status display of external heat boiler (if available) green: released. white: locked
18	Differential control	Pressing the symbol will take you to the differential control info page
19	Hargassner logo	Press on the logo to display the boiler data

## 4 Operating modes

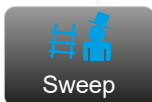
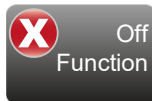

- **Automatic (Auto):** The standard mode in which the heating system is operated according to the preset temperatures and on/off times.
- **Hot water (HWT):** The heating system is only used to ensure the hot water supply, not to heat any floor heating system or radiators.
  - ☞ Heat circuits are not controlled (except for frost protection function)
  - ☞ Pumps **Off** and mixers **Closed**
- **Switch off (Off):** The heating system is switched off - with the exception of the frost protection function. The touchscreen continues to show all current information.
  - ☞ Heat circuits are not controlled (except for frost protection function)
  - ☞ Pumps **Off** and mixers **Closed**
- **Manual operation:** Allows various actions to be carried out manually, such as manual activation of individual pumps and mixers. Also shows additional information and values.  
The Standard menu view is kept in the Automatic, Hot water and OFF operating modes.
- **Test mode button:** The button for the chimney sweep to manually switch the system **On** or **Off** during emission tests.  
The following options are available:
  - ☞ **Full load:** If an accumulator is connected, press this button to have the control unit automatically change to full load measurement.
  - ☞ **Empty accumulator:** Press this button to switch off all the boiler's programmed control functions. The boiler operates at full load, assumes very low outdoor temperatures and tries to transport as much as possible heat into the heating system. All regulating devices like thermostatic valves and automatic control valves have to be opened manually to ensure that the required amount of heat is transferred. This function ends automatically after 2 hours. If the test mode button is pressed and no accumulator is connected, the control unit offers two options: **full-load measurement** and **partial-load measurement**. All programmed control functions are switched off in the partial load measurement function. The boiler controls up to full load. After 15 minutes of full load, output is reduced to 50% (partial load). After 5 minutes of partial load, the message "**Start test mode measuring**" will appear on the display.
- **Firing OFF:** Button for switching firing off. Firing can be switched off immediately or at a preset time.
  - ☞ Control of the heating circuits with the pumps and mixer continues; only firing is switched off.

## 5 System status indicators

The control unit uses the temperatures and flue gas values to detect the status of the boiler.

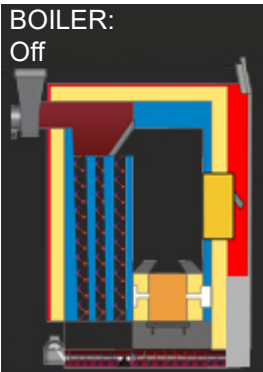

### Off

The boiler switches off if there is no demand from the heat circuits or HWTs or if the accumulator takes care of the demand.

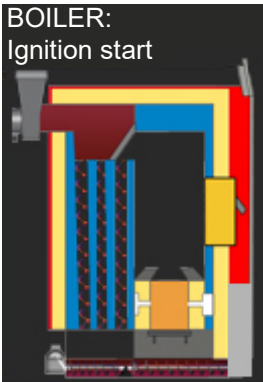

### Ignition start

Fuel is transported into the combustion chamber and the boiler monitors if autonomous ignition occurs due to residual embers.

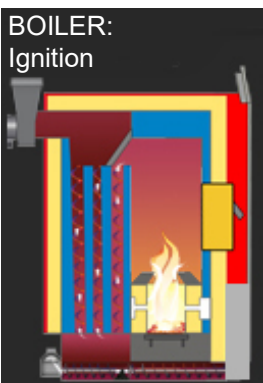

### Ignition

The electric ignition starts and the fuel is ignited.

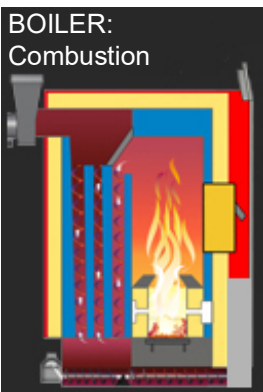

### Combustion

The boiler controls exhaust fan output (air volume) according to the heat demand and required boiler temperature, and the optimum fuel amount according to the lambda sensor signal.

☞ Combustion output range from 30-100%

### Burnout

The system controls the burnout depending on the O<sub>2</sub> content and the set minimum and maximum burnout time (service settings)

☞ Primary air to 100%

☞ Exhaust fan to 100%



### Slumber mode

If the heat demand drops below the minimum boiler output, the system switches to slumber mode.

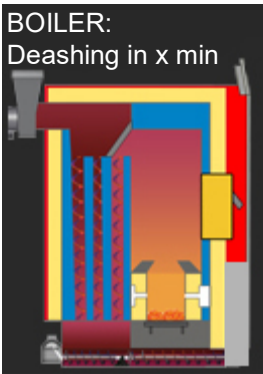

### Deashing in x min

When the maximum combustion time is reached, the combustion chamber is "burnt out".

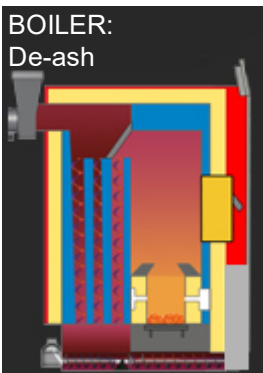

### De-ash

- **Partial de-ash:** The ash grate makes a full rotation until it stops at its original position. The turbulators clean the heat exchanger. The ash falls onto the ash auger and is transported and compressed in the ash box. The system returns to the required state afterwards
- **Complete de-ash:** All grates are opened completely and the turbulators clean the heat exchanger. The ash falls onto the ash auger and is transported and compressed in the ash box. The system returns to the required state afterwards

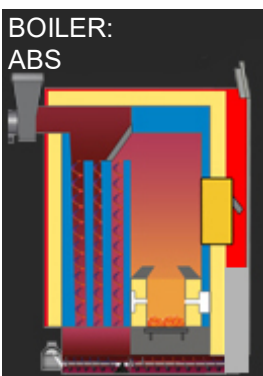





### ABS Automatic blockage protection

Exhaust fan, ash auger, cleaning device and ash auger system are started (duration 10 seconds). The touch screen displays **Caution, ABP function is starting.**

- ☞ During the **ABP** state, do not switch off the system, do not open the system's doors or reach into the system.

## 6 Info menu

- Press  in the **Standard** menu
- Use arrows to move within the menu    
Target: Adjustment value / target value  
Actual: Current value (position)
- In the respective Info menu, press the  symbol to go straight to the settings

### 6.1 Overview

Mo.16.09.22 08:19	HARGASSNER
FE cover	Closed
Ash box	OK
Heat circuit A	Reduction
Heat circuit 1	Reduction
Heat circuit 2	Reduction
Heat circuit 3	Reduction
HWT A	Off
HWT 1	Off
Accumulator	Off

Shows an overview of heat circuits, HWTs and any other components of the individual heating system.

### 6.2 District line pump

Mo.16.09.22 08:19	HARGASSNER
District line pump 1 Pump	 On

If a heat circuit has a district line, the status of the district line pump is shown on this page (green = **On**, white = **Off**).

### 6.3 External heat circuit

Mo.16.09.22 08:19	HARGASSNER
External heat circuit 1	On
Pump	 On
Target temp.	60°C

If an external heat circuit is available, a corresponding info page is shown at this point.

### 6.4 Heat circuits

Shows the status of the heat circuits. One heat circuit is displayed per page. If there are several heat circuits, several info pages are available in the menu. If the mixer pump is running, this is indicated as text and by a green arrow icon.

- Use the symbol next to the heat circuit **(1)** to access the configuration pages
- You can also press the heat circuit button in the standard view directly to go to the first heat circuit page
-  If a FR25, FR35 or FR40 is used, it is shown in an additional line
- Select the heating mode using the heating mode symbol **(2)**

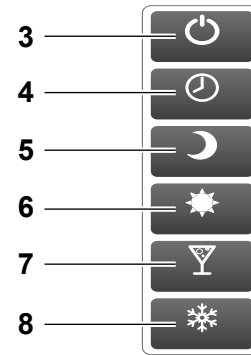
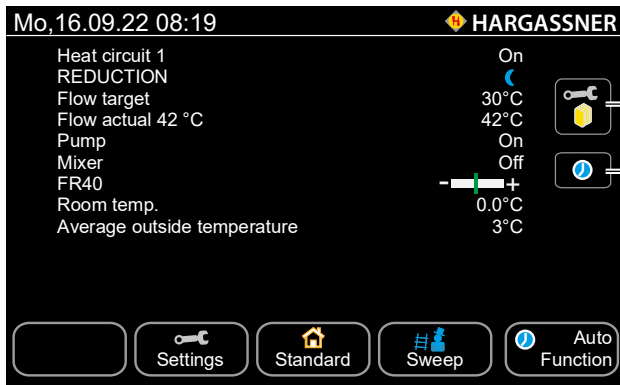

Item	Description	Function
1	Heat circuit configuration	The button next to the corresponding heat circuit is used to jump to the setting options in the configuration pages
2	Heating mode configuration	The button is used to enter the pop-up menu for selecting the heating mode
3	Off	Heat circuit is switched off (except for frost protection function)
4	Automatic	Heat circuit runs according to the timer programme's settings
5	Continuous reduction	The room temperature is continuously being reduced to the preset room temperature (reduction mode)
6	Continuous heating	The room temperature is continuously being heated to the preset room temperature (heating mode)
7	1x heating	The heat circuit heats the room temperature to the target value (heating mode) and switches back to the automatic timer programme during the next heating cycle (or after 24 hours at the latest)
8	1x reduction	The heat circuit reduces the room temperature to the target value (reduction mode) and switches back to the automatic timer programme during the next heating cycle (or after 24 hours at the latest)

## 6.5 Hot water tank

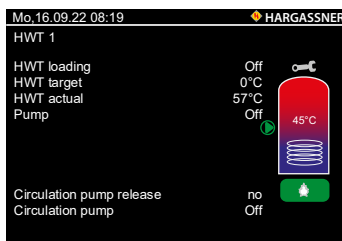

Info page about the HWT status

- HWT loading
- Target temperature
- Actual temperature
- HWT fill level display
- Pump status

If more HWT are parametrised, more info pages are also available. The circular arrow symbol next to the HWT graphic shows if the HWT pump is running or not (green: on, white: off).

☞ Use the HWT icon to access the HWT setting options in the configuration pages

- **One-time charge** button

☞ Press the button to recharge the HWT once to its target temperature

## 6.6 Back-end protection unit

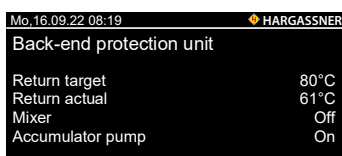

Info page about the current status of the back-end protection

- Return target
- Return actual
- Mixer
- Accumulator pump

## 6.7 Differential control

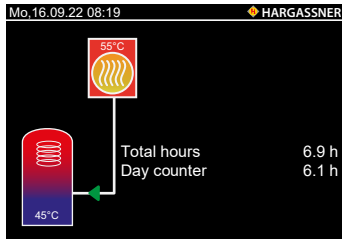

Info page about the current status of differential control

- Differential control operating hours
- Total / day
- Current heat source temperature
- Current temperature at differential sensor (S2)

## 6.8 Boiler

	TARGET	ACTUAL
Boiler temp.	95°C	72°C
Exhaust fan	80%	80%
Delivery rate		75%
Primary air	0%	0%
Tertiary air	100%	100%
O2	7.0%	6.0%
Combustion chamber		160°C
Negative pressure		93Pa
Firebed	60°C	70°C
Stoker grate		0°
Ash grate		0°
Ignition		Off

Info page about the current set / actual values of the boiler

- Current operating status of the boiler
- Water temperature in the boiler
- Exhaust fan speed in % of maximum speed
- Currently necessary fuel rate
- Primary air flap position in % of maximum opening
- Tertiary air flap position in % of maximum opening
- Flue gas oxygen value in % - measured on the lambda sensor
- Current temperature in the combustion chamber (post combustion chamber)
- Negative pressure in pascals measured with the negative pressure sensor
- Firebed sensor position (tongue)
- Ignition active / not active
- Stoker grate 1 / 2 position
- Ash grate / intermediate grate position

## 6.9 Accumulator

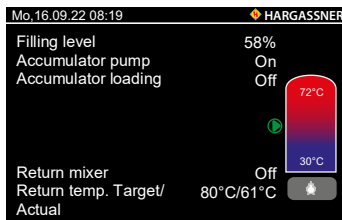

Info page about the current actual values of the accumulator

- Accumulator fill level display
- ☞ Filling level: 80% = red
- ☞ Filling level: 30% = blue
- ☞ Fill level between 30% and 80% = blue / red
- Return temperature target / actual = Temperature of boiler return
- **One-time charge** button 
- ☞ Press the button to recharge the HWT once to its target temperature

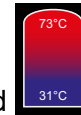

## 6.10 External heat

External heat operation	Off
External heat temperature	0°C
External heat valve	Off

Info page about the current values of the external heat

- External heat operation indicator (**On / Off**)
- Current external heat sensor temperature
- External heat valve indicator (**On / Off**)
- External heat pump (**On / Off**)

## 6.11 Consumption

Consumption display	
Pellet consumption	
Total	122.71 kg

Info page about the current overall consumption

- Display only available if the pellet consumption display is activated in the service settings

## 6.12 Trend

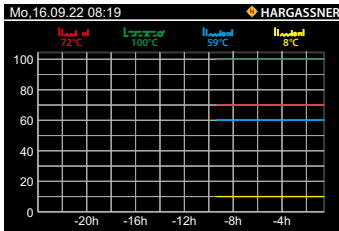

Diagram of recording from the last 24 hours

- Boiler temperature
  - HWT temperature
  - Power
  - Accumulator filling level
- ☞ The timeline can be set for activated service settings

## 6.13 Electricity

Mo,16.09.22 08:19 HARGASSNER	
Stoker	0.0A (max.0.8A)
Extraction	0.0A (max.1.7A)
Ash auger	0.0A (max.2.5A)
Stoker grate	
Ash grate	

List of current electricity consumption

- Stoker
- Extraction
- Ash auger
- Stoker grate
- Ash grate

## 6.14 Counter

Mo,16.09.22 08:19 HARGASSNER	
Control unit operating hours	9h
Heating operating hours	9h
Ignition operating hours	0.0h
Exhaust fan operating hours	9h
Stoker operating hours	7.34h
Extraction operating hours	5.8h
Number of minor de-ash cycles	0
Number of major de-ash cycles	0

List of current operating hours

Mo,16.09.22 08:19 HARGASSNER	
Runtime of CMB since de-ash	180 min
De-ash at the earliest after	60 min
De-ash at the latest after	180 min
Release de-ash	00:00-24:00 H
No. of de-ash cycles since last major de-ash	0
Number of stoker grate blockages	0
Number of blockages of ash grate	0

## 6.15 Serial number

Mo,16.09.22 08:19 HARGASSNER	
Boiler type	Eco-PK
Commission no.	1
Software version	V16.0l
Control unit serial number	575242
Firmware version I / O	
Serial number I / O	
IP address	0.0.0.0
Boiler status ID-Card	OK
System code	3035B7B0
SW update	9 November 2018

List of the relevant system data

## 6.16 Error

Mo,16.09.22 08:19 HARGASSNER	
0305	Wrong boiler ID-Card Mo 19-11-2018 09:19
0307	Exhaust fan error Mo 19-11-2018 09:19
0309	Negative pressure too low Mo 19-11-2018 09:19

Overview of current errors

- ☞ Once the fault is rectified, the error message is no longer shown

## 7 Manual operation

### WARNING



#### Risk of injury and/or material damage

#### Injuries and/or damage due to unexpected operating conditions

- When working in manual mode, limit switches and motors are not automatically monitored. Only run the augers backwards briefly (2 seconds maximum).
- Allow qualified and trained staff only to manually operate the system



**Manual mode** is used to:

- Check all electrical functions
- Manually operate or check the drives after a malfunction
- To activate the function, press or press and hold the button
- To deactivate the function, press again or release the button
- To activate continuous operation (2 minutes maximum), press the button twice when the service settings are activated.

Only the selected function is activated. All other functions are inactive.

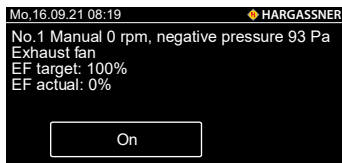

No. 1 Function check of exhaust fan

- Speed reached: approx. 3,500 rpm

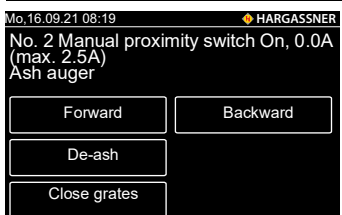

No. 2 Function and rotation check of ash extraction motor

- Forward
- Backward
- De-ash
- Close grates
- Press Backward button only **briefly**

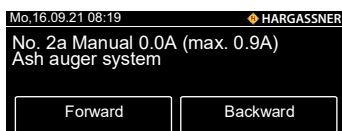

No. 2a Function check on the ash transportation system

- Forward
- Backward

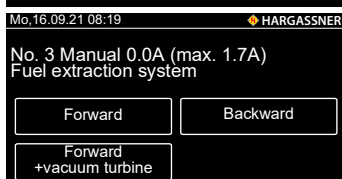

No. 3 Function and rotation check of fuel extraction motor

- Manual forward and backward of the motor to clear any blockages
- Manual forward + vacuum turbine
- Press Backward button only **briefly**
- For double fuel extraction system, the additional parameter **No. 3a** is shown



No. 5 Function and rotation check of stoker auger motor

- Manual forward and backward to fill the stoker auger
- Press Backward button only **briefly**
- For double rotary valve, the additional display No. 5a is shown

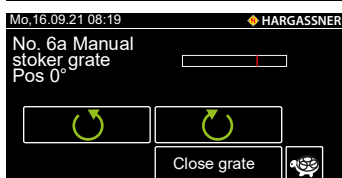

No. 6a Function and rotation check on stoker grate motor

- Manual forward or backward of the motor
- Close grate

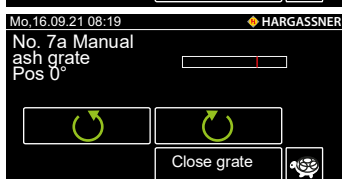

No. 7a Function and rotation check on ash grate motor

- Manual forward or backward of the motor
- Close grate

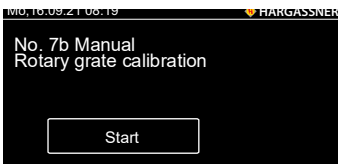

### No. 7b Calibration of all rotary grates

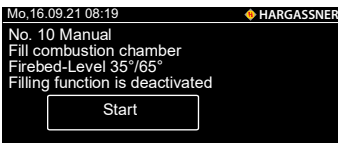

### No. 10 Fill combustion chamber

- Rotary grates are moved into position
- Combustion chamber is filled with fuel
- ☞ Prevents an error due to too long absence of fuel

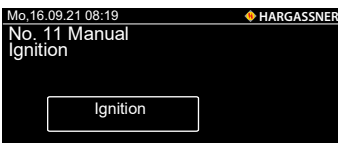

### No. 11 Function check of ignition

- ☞ After a maximum of 1 minute, the coil should be hot
- ☞ After 3 minutes the ignition coil switches off



### No. 12 Function and position check of the primary air flap (Target / Actual)

- ☞ 100% - **Open**; 0% - **Closed**
- Position at both extremes **0%** and **100%**
  - ☞ Press **Open** or **Close** and monitor the actual value as it changes

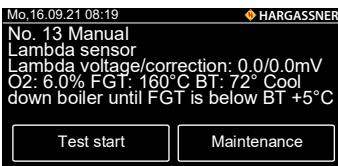

### No. 13 Test lambda sensor (duration approx. 5 minutes)

- Press Test start
  - ☞ After the preset period of time, a correction value must be displayed
  - ☞ If the value is not reached, the message "Lambda sensor defective" will be displayed
  - ☞ Note: After the test, tighten lambda sensor sufficiently and reinsert the flue gas sensor
- ☞ Calibrate the lambda sensor with service settings activated



### No. 14 Function test of the ash vacuum turbine

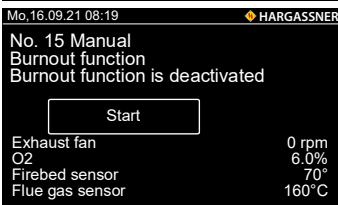

### No. 15 Automatic burnout function in case of error

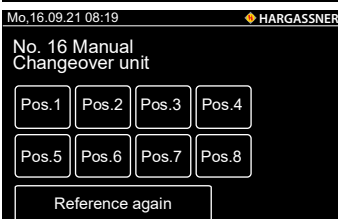

### No. 16 a / b Function check of the changeover unit AUP or AUE

- ☞ Pos. = Display of the current position

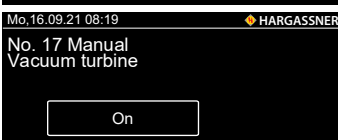

### No. 17 Function check of the pellet vacuum turbine

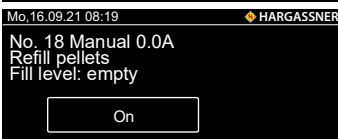

### No. 18 Filling the day hopper

- ☞ Must be filled at restart
- ☞ The fill level indicator switches the turbine off automatically
- ☞ Caution: Short post-run period of the vacuum turbine

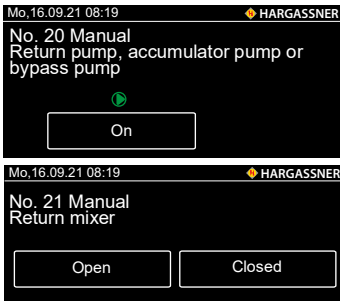

No. 20 Function check or manual operation of the parametrised pump



No. 21 Function and rotation check of return mixer

- The mixer is **Closed** when the boiler circuit is closed
  - The mixer is **Open** when the return is open
- ☞ During operation, the return temperature increases when the mixer **Closes** and the return temperature decreases when the mixer **Opens**

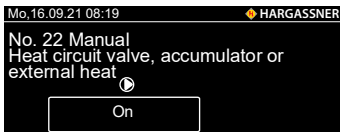
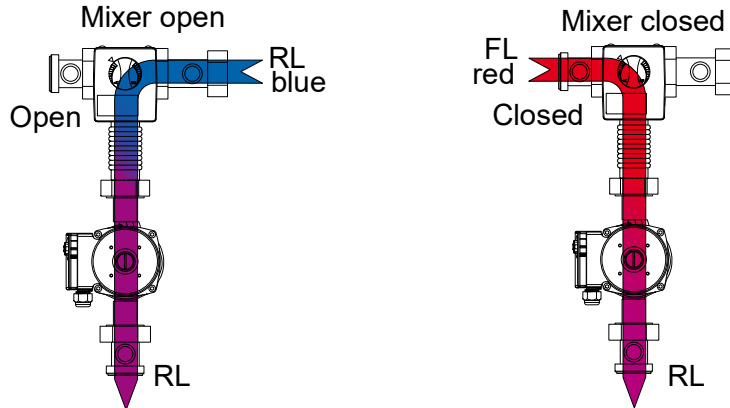

No. 22 Function check of the heat circuit valve, accumulator or external heat valve

☞ As per parametrisation (accumulator or external heating)

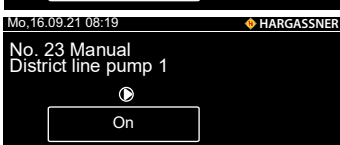

No. 23 Function check or manual operation of district line pump 1

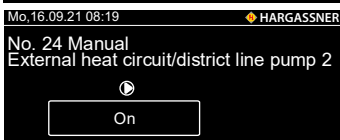

No. 24 Function check or manual operation of external heat circuit pump or district line pump 2

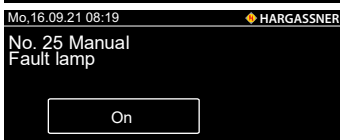

No. 25 Function check or manual operation of the fault lamp

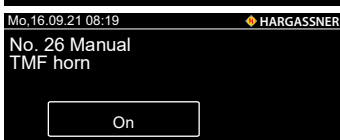

No. 26 Function check or manual operation of the signal horn TMF

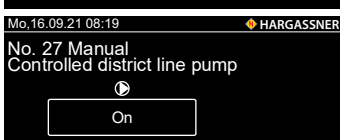

No. 27 Function check or manual operation of the pump for the controlled district line

☞ Only when **CDL** is connected

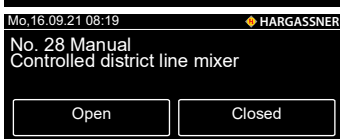

No. 28 Function and rotation check of the mixer for the controlled district line

☞ Only when **CDL** is connected

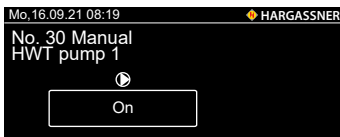

No. 30 Function check or manual operation of HWT loading pump 1

- ☞ Only with connected **HKM 0**
- ☞ No. 40, 50 and 60 for HWT pumps A, 2 and 3 only when **HC A, HKM 1** and **HKM 2** are connected

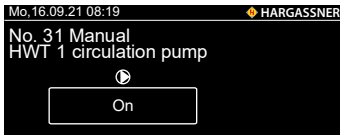

No. 31 Function check or manual operation of circulation pump HWT 1

- ☞ Only with connected **HKM 0**
- ☞ No. 41, 51 and 61 for HWT circulation pump A, 2 and 3 only possible when **HC A, HKM 1** and **HKM 2** are connected

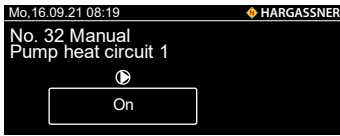

No. 32 Function check or manual operation of heat circuit pump 1

No. 34 Function check or manual operation of heat circuit pump 2

- ☞ Only with connected **HKM 0**
- ☞ No. 42, 52 and 62 for heat circuit pumps A, 3 and 5 only possible when **HC A, HKM 1** and **HKM 2** are connected

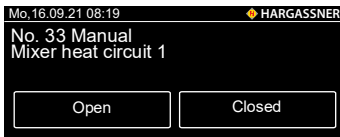

No. 33 Function and rotation check of mixer of heat circuit 1

No. 35 Function and rotation check of mixer of heat circuit 2

- ☞ Only with connected **HKM 0**
- ☞ No. 43, 53 and 63 for mixer heat circuits A, 3 and 5 only when **HC A, HKM 1** and **HKM 2** are connected

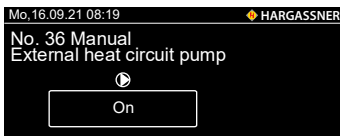

No. 36 Function check or manual operation of the external heat circuit pump 1

- ☞ Only with connected **HKM 0**
- ☞ No. 56 and 66 for external heat circ. pump 2 and 3 only when **HKM 1** and **HKM 2** are connected

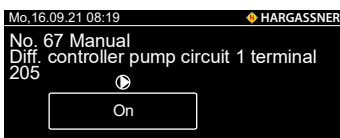

No. 67 Function check or manual operation of the differential control pumps

- ☞ Only when a differential controller is connected

No. 67b for pump heat source

No. 67c for valve / return mixer

No. 68 for differential controller 2

No. 71 - 74 Display of the current sensor values

- ☞ According to parametrised heating system

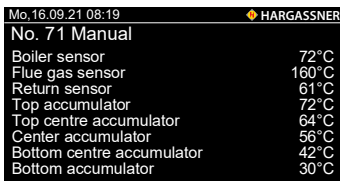

Display of the current sensor values

- ☞ According to parametrised heating system

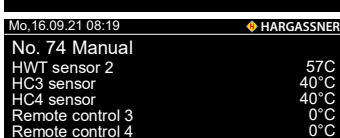
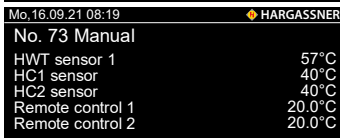
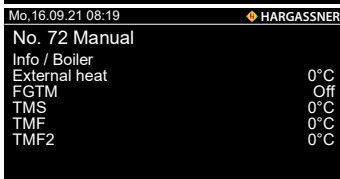

- ☞ Depending on the parametrised heating system, other parameters can follow

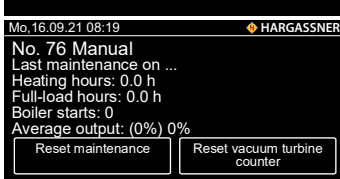

## 8 Settings menu

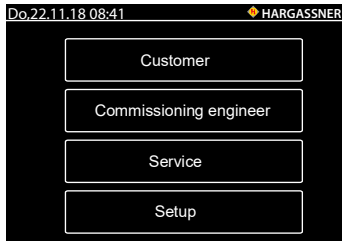

Press the **Set** button in the standard display to access the Settings menu.

- Customer
- Commissioning engineer
- Service
- Setup

### 8.1 Customer

This button will take you to the configuration screens, which can also be accessed from the standard menu.

⇒ See "Customer settings" on page 33.

### 8.2 Commissioning engineer

Permits advanced system settings and is only available to commissioning engineer and Hargassner service personnel. The individual parameter settings depend on the respective heating system configuration.

Code: 33

⇒ See "Commissioning settings" on page 39.

### 8.3 Service

Allows more parameter details to be changed and is only available to service personnel. The individual parameter settings depend on the respective heating system configuration.

**Note:** Commissioning engineer and service settings are protected by a PIN code. Only service personnel can change them, as the parameters may impair the functionality of the heating system if poorly selected.

### 8.4 Setup

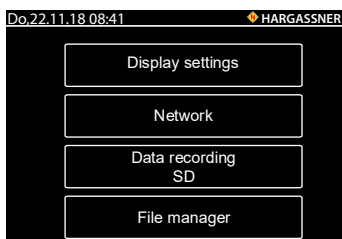

The following setting options are available:

- Display settings
- Network settings
- Data recording (SD)
- File manager

#### 8.4.1 Display settings

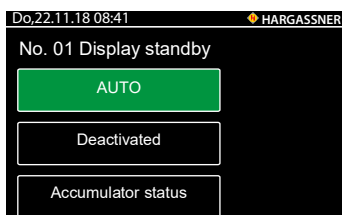

No. 01 Display standby

☞ Activates or deactivates standby mode

☞ Accumulator status shows the current accumulator loading in standby mode

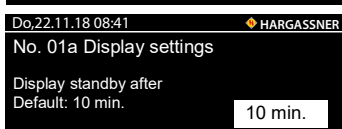

No. 01a Display settings

☞ Display switches to standby mode after preset time

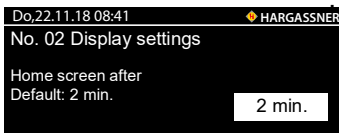

No. 02 Display settings

- ☞ Display switches to Home view after a set time
- ☞ Setting 0 deactivates this function

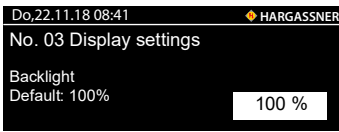

No. 03 Display settings

- ☞ Set display backlight (10% - 100%)

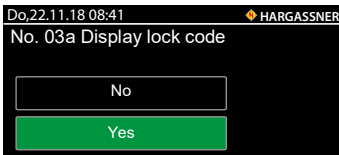

No. 03a Display lock code

- ☞ Select whether you want to enter a code to lock the display

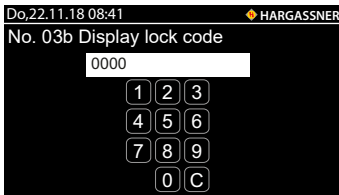

No. 03b Display lock code

- ☞ Enter 4-digit lock code

8.4.2 Network settings

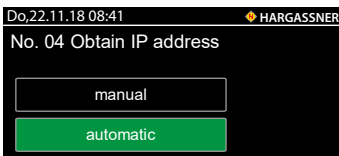

No. 04 Obtain IP address

- ☞ Select whether you want to generate the IP address manually or automatically



No. 05 IP address

- ☞ Manual entry of the IP address

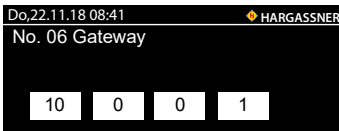

No. 06 Gateway

- ☞ Manual entry of the gateway

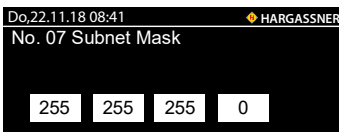

No. 07 Subnet Mask

- ☞ Manual entry of the Subnet Mask

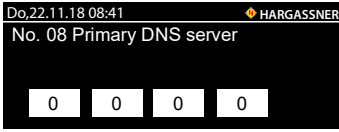

No. 08 Primary DNS server

- ☞ Manual entry of the Primary DNS server

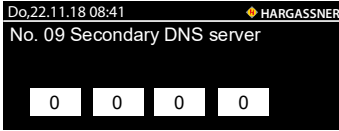

No. 09 Secondary DNS server

- ☞ Manual entry of the secondary DNS server

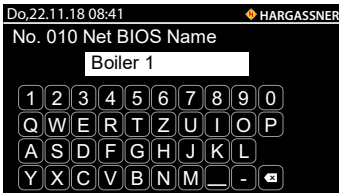

No. 010 Display of the name of device

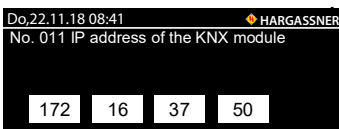

No. 011 IP address of the KNX module

#### 8.4.3 Data recording (SD)

Additional saving of current boiler data on the SD card.

To finish the protocol, press **Stop SD logging**

#### 8.4.4 File manager

Used to import and export parameter information, text files, languages, backups and error lists.

## 9 Customer settings

- In the standard menu, press the **Set** button and then press the **Customer** button.
- Select the desired setting value with the arrow button.
- Select the values by touching the fields highlighted in white
  - ☞ The font colour of the parameters changes to **red**
- Press the **+** and **-** buttons to set your desired values, the display flashes
  - ☞ Press and hold the **+** and **-** buttons for to adjust the values quickly
- Confirm the set value with the green checkmark

### 9.1 HWT control

☞ The day clock is set to weekly clock and the number of blocks is changed in the commissioning engineer settings (parameter D9 + D10)

#### 9.1.1 Day timer

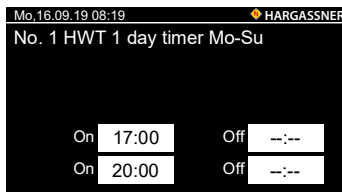

No. 1 HWT 1 day timer Mo-Su

- Setting the loading times of the HWT using the day timer

#### 9.1.2 Week timer

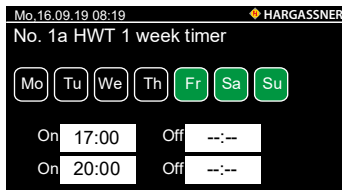

No. 1a HWT 1 week timer

- Setting the loading times of the boiler using the week timer
- ☞ Selected day = green

#### 9.1.3 Target temperature

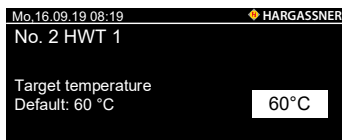

No. 2 HWT 1 - Setting the HWT target temperature

☞ HWT loading is done only during the set **loading times**

#### 9.1.4 Circulation pump

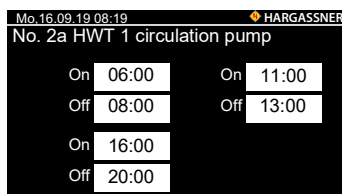

No. 2a HWT 1 circulation pump

- Setting the switching times of the circulation pump (if available)

#### HWT temperatures according to factory settings

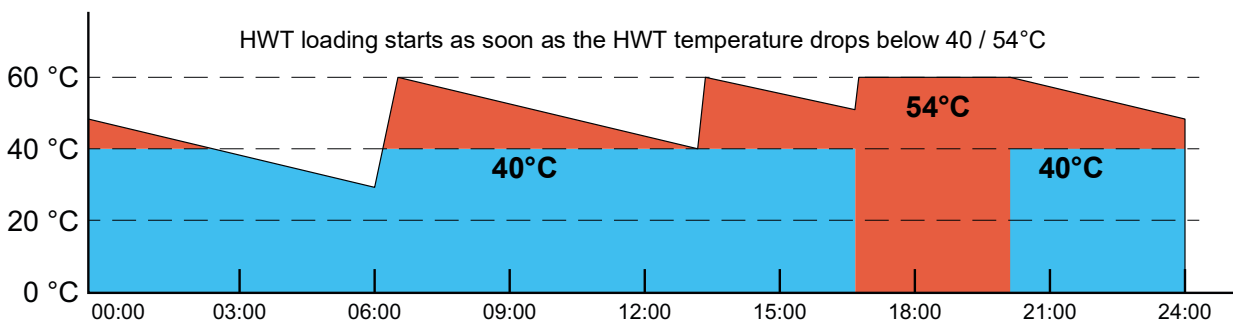

## 9.2 Control of heat circuits

- ☞ The day clock is set to weekly clock and the number of blocks is changed in the commissioning engineer settings (parameter D9 + D10)

### 9.2.1 Day timer

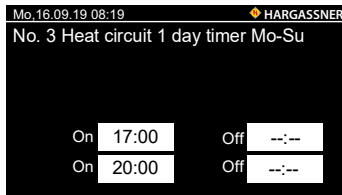

No. 3 heat circuit 1 day timer Mo-Su

- Setting the heating times using timer
- ☞ The selected times are the same for all weekdays

### 9.2.2 Week timer

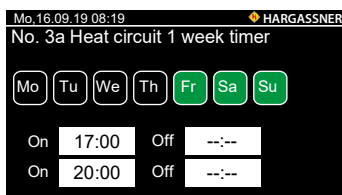

No. 3a Heat circuit 1 week timer

- Setting the heating times using the week timer

### 9.2.3 Room temperature

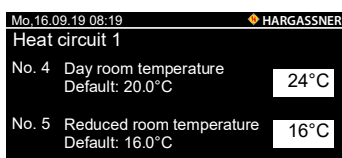

No. 4 Day room temperature / No. 5 Reduced room temperature

- Set the desired room temperature
- ☞ Range of the day room temp.: 14°C - 26°C
- ☞ Range of the setback/reduced room temperature: 8°C - 24°C

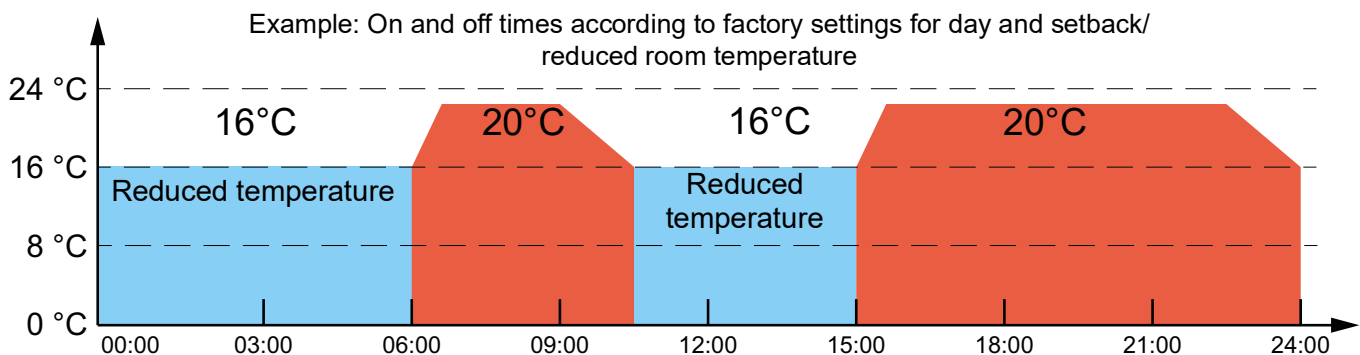

### 9.2.4 Outside temperature shut-down

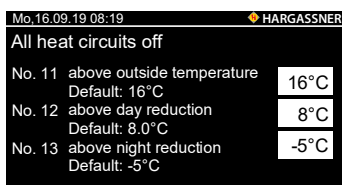

- Setting the temperatures for the outside temperature shut-down

☞ Three possible thresholds depending on the heating programme and time

#### No. 11 All heat circuits off via outside temperature

- ☞ If the average outside temperature exceeds the set value, the heat circuits will be switched off (summer shut-down).

#### No. 12 All heat circuits off during day reduction

- ☞ If the average outside temperature exceeds the set value in day reduction mode, the heat circuits will be switched off.

#### No. 13 All heat circuits off during night reduction

- ☞ If the average outside temperature exceeds the set value during the night reduction time, the heat circuits will be switched off.

Example: Heat curve according to factory settings for outside temperature shut-down

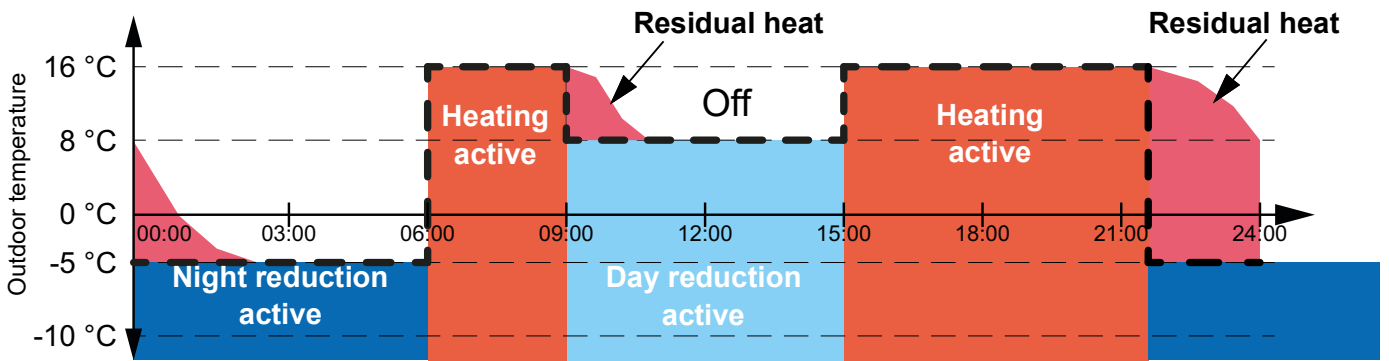

### 9.3 General settings

#### 9.3.1 Holiday mode

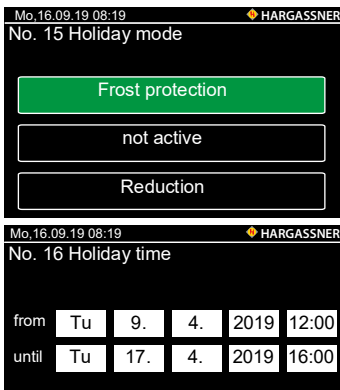

No. 15 Holiday mode

- Setting the holiday mode function
- ☞ Only activated if parameter D11 is set to **Yes** in the commissioning engineer settings

No. 16 Holiday time

- Setting the holiday time during which holiday mode is activated

#### 9.3.2 Starting de-ash

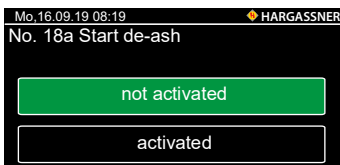

No. 18 Ash suction

- ☞ Only activated if parameter D50 is set to **Available** in the commissioning engineer settings
- Press the **Yes** button to start the de-ash and cleaning process

#### 9.3.3 Date/time

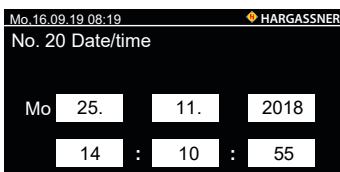

No. 20 Date/time

- ☞ Setting the date and time

#### 9.3.4 Firing Off

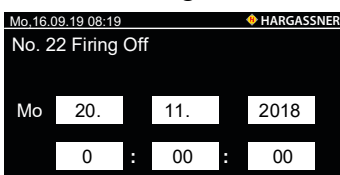

No. 22 Firing Off

- ☞ Setting the date and time for when firing is to be switched off (e.g. when the chimney sweep is expected)

### 9.3.5 Consumption display

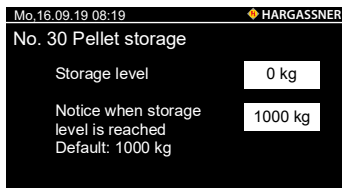

No. 30 Pellet storage

☞ Deviations of up to 20% possible

## 9.4 Parameter list of customer settings

### 9.4.1 Extension module 0

Menu	Description	Default
1	HWT 1 day timer Mo-Su	ON 17:00 OFF 17:30
1a-g	HWT 1 weekly Mo/Tu/We/Th/Fr/Sa/Su	ON 17:00 OFF 17:30
2	HWT 1 target temperature	60°C
2a	Circulation pump HWT 1	ON 06:00 11:00 16:00 OFF 08:00 13:00 20:00
3	Heat circuit 1 day timer Mo-Su	ON 06:00 15:00 OFF 09:00 22:00
3a-g	Heat circuit 1 week timer Mo/Tu/We/Th/Fr/Sa/Su	ON 06:00 15:00 OFF 09:00 22:00
4	Heat circuit 1 day room temperature	20.0°C
5	Heat circuit 1 reduced room temperature	16.0°C
6	Heat circuit 2 day timer Mo-Su	ON 06:00 15:00 OFF 09:00 22:00
6a-g	Heat circuit 2 week timer Mo/Tu/We/Th/Fr/Sa/Su	ON 06:00 15:00 OFF 09:00 22:00
7	Heat circuit 2 day room temperature	20.0°C
8	Heat circuit 2 reduced room temperature	16.0°C
9	Automatically fill and suction times	ON 08:00 00:00 OFF 18:00 00:00

### 9.4.2 Heat circuit board HC A

Menu	Description	Default
HP1	HWT A day timer Mo-Su	ON 17:00 OFF 17:30
HP 1a-g	HWT A week timer Mo/Tu/We/Th/Fr/Sa/Su	ON 17:00 OFF 17:30
HP 2	HWT A target temperature	60°C
HP 2a	HWT A circulation pump	ON 06:00 11:00 OFF 08:00 13:00
HP 3	Heat circuit A day timer Mo-Su	ON 06:00 15:00 OFF 09:00 22:00
HP 3a-g	Heat circuit A week timer Mo/Tu/We/Th/Fr/Sa/Su	ON 06:00 15:00 OFF 09:00 22:00
HP 4	Heat circuit A day room temperature	20.0°C
HP 5	Heat circuit A reduced room temperature	16.0°C

### 9.4.3 Extension module HKM 1

Menu	Description	Default
H 1	HWT 2 day timer Mo-Su	ON 17:00 OFF 17:30
H 1a-g	HWT 2 weekly Mo/Tu/We/Th/Fr/Sa/Su	ON 17:00 OFF 17:30

Menu	Description	Default
H 2	HWT 2 target temperature	60°C
H 2a	HWT 2 circulation pump	ON 06:00 11:00 OFF 08:00 13:00
H 3	Heat circuit 3 day timer Mo-Su	ON 06:00 15:00 OFF 09:00 22:00
H 3a-g	Heat circuit 3 week timer Mo/Tu/We/Th/Fr/Sa/Su	ON 17:00 OFF 20:00
H 4	Heat circuit 3 day room temperature	20°
H 5	Heat circuit 3 reduced room temperature	16°
H 6	Heat circuit 4 day timer Mo-Su	ON 06:00 15:00 OFF 22:00 09:00
H 6a-g	Heat circuit 4 week timer Mo/Tu/We/Th/Fr/Sa/Su	ON 17:00 OFF 20:00
H 7	Heat circuit 4 day room temperature	20°
H 8	Heat circuit 4 reduced room temperature	16°

#### 9.4.4 Extension module HKM 2

Menu	Description	Default
H 11	HWT 3 day timer Mo-Su	ON 17:00 OFF 17:30
H 11a-g	HWT 3 weekly Mo/Tu/We/Th/Fr/Sa/Su	ON 17:00 OFF 17:30
H 2	HWT 3 target temperature	60°C
H 12a	HWT 3 circulation pump	ON 06:00 11:00 OFF 08:00 13:00
H13	Heat circuit 5 day timer Mo-Su	ON 06:00 15:00 OFF 09:00 22:00
H 13a-g	Heat circuit 5 week timer Mo/Tu/We/Th/Fr/Sa/Su	ON 17:00 OFF 20:00
H 14	Heat circuit 5 day room temperature	20°C
H 15	Heat circuit 5 reduced room temperature	16.0°C
H 16	Heat circuit 6 day timer Mo-Su	ON 06:00 15:00 OFF 09:00 22:00
H 16a-g	Heat circuit 6 week timer Mo/Tu/We/Th/Fr/Sa/Su	ON 06:00 15:00 OFF 22:00 09:00
H 17	Heat circuit 6 day room temperature	20.0°C
H 18	Heat circuit 6 reduced room temperature	16.0°C

#### 9.4.5 Heat circuit board HC B

Menu	Description	Default
H21	HWT B day timer Mo-Su	ON 17:00 OFF 17:30
H21 a-g	HWT B week timer Mo/Tu/We/Th/Fr/Sa/Su	ON 17:00 OFF 17:30
H22	HWT B target temperature	60°C
H22a	Circulation pump HWT B	ON 06:00 11:00 OFF 08:00 13:00
H23	Heat circuit B day timer Mo-Su	ON 06:00 15:00 OFF 09:00 22:00
H23a-g	Heat circuit B week timer Mo/Tu/We/Th/Fr/Sa/Su	ON 06:00 15:00 OFF 09:00 22:00
H24	Heat circuit B day room temperature	20.0°C
H25	Heat circuit B reduced room temperature	16.0°C





If **Outside temperature shut-down separated** is chosen (commissioning engineer parameter no. D12), different temperatures can be set for each heat circuit

Menu	Description	Default
11	Heating off at outside temperature over	6°
11a-i	Heat circuit 1-B and ext. HC off above outside temperature	6°
12	All heat circuits off during day reduction	8°
12a-h	Heat circuit 1 - A off during day reduction	8°
3	All heat circuits off during night reduction	-5°
13a-h	Heat circuit 1 - A off during night reduction	-5°
15	Holiday mode	not active
15a-h	Holiday mode heat circuit 1-B	not active
16	Holiday time	from...
16a-h	Heat circuit 1-B holiday time	from...
17	Holiday time	until...
17a-h	Heat circuit 1-B holiday time	until...
18	Ash suction	not active
18a	De-ash start	No
19	Fuel	Pellets
20	Date/time	
21	Release of remote maintenance	not released
21a	Automatic deactivation of release	1 h
22	Firing off	from... - until...
30	Pellet storage	1000 kg

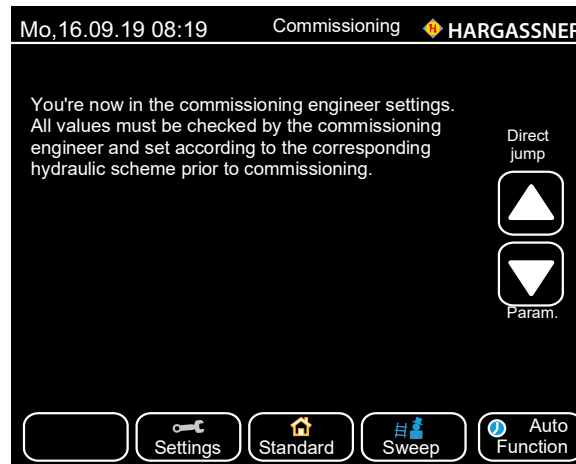
## 10 Commissioning settings

- In the standard menu, press the **Setup** button and then press the **Commissioning engineer** button
- Release by entering the code: 33



- Use the arrow key to select the desired setting values
  -  Takes you straight to the parameter groups
  -  Selects all parameters
- Select the values by touching the fields highlighted in white
  -  The font colour of the parameters changes to red
- Press the + and - buttons to set your desired values - the display flashes
  -  Press and hold the + and - buttons for to adjust the values quickly
- Confirm the set value with the green checkmark

### 10.1 Parametrising the heat circuits and HWT

#### Heat circuit module 0 (HKM0):

- Heat circuit 1 (No. A1 - No. A10)
- Heat circuit 2 (No. A11 - No. A20)
- HWT 1 (No. B1 - No. B9b)

#### Heat circuit module 1 (HKM1):

- Heat circuit 3 (No. A21 - No. A30)
- Heat circuit 4 (No. A31 - No. A40)
- HWT 2 (No. B11 - No. B19b)

#### Heat circuit module 2 (HKM2):

- Heat circuit 5 (No. A41 - No. A50)
- Heat circuit 6 (No. A51 - No. A60)
- HWT 3 (No. B21 - No. B29b)

#### Heat circuit board A (HC A)

- Heat circuit A (No. A61 - No. A70)
- HWT A (No. B31 - No. B39b)

#### Heat circuit board B (HC B)

- Heat circuit B (No. A71 - No. A80)
- HWT B (No. B41 - No. B49b)

-  The parameters of the heat circuits, HWTs, extension modules and the heat circuit board are only displayed when hardware is connected

## 10.2 Parameter A - heat circuits

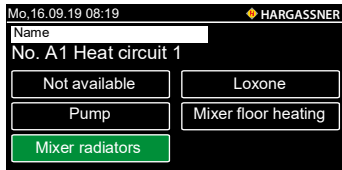

No. A1 and A11 Heat circuit **1** and **2** when extension module **0** is used  
 No. A21 and A31 Heat circuit **3** and **4** when extension module **1** is used  
 No. A41 and A51 Heat circuit **5** and **6** when extension module **2** is used  
 No. A61 Heat circuit **A** when using the heat circuit module **A**  
 No. A71 Heat circuit **B** when using the heat circuit module **B**

5 options:

- Heat circuit not available
- Heat circuit with pump
- Heat circuit with pump and mixer motor for radiator heat circuit
- Heat circuit control by Loxone/Modbus
  - ☞ Parameter A10 emergency operation target temperature if a Loxone connection error occurs
- Heat circuit with pump and mixer motor for floor heat circuits
- ☞ If No. A1 is set to **not available**, then No. A2 to No. A6 are not displayed
- Press **Name** to name each heat circuit separately, (e.g. living room)

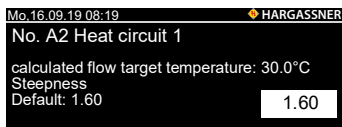

No. A2, A12, A22, A32, A42, A52, A62 and A72 Steepness Heat circuit **1 - B**  
 No. A2a, A12a, A22a, A32a, A42a, A52a, A62a and A72a Steepness FLH Heat circuit **1 - B**

Describes the relationship between flow and outside temperatures (see heating curve)

- Range: 0.2 - 3.5
- Recommended settings:
  - Floor heating: 0.3 - 1.0
  - Radiator heating: 1.2 - 2.0
  - Convector heating: 1.5 - 2.0
- ☞ Change in small steps only and for a longer period

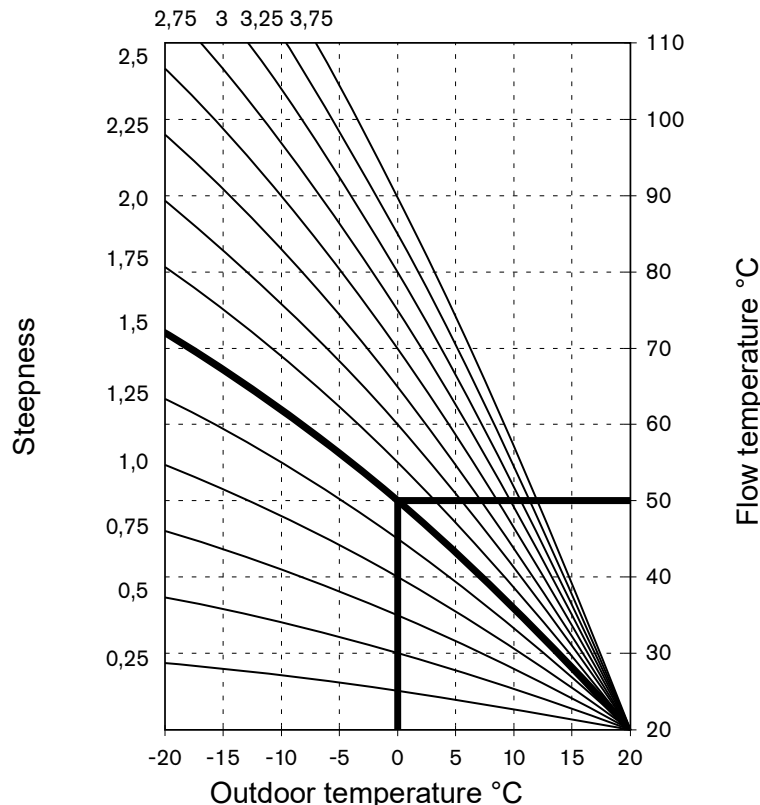

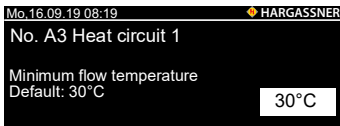

No. A3, A3a, A13, A13a, A23, A23a, A33, A33a, A43, A43a, A53, A53a, A63, A63a, A73 and A73a Minimum limit of the flow temperature for the heat circuit 1 - B

- ☞ This flow temperature won't be underrun in heating or reduction mode
- ☞ Range: 1 - 80 °C

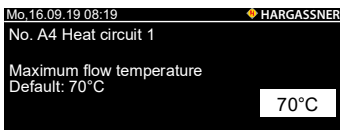

No. A4, A4a, A14, A14a, A24, A24a, A34, A34a, A44, A44a, A54, A54a, A64, A64a, A74 and A74a Maximum limit of the flow temperature for the heat circuit 1 - B

- ☞ This flow temperature won't be overrun in heating or reduction mode
- ☞ **Floor heating:** Integrate an additional electromechanical thermostat which interrupts the power supply to the relevant heat circuit pump

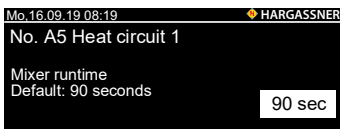

No. A5, A15, A25, A35, A45, A55, A65 and A75 Used to enter the actual mixer runtime for heat circuit 1 - B

- ☞ For the actual mixer runtime, see the type plate
- ☞ Duration from closed to open condition
- ☞ Range: 10 - 300 Sec.

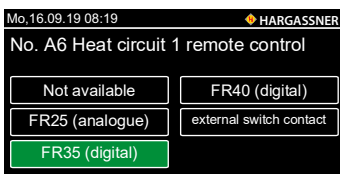

No. A6, A16, A26, A36, A46, A56, A66 and A76 Heat circuit 1 - B remote control 5 options:

- Not available
- Heat circuit with analogue remote control FR25
- Heat circuit with digital remote control FR35
- Heat circuit with digital remote control FR40
- External switch contact

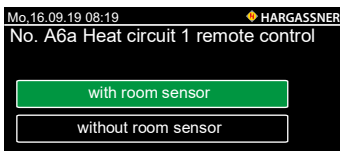

No. A6a / b / c, A16a / b / c, A16a / b / c, A26a / b / c, A36a / b / c, A46a / b / c, A56a / b / c, A66a / b / c and A76a / b / c Heat circuit 1 - B remote control

- The remote control can be installed with or without a room sensor
- Heat circuit with analogue remote control **FR25 without room sensor**
    - No automatic adjustment of the room temperature
    - Wire FR25 at **terminals 1 and 3**
  - Heat circuit with analogue remote control **FR25 without room sensor**
    - Automatic adjustment of the room temperature
    - Wire FR25 at **terminals 1 and 2**

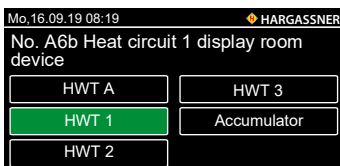

- Heat circuit with digital remote control **FR35 or FR40**
- If **FR35** is set, parameters **A6b, A16b, A26b, A36b, A46b, A56b, A66b** and **A76b** will appear

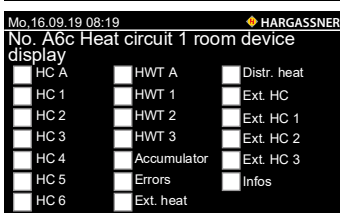

- If **FR40** is set, detail parameters **A6c, A16c, A26c, A36c, A46c, A56c, A66c** and **A76c** will appear

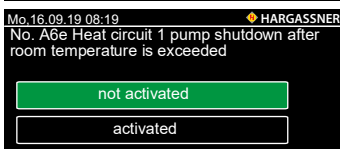

No. A6e, A16e, A26e, A36e, A46e, A56e, A66e and A76e Heat circuit 1 - B pump shutdown after the room temperature is exceeded

- **Not activated:** Standard heat circuit control
- **Activated:** If the room temperature (set temperature) is exceeded by the set value (No. M6 service parameter), the heat circuit pump switches **Off** and the mixer is **Closed**
  - ☞ The pump and mixer will come **On** again when the room temperature drops below the set room temperature by the preset value (service parameter M6a).

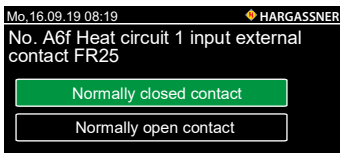

No. 6f, 16f, 26f, 36f, 46f, 56f, 66f and 76f Heat circuit **1 - B** input external contact FR25  
 ☞ Used to specify whether the external contact FR25 is a normally closed contact or a normally open contact

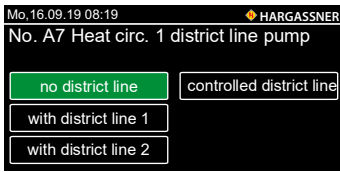

No. A7, A17, A27, A37, A47, A57, A67 and A77 Used to enable the district line pump when heat circuit pump **1 - B** are running  
 ☞ Used to specify whether the district line pump is enabled at the same time as the heat circuit pump **1 - B**

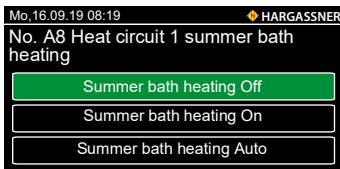

No. A8, A18, A28, A38, A48, A58, A68 and A78 Activation of the summer bath heating for the respective heat circuit  
 ☞ Heat circuit will be switched on (depending on timer settings) if accumulator is on temperature  
 ☞ Is only activated in menu **HWT**  
 ☞ If **On** is selected, parameters **A8a - A8c, A18a - A18c, A28a - A28c, A38a - A38c, A48a - A48c, A58a - A58c, A68a - A68c** and **A78a - A78c** will appear

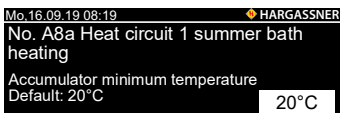

No. A8a, A18a, A28a, A38a, A48a, A58a, A68a and A78a Used to enter the accumulator minimum temperature for heat circuits **1 - B**

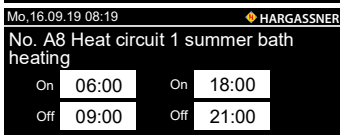

No. A8b, A18b, A28b, A38b, A48b, A58b, A68b and A78b Used to enter the switch-on and switch-off times for heat circuits **1 - B**

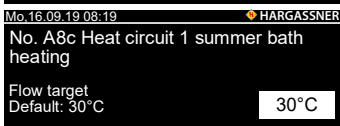

No. A8c, A18c, A28c, A38c, A48c, A58c, A68c and A78c Used to enter the flow target temperatures for heat circuits **1 - B**

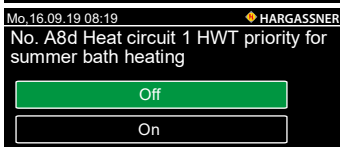

No. A8d, A18d, A28d, A38d, A48d, A58d, A68d and A78d Heat circuits **1 - B** HWT priority for summer bath heating  
 ☞ Used to specify whether HWT priority operation is activated for heat circuits **1 - B** during summer bath heating

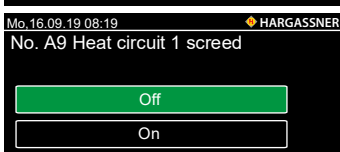

No. A9, A19, A29, A39, A49, A59, A69 and A79 Used to activate the screed dry-out programme for heat circuits **1 - B**  
 ☞ If **On** is selected, parameters **A100-A103** appear

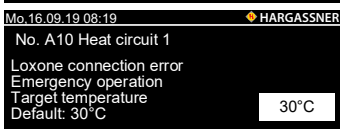

No. A10, A20, A30, A40, A50, A60, A70 and A80 Heat circuits **1 - B** emergency operation Target temperature  
 ☞ Used to specify the temperature to be supplied to heat circuits **1 - B** if the connection to the Loxone server is interrupted

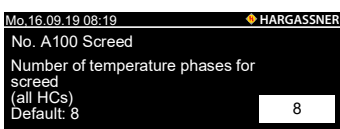

No. A100 Screed temperature phases  
 ☞ Specifies the number of phases used to increase the temperature for the screed heating process

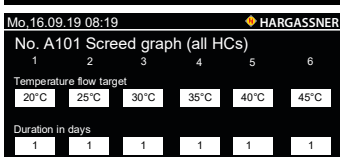

No. A101a Screed graph  
 ☞ The target temperature and holding period can be specified for each phase



### No. A103 Screed hysteresis

☞ If the flow temperature drops below the screed heating target temperature by this value, the timer for the holding period will be stopped and won't resume until the target value has been reached again

## 10.3 Parameter B - HWT

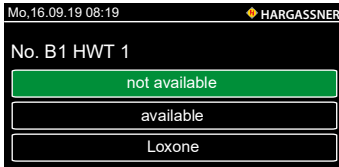

• No. B1, B11, B21, B31 and B41 HWTs 1 - B (heat circuit modules **0 - 2** and heat circuit boards **A - B**) set to **available**

☞ Control of HWTs 1 - B

• HWTs **1 - B** (heat circuit modules **0 - 2** and heat circuit boards **A - B**) set to **Loxone**

☞ HWTs **1 - B** are controlled by the Loxone controller

• Parameter no. B1, B11, B21, B31 or B41 set to **Not available**

☞ If no. B1, B11, B21, B31 or B41 is set to **Not available**, no. B2 - no. B6, no. B12 - no. B16, no. B22 - no. B26, no. B32 - no. B36 and no. B42 - no. B46 are not displayed

Press on **Name** to name each HWT separately

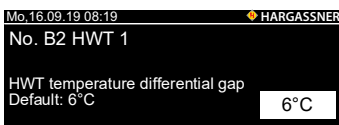

No. B2, B12, B22, B32 and B42 HWTs **1 - B** differential gap

☞ Value at which the HWT is switched on below the set minimum temperature

☞ Range: 1 - 40 °C

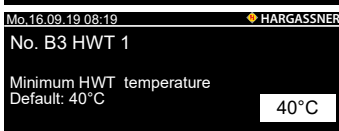

No. B3, B13, B23, B33 and B43 Minimum limit for HWT temperature

☞ If the HWT temperature drops below the preset value, HWT loading starts within the set time (installer setting no. B90) regardless of the HWT time programme (customer setting no. 1)

• Range: 1 - 80 °C



No. B4, B14, B24, B34 and B44 Used to activate the Legionella protection programme

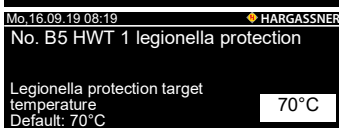

No. B5, B15, B25, B35 and B45 HWT target temperature for Legionella protection

☞ Temperatures of 70°C or above for more than 3 minutes will kill all legionella in the HWT

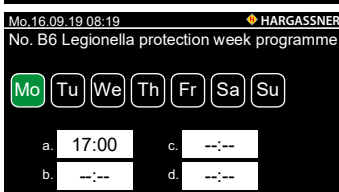

No. B6, B16, B26, B36 and B46 Legionella protection week programme

☞ Green = active

☞ Start legionella protection programme during HWT loading only

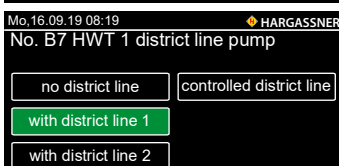

No. B7, B17, B27, B37 and B47 HWTs **1 - B** district line pump

☞ Activate the district line pump when HWT pumps **1 - B** are running

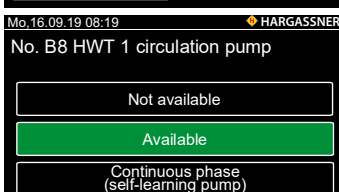

No. B8, B18, B28, B38 and B48 HWTs **1 - B** circulation pump

☞ The circulation pump can be set for each HWT parametrised on the controller

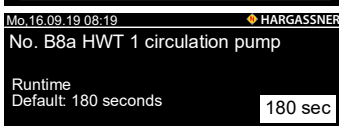

No. B8a, B18a, B28a, B38a and B48a Runtime circulation pump HWT

☞ The runtime depends on the length of the heating pipes and on the heat loss (insulation) in the line

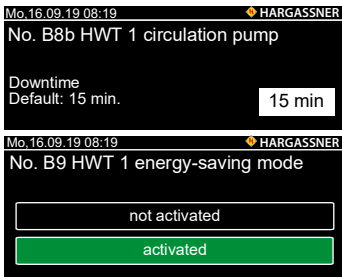

No. B8b, B18b, B28b, B38b and B48b Downtime circulation pump HWT

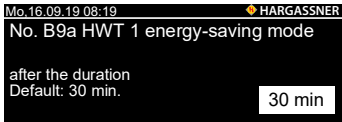

No. B9, B19, B29, B39 and B49 Energy-saving mode

- **Not activated:** The HWT is loaded in accordance with the settings in the customer parameters
- **Activated:** The HWT is loaded regardless of the loading times if the following criteria are met for the set length of time (**No. B9a**) before setback/reduction:
  - HWT has nearly reached its minimum temperature
  - Outside temperature is higher than the temperature for day reduction
  - Boiler is in lower partial-load operation (minimum output + 10%)

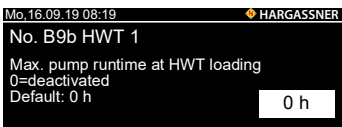

No. B9a, B19a, B29a, B39a and B49a Switch-on time energy-saving mode

- ☞ The HWT is loaded when the following criteria have been met for 30 minutes **before** reduction:
  - Outside temperature above 16 °C (customer setting no. 5)
  - HWT temperature below 50 °C (installer setting no. B3 (40 °C) + 10 °C)
  - Boiler heat output below 60% (service setting no. K1 50% + 10%)

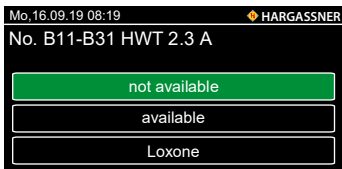

No. B9b, B19b, B29b, B39b and B49b Maximum pump runtime when HWT is loading

- ☞ Default: 0 h (=deactivated)

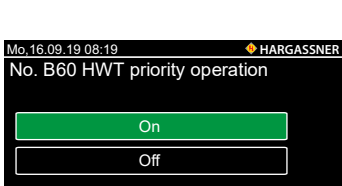

No. B11-B49: Additional HWTs

- B11 - B19: When using a heat circuit module **1**
- B21 - B29: When using a heat circuit module **2**
- B31 - B39: When using a heat circuit board **A**
- B41 - B49: When using a heat circuit board **B**

- ☞ Setting options: See commissioning engineer settings **B1 - B9**

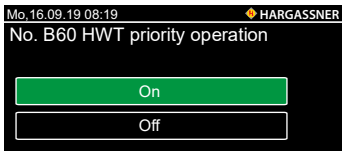

No. B60 HWT priority operation for quick HWT loading

- ☞ For heat circuits with pumps, the heat circuit pumps are switched off throughout HTW priority operation. No heat is transferred from the boiler to the heat circuits
- ☞ The heat circuit flow temperatures for heat circuits with mixers and pumps are reduced throughout priority operation

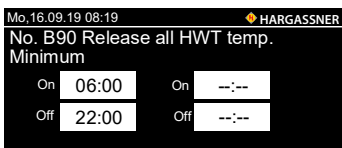

No. B90 HWT loading outside the loading times

- ☞ When the HWT temperature drops below the minimum HWT temperature (commissioning engineer setting **B3**)

No. B100-B117a Freshwater station 1-4

- ⇒ [See the fresh-water station FWS operation manual](#)

## 10.4 Parameter C - accumulator



No. C1a Back-end protection

- Return mixer with district line pump 1
- Return mixer with return pump (hydraulic separator)

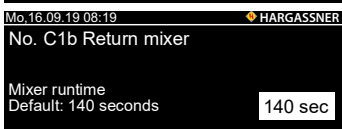

No. C1b Mixer runtime

- ☞ Specifying the actual mixer runtime
- ☞ Range: 10 - 300 sec.

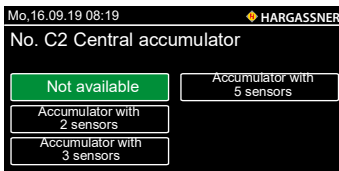

#### No. C2 Central accumulator

- Not available
- Accumulator with 2 sensors
  - ☞ For a hydraulic scheme with loading and unloading control
- Accumulator with 3 or 5 sensors
  - ☞ For an accumulator diagram with loading (partial-load operation) and unloading control

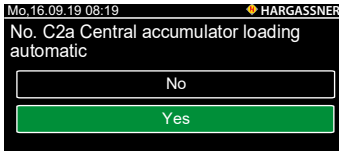

#### No. C2a Central accumulator loading automatic

- ☞ Specifying whether the accumulator should be loaded automatically

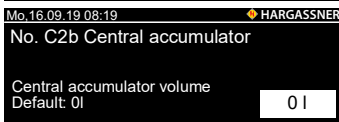

#### No. C2b Central accumulator volume

- ☞ Setting the accumulator volume in litres

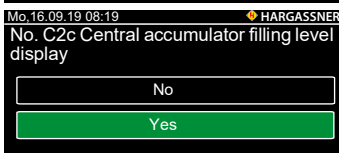

#### No. C2c Central accumulator filling level display

- ☞ Specifying whether the accumulator fill level should be displayed

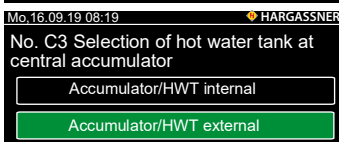

#### No. C3 Selection of hot water tank at central accumulator

- Accumulator/HWT internal
  - ☞ Accumulator tank with HWT integrated (domestic hot water coil or external tap water heat exchanger)
- Accumulator / HWT external (external HWT)
  - ☞ For on-site differential control between accumulator and HWT, set to **accumulator / HWT internal**

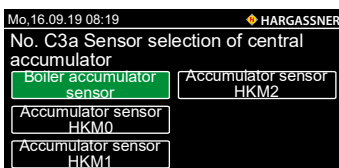

#### No. C3a Sensor selection of central accumulator

- Set where the sensors are connected

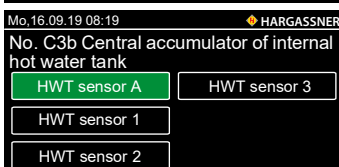

#### No. C3b Central accumulator of internal hot water tank

- ☞ Only for **Accumulator / HWT internal** commissioning engineer setting C3

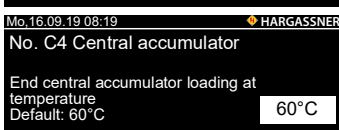

#### No. C4 End central accumulator loading at temperature

- ☞ Only displayed when commissioning engineer setting **C2** is set with **2, 3 or 5 sensors** and when **No** is selected for **C2a**
- ☞ If heat is requested, the accumulator is loaded to its target temperature **C4** = 60°C (bottom accumulator sensor)

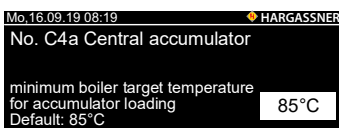

#### No. C4a Central accumulator minimum boiler target temperature for accumulator loading

- ☞ Presetting the boiler target temperature for accumulator loading
- ☞ Only displayed when commissioning engineer setting **C2** is set with **2, 3 or 5 sensors**

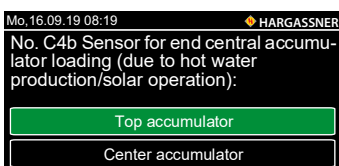

#### No. C4b Sensor for end central accumulator loading

- ☞ Only displayed when commissioning engineer setting **C2** is set with **2, 3 or 5 sensors**

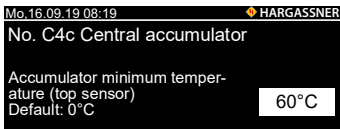

No. C4c Central accumulator minimum temperature  
Lower accumulator limit temperature  
☞ When the accumulator temp is below the set value (accumulator sensor top), accumulator loading starts  
☞ C4c must be at least 10°C lower than C4a

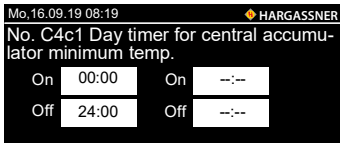

No. C4c1 Day timer for central accumulator minimum temp.  
☞ Defines the period in which the measured temperature from parameter C4c is monitored

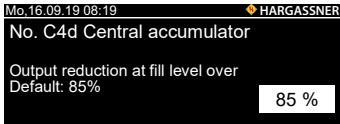

No. C4d Central accumulator output reduction  
☞ When the preset accumulator filling level is reached, the system's output is reduced

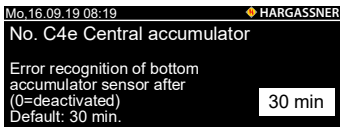

No. C4e Central accumulator error recognition  
☞ A notice is issued when the mixer has been completely open for the preset time and the temperature at the bottom accumulator sensor is 11 °C below that of the return sensor

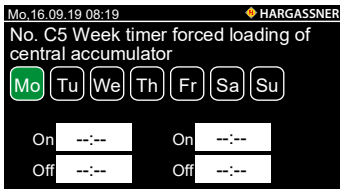

No. C5 Week timer forced loading of central accumulator  
☞ Setting the time for accumulator forced loading  
☞ Displays only if parameter C2 is set to **AT with 2 sensors** or **AT with 3 sensors**  
☞ Accumulator forced loading at the set time and activated set temperature  
☞ E.g. for peak loads in the morning (e.g. 04:00 - 10:00)

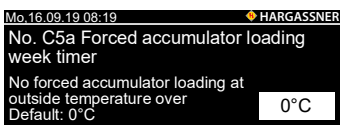

No. C5a Forced accumulator loading week timer  
☞ No accumulator forced loading when the set outside temperature is exceeded

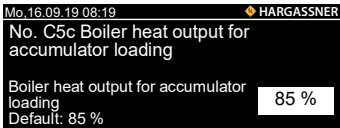

No. C5c Boiler heat output for accumulator loading  
☞ When TSBT reaches the temperature of the highest demand + increase, the boiler reduces the output to the set value

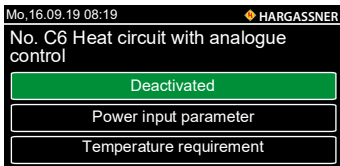

No. C6 External heat circuit with analogue control  
☞ Setting whether the external heat circuit is controlled in an analogue way  
• Deactivated  
• Power input parameter  
• Temperature requirement

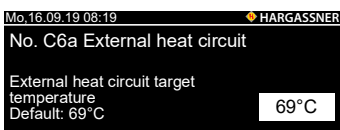

No. C6a External heat circuit  
☞ Adjusting the boiler set temperature for an activated external heat circuit  
☞ If the value is changed and parameter C7 is set to **external pump**, then adjust the service-parameter L5 = 50 °C as well  
☞ L5 ca. 5 - 10 °C less than C6a

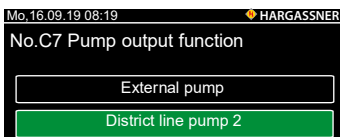

No. C7 Pump output function  
• External pump  
☞ System is heated to the temperature set in parameter C6a  
☞ External heat circuit pump is switched on at release temperature (service setting L5)  
• District line pump  
☞ District line runs when a heat circuit or HWT pump parameterised for **district line** is switched on

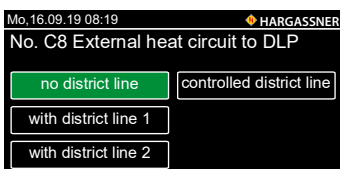

No. C8 External heat circuit to DLP  
☞ District line pump runs if one of the referred pumps run

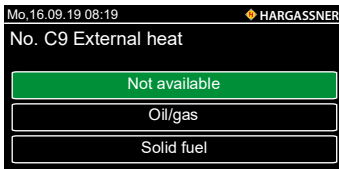

No. C9 External heat

- Not available
- Oil/gas boiler
- Solid fuel boiler

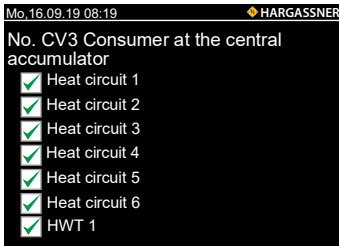

No. CV3 Consumer at the central accumulator

- ☞ Consumer allocation to the central accumulator

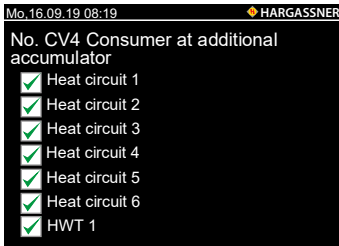

No. CV4/5/6 Consumer at additional accumulator

- ☞ Consumer allocation to the additional accumulator
- ☞ The parameters are only displayed if an additional accumulator is available
  - ☞ As only 1 additional accumulator is possible, only one of these parameters is displayed at a time

## 10.5 Parameter D - general

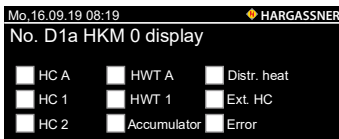

No. D1a Selection regarding display options at connected HKM 0

- Parameter No. D1b at connected HKM 1
- Parameter No. D1c at connected HKM 2



No. D1f Switching on the automatic pellet consumption display

- ☞ When **Available** is selected, customer parameter no. 30 and the extended **Info/consumption display** info page are also enabled

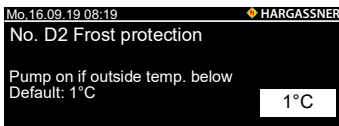

No. D2 Frost protection

- ☞ Heat circuit pumps are switched on when the value drops below the set value
- ☞ Heat circuits with mixers are adjusted to the **D3** parameter temperature



No. D3 Frost protection

- ☞ Flow temperature when parameter **D2** is not reached

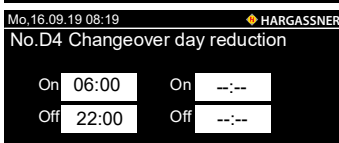

No. D4 Changeover day reduction

- ☞ Changeover point at which time the outside-temperature reduction logic changes from night to day settings (customer settings 12 and 13)



No. D5a Ash suction

- Not available
- With ash bin
- Without ash bin

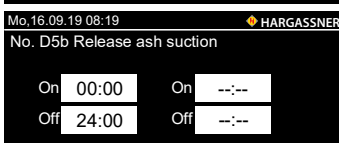

No. D5b Release ash suction

- ☞ The fully automatic ash suction process is only performed within the set time

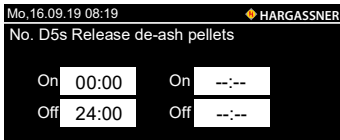

No. D5s Release de-ash pellets

☞ The fully automatic ash suction process is only performed within the set time

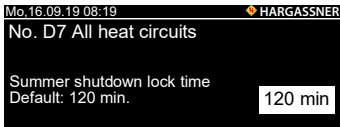

No. D7 Summer shutdown lock time of all heat circuits

Duration of the switch-off delay for summer switch-off

☞ If the outside temperature rises above 16 °C for the duration of the set time (customer setting no. 11), the system switches off



No. D8 Summer time

☞ Automatic changeover from summer to winter time

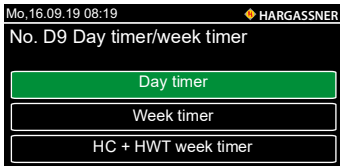

No. D9 Day timer/week timer

☞ Display day or week timer in the customer settings

- Day timer: Heat circuits and HWT on day timer
- Week timer: Heat circuits on week timer, HWT on day timer
- HC + HWT week timer: Heat circuits and HWT on week timer

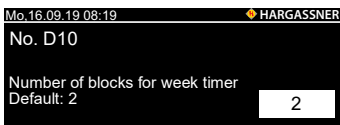

No. D10 Number of blocks for week timer

☞ Display in the customer settings

☞ Range: 1 - 7

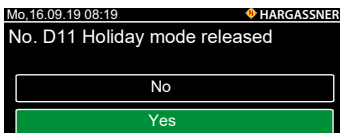

No. D11 Holiday mode released

☞ Holiday mode released in the customer settings

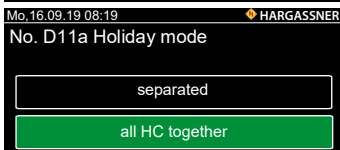

No. D11a Holiday mode

☞ Switch off all the heat circuits together or separately

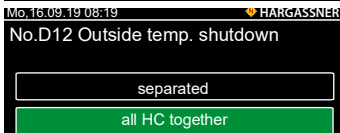

No. D12 Outside temp. shutdown

☞ Outdoor temperature switch-off values individually or for all heat circuits together

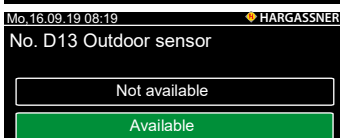

No. D13 Outdoor sensor

☞ Set whether an outdoor sensor is available

☞ Set to **not available** for active, external heat circuits

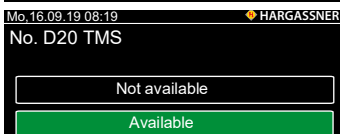

No. D20 Temperature monitor stoker auger

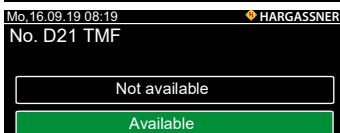

No. D21 Temperature monitor in the fuel storage room

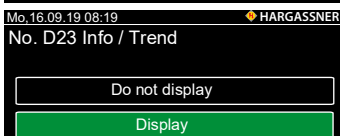

No. D23 Info / Trend

☞ Specify whether the graphical representation of records in the **Info / History** menu field should be shown

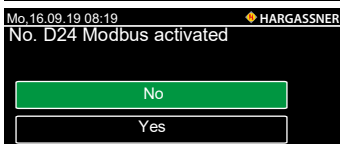

No. D24 Modbus activated

☞ Specify whether a Modbus is available

☞ Only visible when a Modbus ID card is inserted

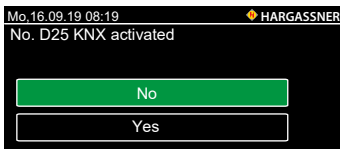

#### No. D25 KNX activated

- ☞ Specifying whether a KNX building controller is available
- ☞ Only visible when a KNX ID card is inserted

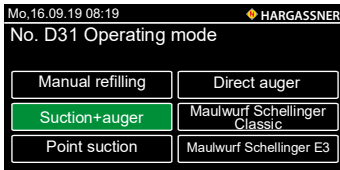

#### No. D31 Setting the pellet boiler operating mode

- Day hopper is filled manually
- Day hopper is automatically filled via auger and vacuum turbine
- Day hopper is automatically filled via point suction
- Boiler is automatically filled by the direct auger
- Day hopper is filled automatically by the **Schellinger** external extraction system

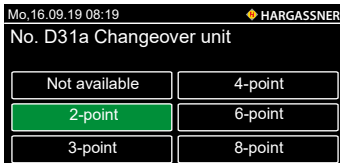

#### No. D31a Changeover unit for feeding wood pellets

- Not available
- 2-point / 3-point / 4-point / 6-point / 8-point

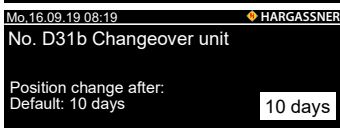

#### No. D31b Position change of changeover unit



#### No. D31c Set the changeover unit's system

- Belimo (AUE)
- Step motor (AUP)

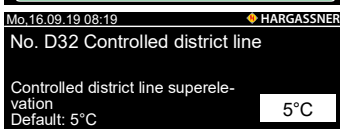

#### No. D32 Controlled district line

- ☞ If there is a demand from a heat circuit - parameterised on a controlled district line - then the flow temperature of the controlled district line is increased by the set value

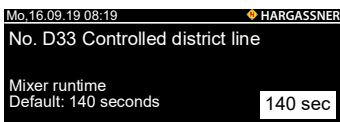

#### No. D33 Controlled district line mixer runtime

- ☞ Mixer runtime from the closed to the open status
- ☞ Range: 10 - 300 sec.

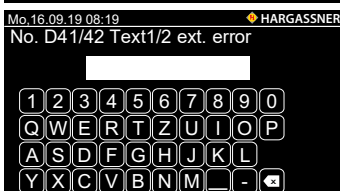

#### No. D41 Text1 external error

- ☞ Text of the external error output on the display

#### No. D42 Text2 external error

- ☞ Text of the external error output on the display

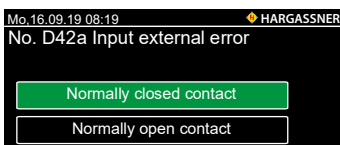

#### No. D42a Input external error

- ☞ Setting whether the external input is normally closed or normally open

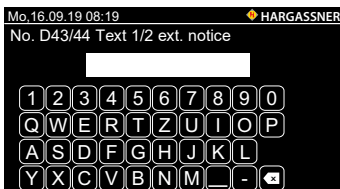

#### No. D43 Text 1 external notice

- ☞ Text of the external notice output on the screen

#### No. D44 Text 2 external notice

- ☞ Text of the external notice output on the screen

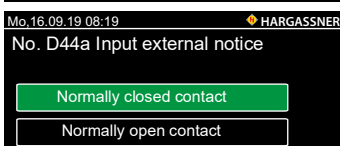

#### No. D44a Input external notice

- ☞ Setting whether the external input is normally closed or normally open

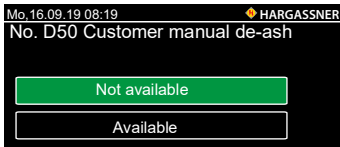

No. D50 Customer manual de-ash  
 ☞ Set whether de-ashing is carried out manually

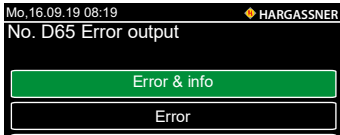

No. D65 Error output

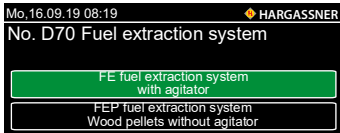

No. D70 Fuel extraction system  
 ☞ Specify whether the fuel extraction should be performed with or without an agitator

## 10.6 Parameter E - languages

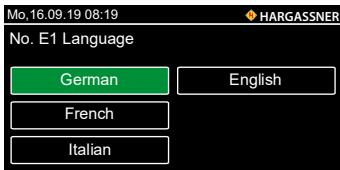

No. E1 Language  
 ☞ Language selection

## 10.7 Parameter G - differential control

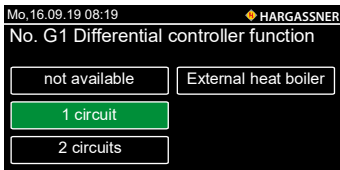

No. G1 Differential controller function

- Not available
- 1 circuit
- 2 circuits
- External heat boiler

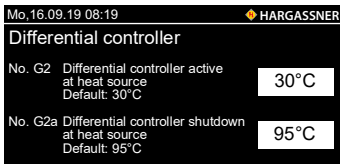

No. G2 / G2a Differential controller active / differential controller switch-off  
 No. G2b Differential controller activated with external heat boiler  
 ☞ Set at which temperature (sensor S1) the differential control should become active

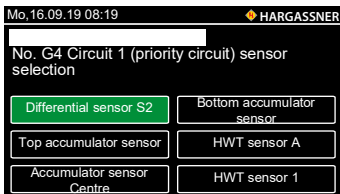

No. G4 Circuit 1 (priority circuit) sensor selection  
 ☞ Set which sensor should be used for differential control

- Differential sensor S2
- Accumulator sensor top / mid. / bott.
- HWT sensor A
- HWT sensor 1

☞ Also valid for G5 circuit 2 (non-priority circuit)

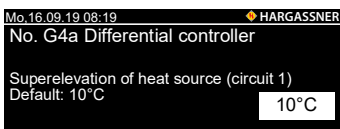

No. G4a Differential controller increase  
 ☞ Set at which temperature the differential control should become active  
 ☞ Circuit 1 is activated when the sensor temperature (S1) is higher than the temperature at the parametrised sensor (commissioning engineer setting G4) by the preset value  
 ☞ Range: 1 - 50 °C  
 ☞ Also valid for G5 circuit 2 (non-priority circuit)

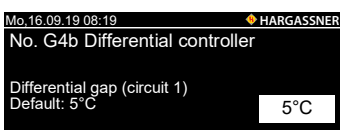

No. G4b Differential controller differential gap  
 ☞ Indicate what the differential temperature between the two sensors being used has to be. If it has dropped below, circuit 1 is activated  
 ☞ Range: 1 - 50 °C  
 ☞ Also valid for G5 circuit 2 (non-priority circuit)

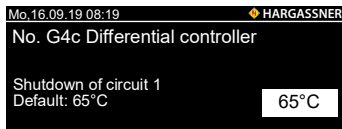

No. G4c Differential controller shut down

- ☞ Set from which temperature the differential controller should be deactivated
- ☞ Range: 10 - 95 °C
- ☞ Also valid for G5 circuit 2 (non-priority circuit)

No. G5 - G5c, see G4 - G4c

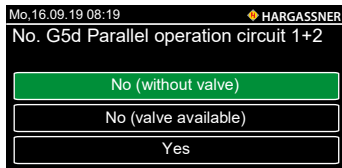

No. G5d Parallel operation circuit 1+2

- No (without valve)
- No (valve available)
- Yes

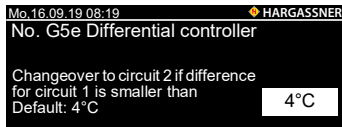

No. G5e Differential controller changeover circuit 2

- ☞ Set from which temperature difference (circuit 1) on the lower-level circuit 2 is switched over
- ☞ Range: 1 - 20 °C

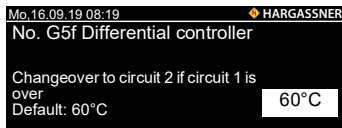

No. G5f Differential controller changeover circuit 2

- ☞ Set from which temperature (circuit 1) on the lower-level circuit 2 is switched over

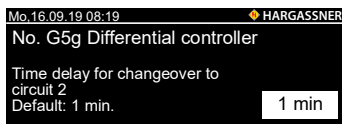

No. G5g Differential controller time delay for changeover

- ☞ Setting the time delay for changeover

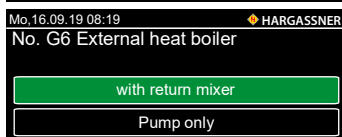

No. G6 External heat boiler

- ☞ Specify whether differential control of the external heat boiler should be carried out using the mixer or the pump

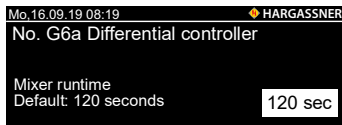

No. G6a Differential controller mixer runtime

- ☞ Set the external heat boiler's mixer runtime
- ☞ Range: 10 - 300 Sec.

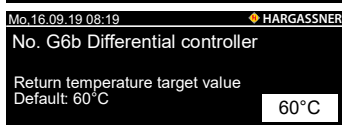

No. G6b Differential controller return temperature

- ☞ Set the external heat boiler's return temperature
- ☞ Observe manufacturer's instructions

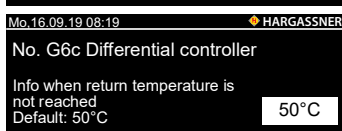

No. G6c Differential controller notice return temperature

- ☞ Specify which temperature the external heat boiler's return temperature has to drop below for a notice to be issued
- ☞ Observe manufacturer's instructions

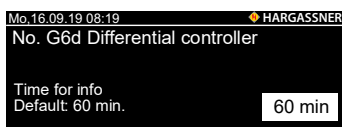

No. G6d Differential controller time for notice

- ☞ Set how long the return temperature of the external heat boiler has to be below the set value for a notice to be issued

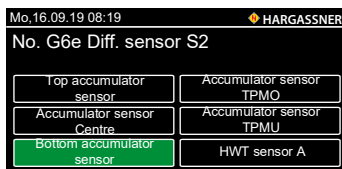

No. G6e Differential sensor S2 external heat boiler

- ☞ Set which sensor should be used for differential control
- Accumulator sensor top / mid. / bott.
- Accumulator sensor centre top (TSCT) / centre bottom (TSCB)
- HWT sensor A

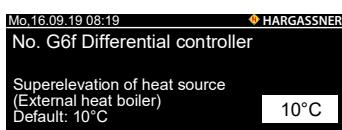

No. G6f Differential controller increase heat source

- ☞ Set from which temperature increase the differential controller is to become active
- ☞ Range: 1 - 50 °C

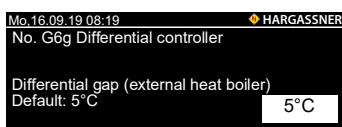

No. G6g Differential controller differential gap

- ☞ Set from which temperature difference between the two sensors being used must be switched
- ☞ Range: 1 - 50 °C

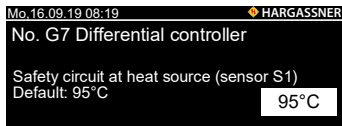

#### No. G7 Differential controller safety circuit

- ☞ If the preset temperature is reached at the parametrised sensor, all the outputs on the differential controller board will be switched off
- ☞ Range: 80 - 105 °C
- ☞ If 95 °C is exceeded at a sensor (excluding S1), then differential control will be deactivated to prevent damage to the pumps

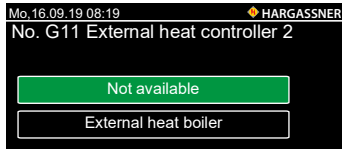

#### No. G11 External heat controller 2

- ☞ Only activated if parameter G1 has been set on **two circuits**
- ☞ If the setting **External heat boiler** is selected, parameters G12 - G17 follow

## 11 Optional remote controls

Using a remote control makes it easy to adjust the room temperature and also the heating and setback settings. The heating temperatures and times can be set and changed with the FR35 and FR40 digital remote controls. One heat circuit may be parametrised per remote control, which can be parametrised with or without using room temperature.

- 1 heat circuit on the extension board (**HC A/B** digital remote control only)
- 2 heat circuits per extension module (**HKM 0 - 2**)
- 2 heat circuits per heat circuit controller (**HKR 0 - 15**)

### 11.1 Digital remote control FR40

With the FR40, all the heat circuit functions available on the boiler can be set from wherever the remote control is in the user's living space.

#### Operation states:

##### OFF



The heat circuit is switched off (except for frost protection).

##### AUTOMATIC



The heat circuit is operated according to set times.

##### PERMANENT REDUCTION (in automatic mode)



The heat circuit is in permanent reduced mode.

##### PERMANENT HEATING (in automatic mode)



The heat circuit is in permanent heating mode.

##### 1x HEATING (heating on a single occasion)



The heat circuit switches to permanent heating mode on a single occasion and automatically reverts to automatic mode at the next preset heating time.

##### 1x REDUCTION (reduction on a single occasion)



The heat circuit switches to permanent reduced mode on a single occasion and automatically reverts to automatic mode at the next preset heating time.

##### Fine adjustment of room temperature:



Increase of up to 3°C



Decrease of up to 3°C

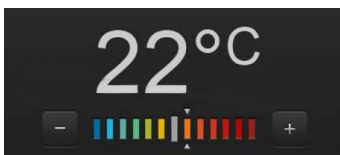
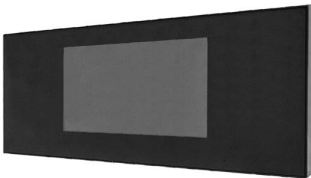

## 11.2 Digital remote control FR35



The remote control is also available in a wireless version.

The following selection options are available on the remote control only when the boiler is in **Automatic** mode:

- Selection of the heat circuit's operating mode
- Selection of modes at remote control

### Operation states:

#### OFF



The heat circuit is switched off (except for frost protection).

#### AUTOMATIC



The heat circuit is operated according to set times.

#### PERMANENT REDUCTION (in automatic mode)



The heat circuit is in permanent reduced mode.

#### PERMANENT HEATING (in automatic mode)



The heat circuit is in permanent heating mode.

#### 1x HEATING (heating on a single occasion)



The heat circuit switches to permanent heating mode on a single occasion and automatically reverts to automatic mode at the next preset heating time.

#### 1x REDUCTION (reduction on a single occasion)



The heat circuit switches to permanent reduced mode on a single occasion and automatically reverts to automatic mode at the next preset heating time.

#### Fine adjustment of room temperature:



/ : Increase / decrease by 2 or 3°C

#### Fault lamp:



Lights up if an error occurs on the boiler

#### Display parameters:

Select which temperature should be shown on the room device (FR35).

- HWT temperature 1 - A
- Accumulator fill level

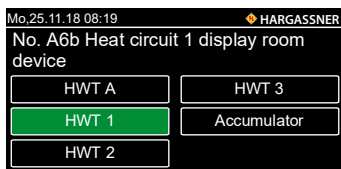

## 11.3 Analogue remote control FR25



Only for HKM or HKR heat circuits.

The following selection options are available on the remote control only when the boiler is in  Automatic mode:

#### Selection of the heat circuit's operating mode with the rocker switch



The heat circuit switches to permanent reduced mode.



The heat circuit switches to day / week mode.



The heat circuit switches to permanent heating mode.

#### Fine adjusting the room temperature with the rotary knob









Increase / decrease by 2 or 3°C.

#### Fault lamp:



Lights up if an error occurs on the boiler.

## Chapter IV: Cleaning

 	<p style="text-align: center;"><b>D A N G E R</b></p> <p><b>Risk of injury</b></p> <p><b>Risk of crushing and amputation due to moving parts</b></p> <ul style="list-style-type: none"> <li>• Refrain from accessing augers or motors when the boiler is switched on.</li> <li>• Fix and lock the ash container on the system correctly.</li> <li>• Do not work on the system while people are in the danger zone. Secure and lock storage room.</li> <li>• Only clean the augers and remove blockages using suitable tools and when the system is switched off.</li> <li>• Wear safety shoes.</li> <li>• Observe the storage room sticker.</li> </ul>
	<p style="text-align: center;"><b>D A N G E R</b></p> <p><b>Danger to life</b></p> <p><b>Electric shock from contact with live terminals</b></p> <ul style="list-style-type: none"> <li>• Observe information signs.</li> <li>• Disconnect the power supply prior to any cleaning or work.</li> <li>• Check that no voltage is present using a voltmeter.</li> <li>• Switch off the system and secure it against restarting.</li> </ul>
  	<p style="text-align: center;"><b>D A N G E R</b></p> <p><b>Risk of injury</b></p> <p><b>Risk of crushing or injuries from reaching into the danger zone during recommissioning</b></p> <ul style="list-style-type: none"> <li>• While working on the system, switch off the main power switch, lock it using a padlock and carry the key with you for the duration of any work.</li> <li>• After triggering main power switch, do not reach into the danger zone without thinking.</li> <li>• Hand out the key for a lock to the authorised person only.</li> <li>• Rectify error.</li> <li>• When recommissioning, check that nobody is in the danger zone or storage room.</li> </ul>
 	<p style="text-align: center;"><b>D A N G E R</b></p> <p><b>Risk of fire, explosion</b></p> <p><b>Risk of burning from inflammable materials</b></p> <ul style="list-style-type: none"> <li>• Do not spray any inflammable sprays on hot surfaces (e.g. lubricating moving parts in the combustion chamber). Spray drops can cause explosive fire.</li> <li>• Do not use any inflammable lubricants.</li> <li>• Allow system (combustion chamber) to cool down.</li> </ul> <p><b>Fire in the vacuum cleaner sack</b></p> <ul style="list-style-type: none"> <li>• Let the ash cool down prior to vacuum cleaning.</li> </ul>

### ATTENTION



#### Material damage

##### Formation of dust due to system leakages

- Clean sealing surfaces with industrial alcohol and a dry and soft (scratch-free) cloth only.
- Make sure the cleaning agent has evaporated before commissioning.

### ATTENTION



#### Material damage

##### Dirt, boiler breakdown due to escaping ash when overfilling the ash container

- Regularly empty and clean the ash container.
- Properly position and close the ash container.

- ☞ Small cracks may occur in the refractory in regular operation. These are stress cracks that form an expansion joint. This cracking is important and does not lead to any functional impairment. Hence there is also no claim under warranty.
- ☞ The specified cleaning and maintenance intervals are absolutely necessary for safe and clean operation of the system. Observe the state regulations and resulting chimney sweep's inspection and sweeping intervals dictated by these regulations.

## 1 Maintenance contract

If you sign a maintenance contract with Hargassner Ges mbH, the annual cleaning and maintenance takes place during the annual service performed by personnel authorised by Hargassner. Service must be carried out regularly by the manufacturer (every one to three years) depending on your country's regulations. This service must be carried out by the manufacturer or by trained and authorised individuals.

- ☞ To ensure optimum operation of the system, extensive cleaning of the boiler is required
  - ☞ At least once a year
  - ☞ After a set number of operating hours in the event of an error
- ☞ The cleaning intervals will change or shorten depending on the composition of the fuel and if low-grade material is used

## 2 Weekly/monthly cleaning

### 2.1 Weekly intervals

- Carry out a visual check of the entire system, including the fuel storage chamber, once a week
  - ↳ Rectify identified defects immediately
- Empty ash box (1) if required

	NOTE
Dispose of any ash according to country-specific regulations. If unarmful fuels are used, the ash is a high-quality mineral fertiliser and can be used for composting. Watch out for ember pockets.	

### 2.2 Monthly intervals

- ⇒ See "Monthly checks" in the commissioning book
- Check the safety equipment (2) (TRVB H118)
  - ↳ This may be waived if an annual inspection is performed by the manufacturer
  - ⇒ See "Maintenance contract" on page 56.
- Check the flue pipe (3)
- Ensuring proper condition of the boiler room
- Readiness of portable fire extinguishers
- Ensuring proper storage of ash

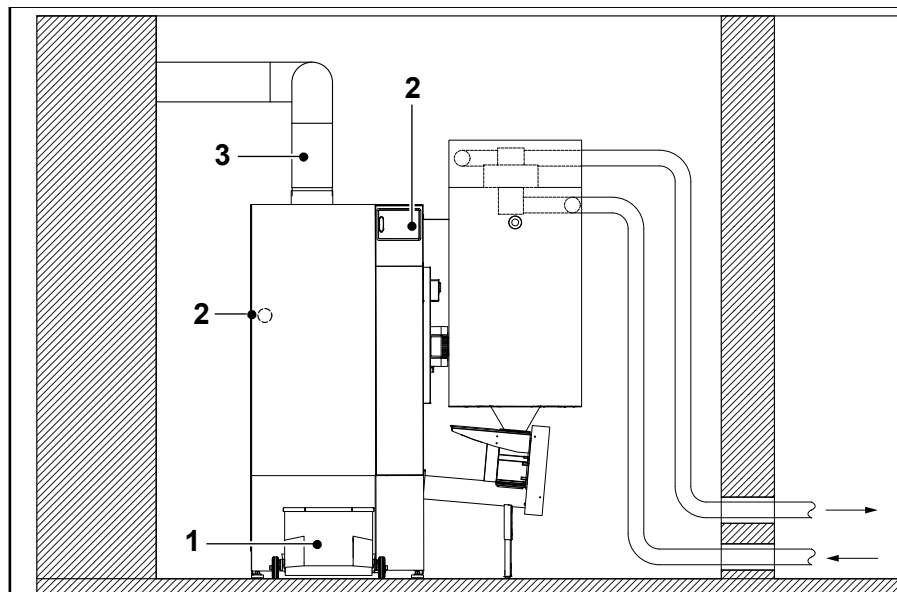

Item	Maintenance tasks	Frequency
1	Clean and empty ash box (optionally diagonal ash auger)	as required
2	Check safety devices (main switch, safety valve)	Once a month (waived if a maintenance contract has been signed)
3	Check and clean flue pipe (more often at excessive contamination)	1x monthly

## IV Cleaning

### 3 Annual cleaning

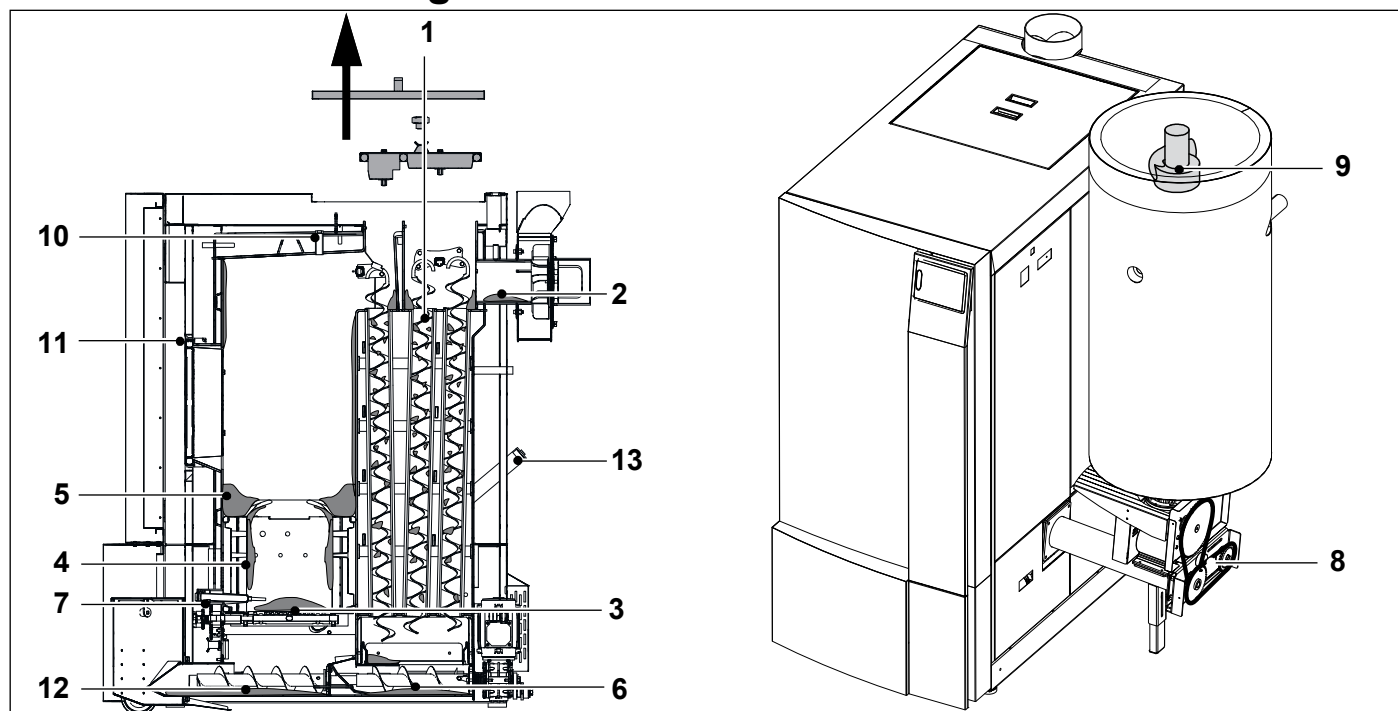

Item	Cleaning tasks	Item	Cleaning tasks
1	Pull out turbulators, tap off and clean the turbulator space	8	Grease stoker chain and check chain tension
2	Vacuum exhaust fan and flue pipe	9	Clean the pellet vacuum turbine and filter
3	Clean rust holes	10	Clean lambda sensor and combustion chamber sensor
4	Clean combustion chamber with ash cleaner	11	Check sealings
5	Remove and clean flame concentration plate	12	Remove ash under the grate (especially from by the ash grate)
6	Remove maintenance opening and clean fly ash space	13	Clean recirculation with vacuum cleaner
7	Clean ignition	14	Check safety installations (main power switch, safety valve)

Frequency: at least once annually and no later than after 4000 full-load hrs, 8000 partial-load hrs or after a message has appeared on the control unit

☞ Boiler monitoring and cleaning intervals are based on the operation hours and fuel quality. Observe country-specific regulations and the inspection and sweeping intervals dictated by these.

### 3.1 Preparation for cleaning

- Switch off system at the control unit (BCE) (**Off** operating mode)
- Let boiler cool down
- Disconnect the boiler from the power supply (**Off** main switch)

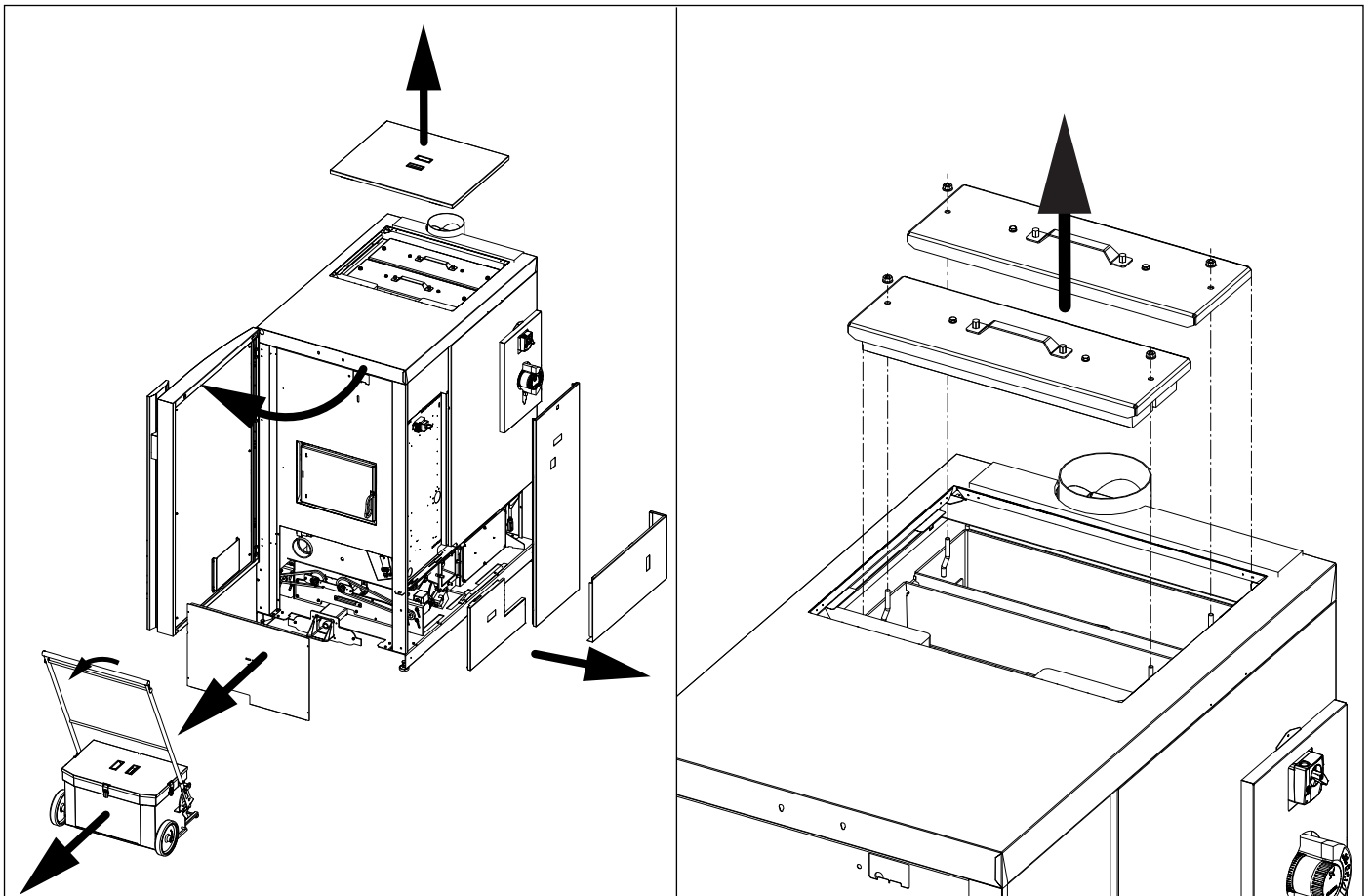

- Remove casing top and maintenance cover
  - Clean maintenance lid over the heat exchanger
- Open the cover door and remove the ash box
- Dismount lower front wall
  - Remove 4 screws
  - Disconnect ash box switch
  - Pull cover forwards
- Remove the cover of the control box
- Remove lower side covers
  - Loosen screw at the back cover of the fly ash space
  - Pull cover backwards and remove
  - Remove insulation
  - Lift cover from the stoker and remove

### 3.2 Cleaning the turbulators and the turbulator chamber

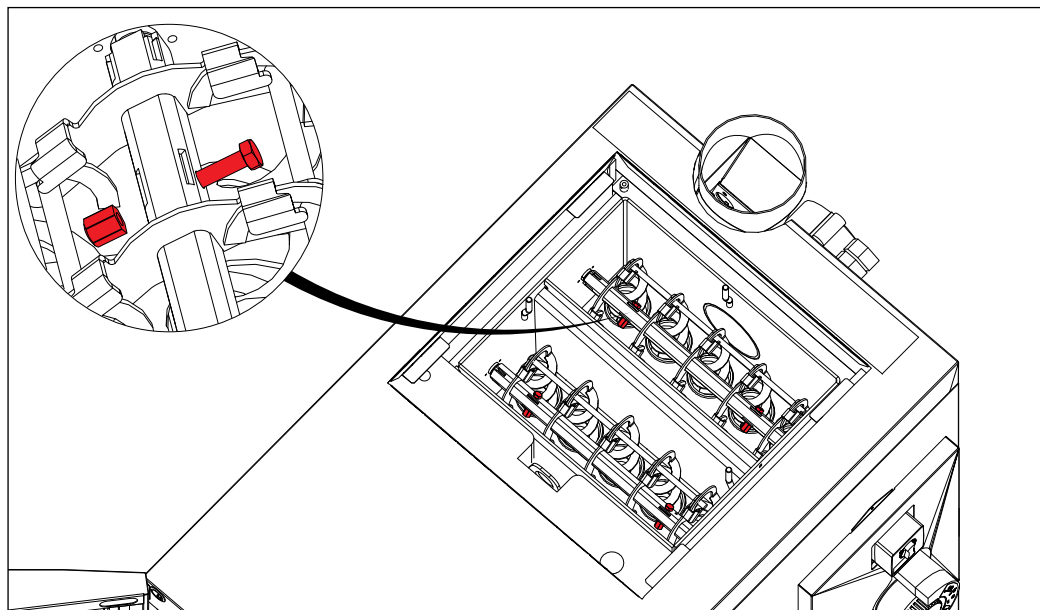

- Loosen the turbulators' fixing points
- Tap turbulators and remove upwards

### 3.3 Cleaning the exhaust fan and the flue pipe

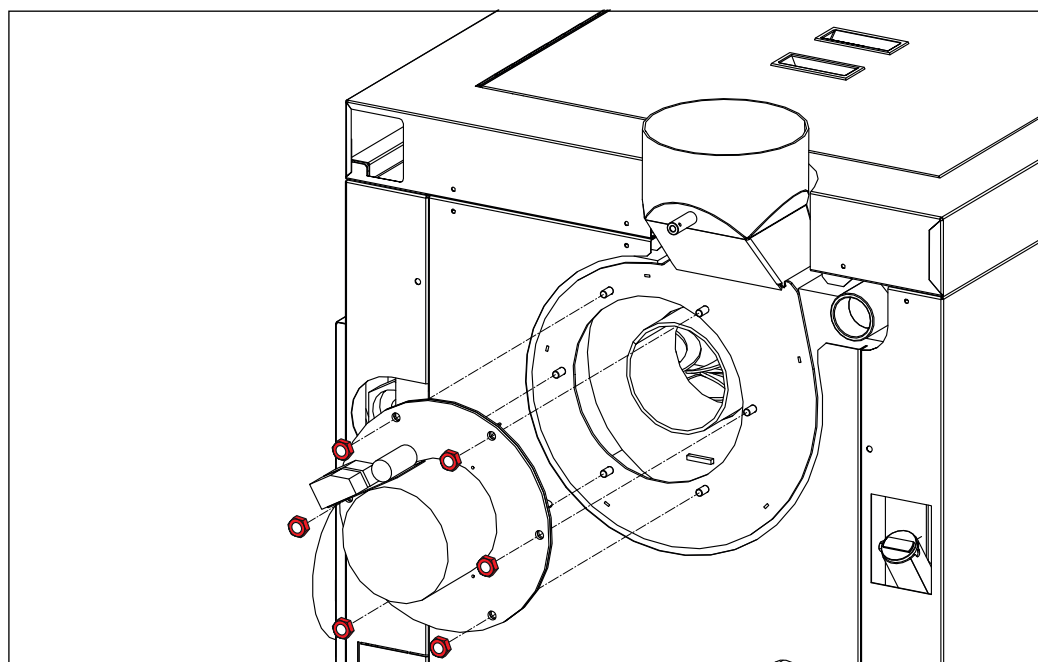

- Disconnect electrical connection from the motor
- Loosen copper nuts and remove exhaust fan backwards
  - ☞ The ring sealing on the exhaust fan housing protects the exhaust fan seal from sticking to the housing
  - ☞ If the exhaust fan sealing gets stuck, replace both it and the ring sealing
- Clean dirt from the flue pipe, housing and impeller
  - ☞ Don't damage the impeller (don't use compressed air)
- Clean recirculation junction of the housing with a vacuum cleaner

### 3.4 Cleaning the lambda sensor and the combustion chamber sensor

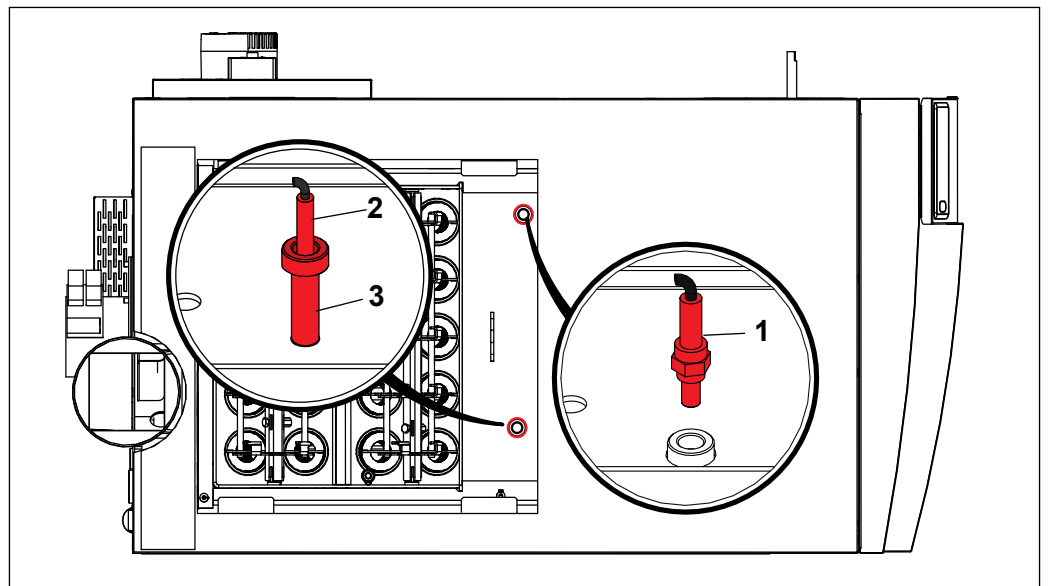

- Disconnect and unscrew the lambda sensor (1)
- Place sensor head down
- Remove dirt with a soft cloth
  - ☞ Debris falls down



#### NOTE

Do not tap the lambda sensor.  
 Do not blow off with compressed air.  
 Do not touch the sensor with sharp items and do not use any chemicals for cleaning (brake cleaning fluid, etc.).

- Pull out the combustion chamber sensor (2) and the ceramic protective pipe (3) if present and wipe them with a soft cloth

### 3.5 Cleaning the combustion chamber and post combustion chamber

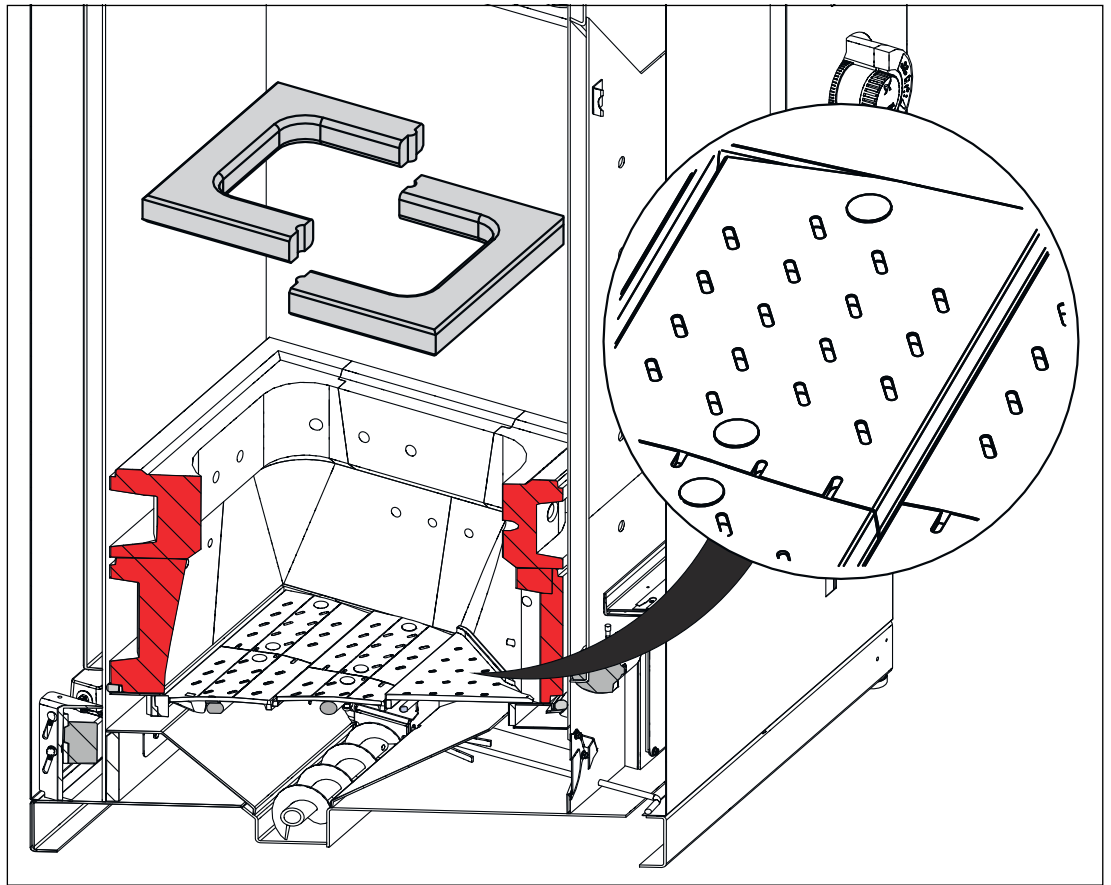

- Open combustion chamber door
- Remove the split flame concentration plate from the combustion chamber
  - ☞ Clean flame concentration plate in the combustion chamber
- Clean the combustion chamber and post combustion chamber with a cleaning poker
- Clean the rotating grates and ensure the holes are free of any dirt

### 3.6 Cleaning the ignitions

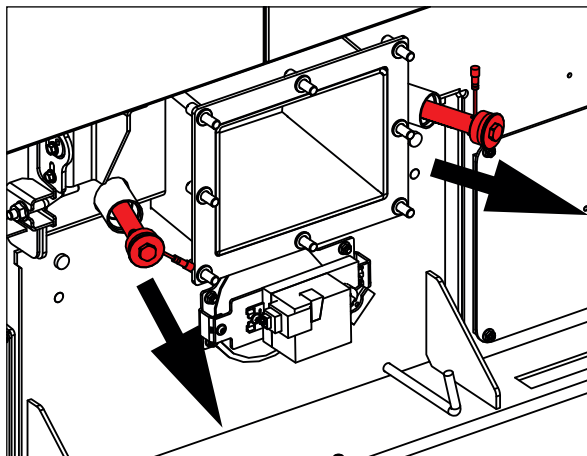

- Loosen electric connection to the ignition
- Unscrew the ignition
- Clean ignition and ignition sleeve (on the boiler) using a vacuum cleaner
  - ☞ Mount ignition hand-tight only

### 3.7 Cleaning the ash chamber

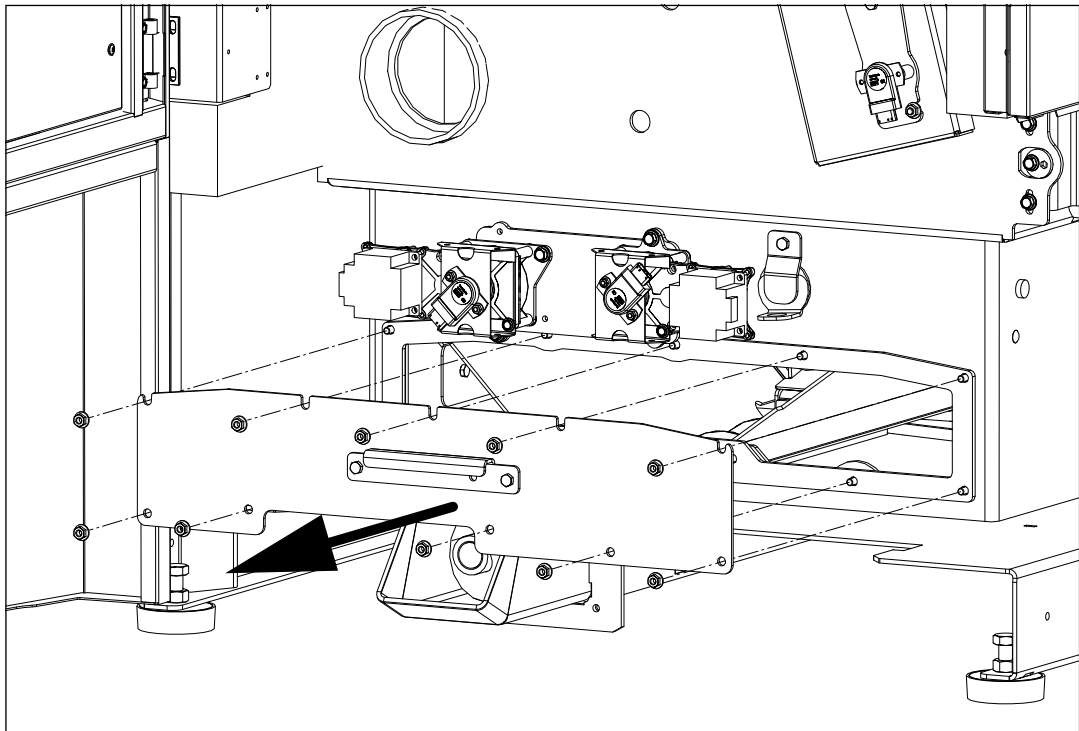

- Loosen the maintenance lid's fastenings and remove it

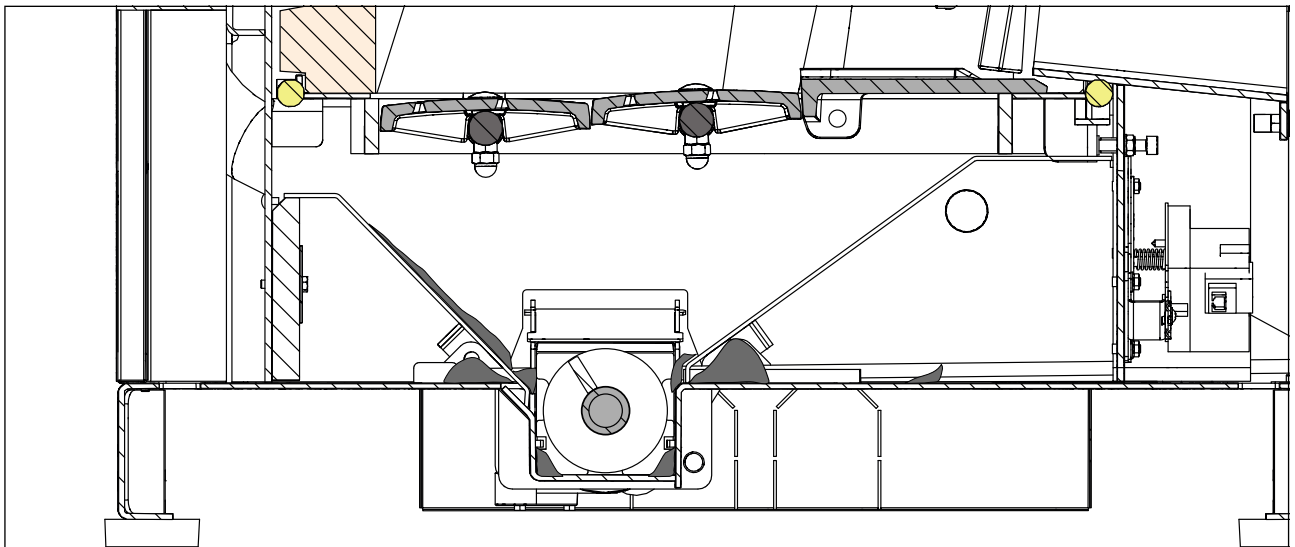

- Remove any accumulated ash and debris from the ash chamber
  - ☞ Especially from under the ash grate

### 3.8 Cleaning the fly ash area

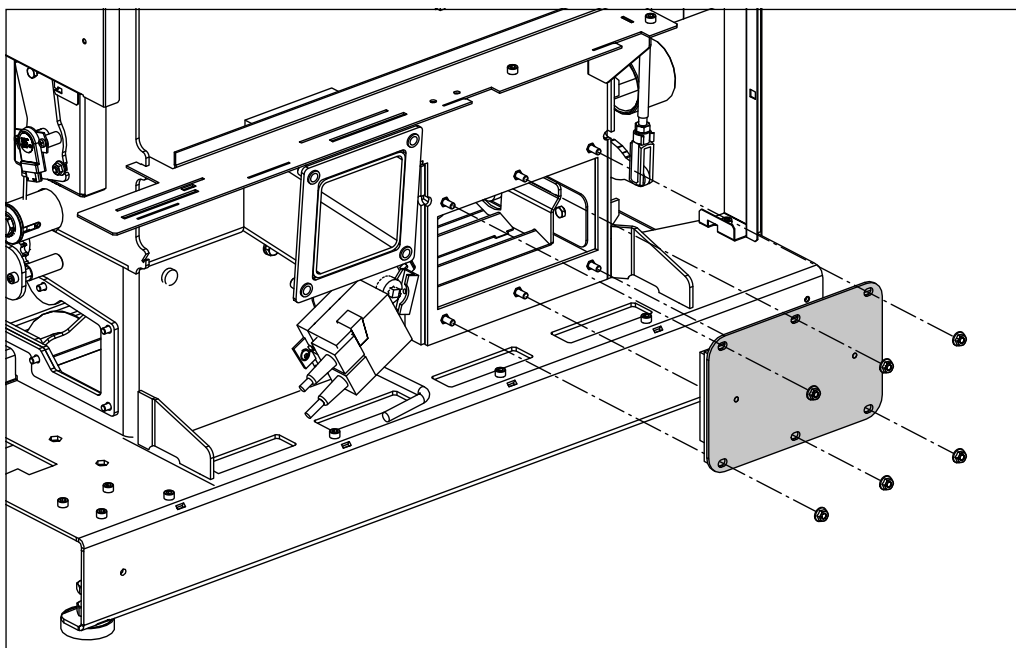

- Loosen the fastenings of the fly ash chamber's cover and remove it

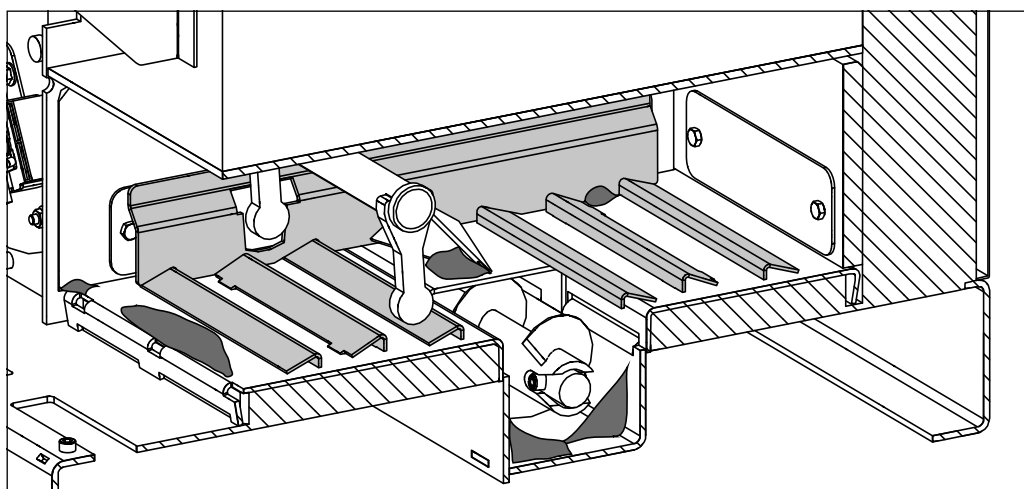

- Remove any ash and debris from the fly ash area

### 3.9 Cleaning the recirculation

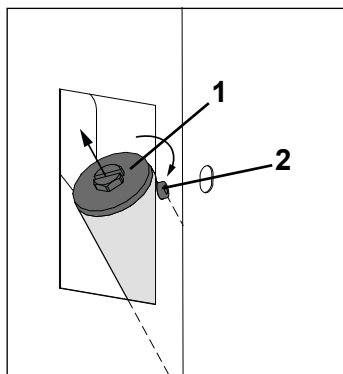

- Mark recirculation settings
- Turn the recirculation slider (1) until the screw can be loosened
- Take the screw (2) out completely
- Pull the recirculation slider (1) out of the tube
- Clean slider of recirculation and tube with vacuum cleaner

### 3.10 Cleaning the pellet vacuum turbine

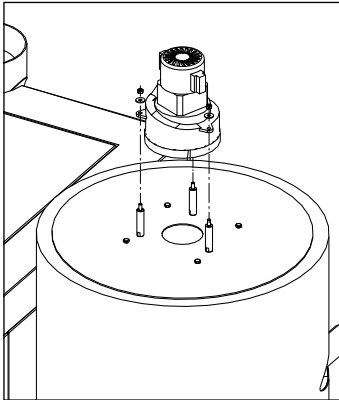

- Remove the day hopper's casing cover
- Remove the insulation at the top
- Disconnect plug of vacuum turbine
- Loosen the clamp of the return air hose and remove the hose from the vacuum turbine
- Loosen tension ring from day hopper
- Remove lid and vacuum turbine upwards
- Loosen the vacuum turbine's fixation points and remove them from the cover
- Remove dust from sieve, vacuum turbine and return air hose
- Re-assemble system after cleaning

### 3.11 Emptying the ash box

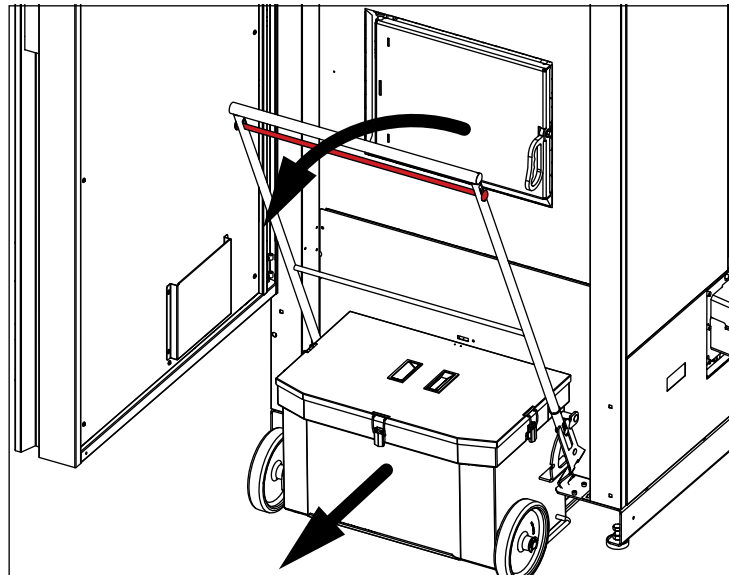

- Open the cover door
- Pull the ash box's release lever upwards
- Pull the handle backwards until it clicks into the transport position
  - ☞ Now the ash box can easily be transported to the emptying point
- Place the transport handle in the emptying position
- Open the cover's fasteners and remove the cover
- Empty the ash box
- Put the cover back on and secure it with the fasteners
- Put the handle back into the transport position
- Reattach the ash box to the system
  - ☞ It is locked on both sides by folding up the transport handle into the heating mode position

### 4 Disposal information

#### 4.1 Disposal of created ash

- ❑ Ash must be disposed of according to your national waste management regulations (Austria: AWG Waste Management Act)
  - ☞ If natural wood is used as a fuel, then the ash can be regarded as a high-quality mineral fertilizer and can be used for composting
  - ☞ **Caution:** watch out for ember pockets

#### 4.2 Disposal of wear and spare parts

- ❑ Disposal of the wear and spare parts must be according to your national waste management regulations (Austria: AWG Waste Management Act).
  - ☞ Only use equivalent spare parts approved by Hargassner Ges mbH

#### 4.3 Disposal of system components

- ❑ Ensure environmentally compatible disposal in accordance with country-specific regulations (Austria: AWG Waste Management Act)
- ❑ Recyclable materials must be cleaned and sorted before being passed on for recycling
  - System (boiler)
  - Fuel extraction system
  - Insulation material
  - Electrical and electronic parts
  - Plastics

# Chapter V: Troubleshooting

	A T T E N T I O N
	<p><b>Material damage</b></p> <p><b>Damage to the system due to defective parts or incorrect operating states</b></p> <ul style="list-style-type: none"> <li>• Contact Hargassner Ges mbH or the commissioning engineer in case of higher power consumption, higher temperatures or vibrations of motors, unusual noises or smells, release of safety devices, etc.</li> <li>• Perform mandatory maintenance tasks regularly.</li> </ul>

## 1 Information and error display

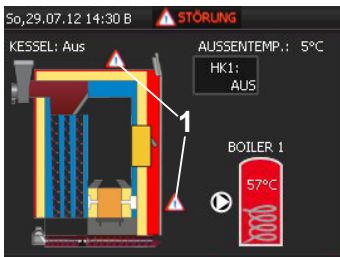

Information and error messages are displayed on the touchscreen.

- ☞ A warning triangle appears on the standard menu at the position where the error has occurred (1)
- ☞ Yellow triangle = information
- ☞ Red warning triangle = error

The following instructions for rectifying errors are intended for the system operator.

If it is not possible to rectify the error through the operator, the commissioning engineer / Hargassner must be informed.

## 2 Viewing the error list

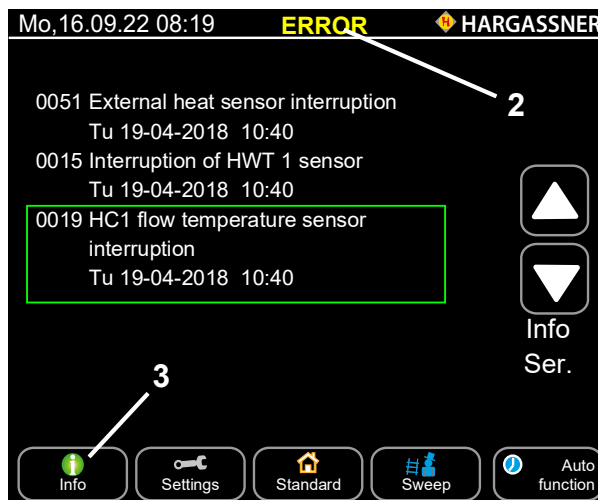

- ☐ If error messages occur, press **Error (2)**
  - ☞ Displays the error list (current errors)

## 3 Acknowledging and rectifying an error

- ☐ Press the **Info (3)** button
- ☐ Follow the instructions to rectify the error
- ☐ After rectifying the error, press the  button

### 4 BCE failure



#### DANGER

##### Danger to life

##### Electric shock from contact with live terminals

- Observe information signs.
- Before starting work, check that no voltage is present using a voltmeter.

A BCE failure can occur due to a defective fuse, missing power supply or missing connection to the main board.

- Check the voltage supply and fuse
    - ☞ Fuse F16F13 on the main board
    - ☞ Mains supply of terminal L / PE / N
  - Check LED H6H7 on the main board
    - ☞ Check CAN bus cable
    - ☞ Replace BCE or cable
- ⇒ [See Electrical manual](#)

### 5 Temporary emergency operation (restart without HW test)

If the error is clearly a result of a defective boiler board and the connected component works correctly, the control unit may be run in **temporary emergency operation** (until the service department arrives) without a hardware test of the component in question.

- Ignore the hardware test as soon as the error message appears or
- Switch to **Manual** operating mode on the control unit
- Switch to the respective manual parameter
- Confirm **Without HW test**

Boiler operates with max. 60% output

# Appendix

	<b>NOTE</b>
	<b>Please be advised that we do not accept responsibility for damage or malfunctions resulting from non-observance of the manual.</b>

## 1 Copyright notice

This manual should be kept confidential. The manual is intended solely to be used by authorised persons. The transfer to third parties is prohibited and is liable to compensation. All rights reserved, also translations. No part of this manual may be reproduced or processed, duplicated or distributed using electronic systems without the permission of Hargassner Ges mbH.

### 1.1 Measures prior to commissioning by the operator

Licensing requirements for safe operation and accident prevention regulations must be observed! Work on hydraulic systems must be carried out only by personnel with specialised knowledge and experience in hydraulics.

### 1.2 Liability

This **wood biomass boiler** has been manufactured and tested in accordance with recognised safety regulations and the latest engineering standards, and is therefore safe to operate. However, improper use may cause lethal hazards for the operator or third parties or may damage the unit and other property.

This **wood biomass boiler** must only be used as intended, when it's in technically perfect condition and with safety and danger in mind. Especially errors tending to affect the safety shall be cleared immediately.

Liability for the **wood biomass boiler** functioning correctly will always be borne by the owner or operator if the device has been improperly maintained or repaired by individuals who have not been authorised by Hargassner Ges mbH or has been handled or operated in a manner that does not comply with the device's intended use.

In the interest of the continuous development and improvement of our products, we reserve all rights to make technical changes to the information contained in our printed material.

These kinds of changes, errors and misprints do not constitute grounds for any claims for damages.

Only original Hargassner spare parts and accessories must be used.

In addition to the guidelines in this operation manual, please follow general guidelines for safety and accident prevention. Hargassner Ges mbH is not liable for any damage resulting from failure to observe the instructions and guidelines in this manual. This boiler system's reliability is guaranteed by **Hargassner Ges mbH** vast experience, very modern production methods and extremely high quality standards. **Hargassner Ges mbH cannot** be held liable for safe operation of the **wood biomass boiler** if it has been handled or operated in a manner that does not comply with its intended use.

The customer has NO warranty claims:

- if heating fuel is missing wrong or of poor quality
- if damages occur through incorrect assembly, misuse or lack of maintenance
- if the installation manual and operation manual is NOT observed
- for defects that do not affect the performance of the system. E.g.: Paint defects,....
- for damages arising from force majeure like fire, flooding, lightning stroke, electrical surge, power loss, ...
- if a non-licensed installer or non-licensed plumber installs the product
- for damage caused by air pollution, heavy dust, aggressive vapours, oxygen corrosion (non diffusion-tight plastic tubing), installation in inappropriate rooms (laundry room, hobby room, ...) or continued use despite the occurrence of a defect

To ensure repair or maintenance work relating to defects and malfunctions not mentioned in this manual is carried out properly, always contact **Hargassner Ges mbH** beforehand.

The warranty and liability terms in **Hargassner Ges mbH** general terms and conditions will not be extended because of information in this manual.

The **safety instructions** in this manual must be observed. Only use Hargassner replacement parts or equivalent replacement parts that have been approved by **Hargassner Ges mbH**. Constant technical innovations mean that we reserve the right to modify the design of our products and services without notice.

Please make sure you include the **serial number** of your **wood biomass boiler** in any queries.

We wish you all the best with this **wood biomass boiler** from Hargassner.



# Declaration of Conformity

**HARGASSNER**  
HEIZTECHNIK DER ZUKUNFT



Manufacturer:	<p><b>HARGASSNER Ges mbH</b>  <b>Anton Hargassner Straße 1</b>  <b>4952 Weng</b>  <b>AUSTRIA</b></p> <p>The manufacturer is also the party authorised to compile the technical documentation</p>
Type of machine:	<b>Boiler for solid fuels with automatic loading</b>
Type:	<p><b>PELLET BOILERS</b>  <b>Eco-PK 130-230</b>  <b>optional with fuel extraction RAS 150-800, RAPS, PWB, AUP</b>  <b>Optional eCleaner particle filter available</b></p>
Standard:	<b>from 10.08.2020</b>
Directives:	<p>The manufacturer hereby declares that the products mentioned above comply with the regulations laid down in the following European directives:</p> <ul style="list-style-type: none"> <li>• Machinery Directive 2006/42/EC</li> <li>• Low Voltage Directive 2014/35/EU</li> <li>• EMC Directive 2014/30/EU</li> <li>• Ecodesign directive 2009/125/EG</li> <li>• Ecodesign directive (EU) 2015/1189</li> </ul>
Standards:	<p>Conformity with the guidelines is verified through the manufacturer's compliance with the relevant requirements, which are laid down in the following standards among other places:</p> <ul style="list-style-type: none"> <li>• EN 303-5:2021 Heating boilers for solid fuels, manually and automatically stoked, nominal heat output of up to 500 kW</li> <li>• EN ISO 12100:2010 Safety of machinery - General principles for design - Risk assessment and risk reduction</li> <li>• ÖNORM EN 60335-2-102:2016 Household and similar electrical appliances - Safety - Particular requirements for gas, oil and solid-fuel burning appliances having electrical connections</li> </ul>
Place, date:	Weng, 21.07.2020
Name:	Dr. Johann Gruber
Signature:	
Function:	Head of Development

---

**notes**

Your expert for **PELLET | WOOD LOG | WOOD CHIP** HEATING

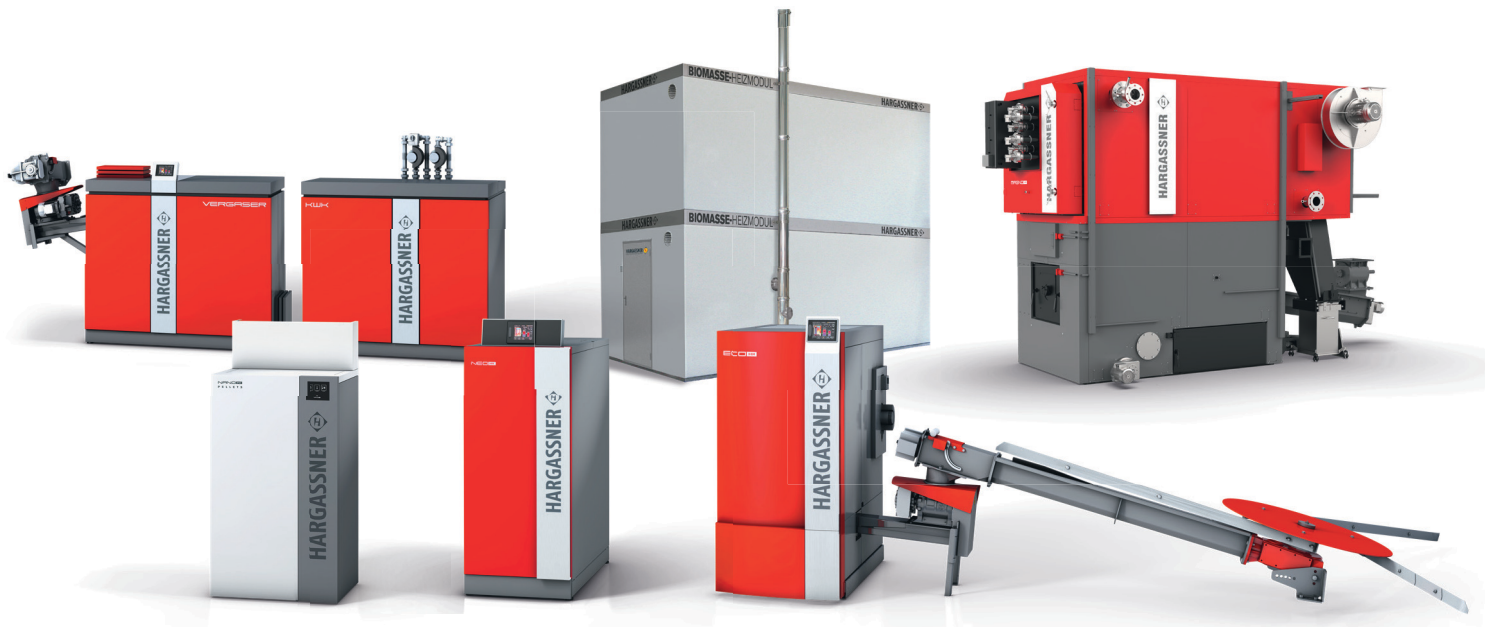
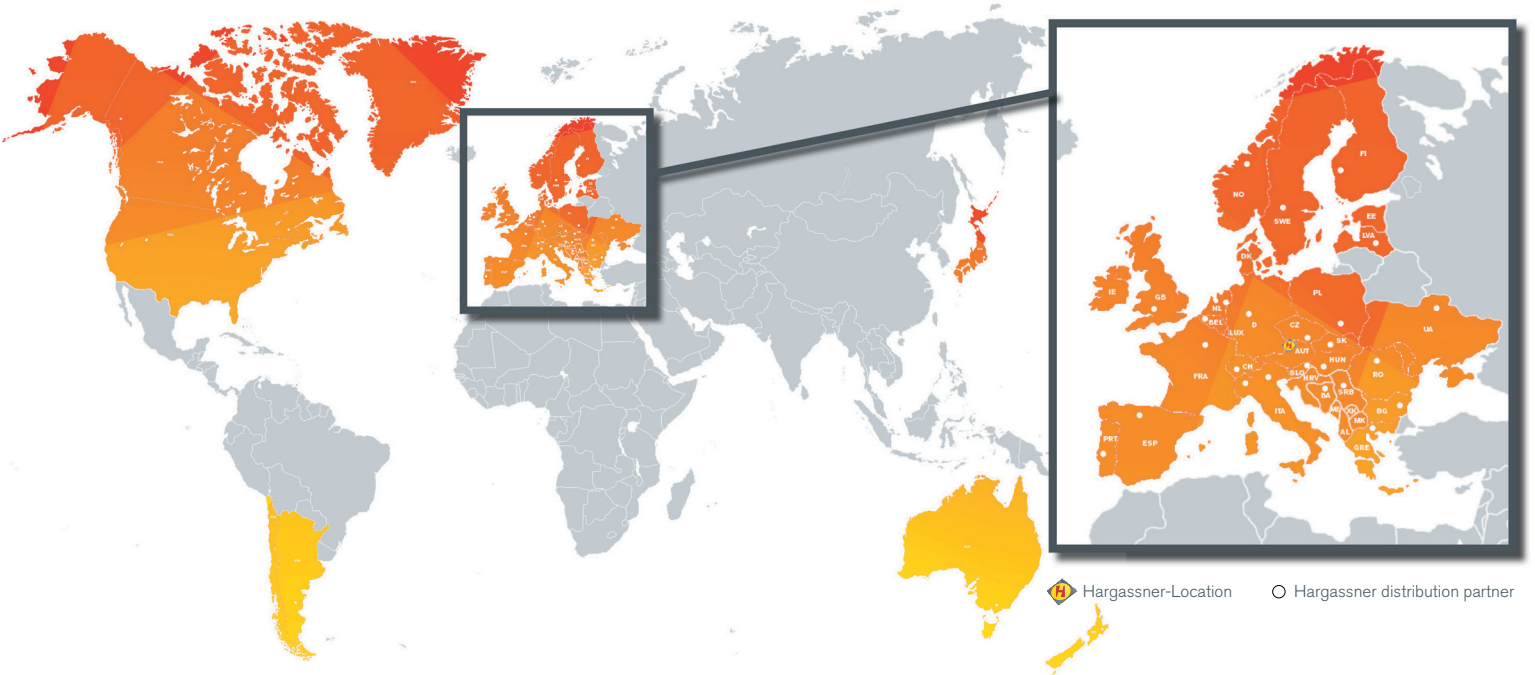

[hargassner.com](http://hargassner.com)

#### AUSTRIA

**HARGASSNER Ges mbH**  
Anton Hargassner Strasse 1  
A-4952 Weng  
Tel. +43 (0) 77 23 / 52 74  
Fax +43 (0) 77 23 / 52 74 - 5  
[office@hargassner.at](mailto:office@hargassner.at)

#### GERMANY

**HARGASSNER DE GmbH**  
Heraklithstraße 10a  
D-84359 Simbach/Inn  
Tel. +43 (0) 77 23 / 52 74  
Fax +43 (0) 77 23 / 52 74 - 5