



GILLES Energie und Umwelttechnik GmbH & Co KG

Koaserbauerstraße 16
 A - 4810 Gmunden
 Tel.: (+43) 7612 / 73 76 0 - 0
 office@gilles.at

Project description	Woodchips / Pellets Heating System		
Type	HPK-RA 15-160	NG01 - NG03 OPTION BH3 OPTION key switch	
Job number			
Software version	V2.0		
Site ref.	Standard		
Power supply	400Vac/50Hz, 3Ph+N		
Max. pre-fuse	16 A		
Input cable	5x2,5mm ²		
Project name	HPK V1.1		
Created on	21.12.2011		
Edit date	23.05.2012	By (Abbreviation) waw	Number of pages 24

			Date	21.12.2011	Gilles Energie u. Umwelttechnik Koaserbauerstraße 16 A - 4810 Gmunden Tel.: (+43) 7612 / 73 76 0 - 0	Standard	Cover sheet	HPK-RA 15-160	= ALG General
			Ed.	waw					+
Modification	Date	Name	Appr	Original					Page 1

Table of contents

Gilles_IHV_01

Plant	Mounting location	Page	Page description	Date	Edited by
=ALG General		1	Cover sheet	14.06.2011	waw
		2	Table of contents	14.06.2011	waw
		3	General informations	01.06.2011	waw
=SLP Wiring diagram	+EC01 Switch cabinet	1	HZS 555-S - Display / CPU	01.06.2011	waw
	+EC01 Switch cabinet	2	HZS 522 - Power unit	06.06.2011	waw
	+EC01 Switch cabinet	3	Extension module	01.06.2011	waw
	+EC01 Switch cabinet	10	Power supply	14.06.2011	waw
	+EC01 Switch cabinet	11	Display / CPU	14.06.2011	waw
	+EC01 Switch cabinet	20	Main current circuit 400V	14.06.2011	waw
	+EC01 Switch cabinet	21	Power unit X1 - X5	14.06.2011	waw
	+EC01 Switch cabinet	22	Power unit X6 - X10	14.06.2011	waw
	+EC01 Switch cabinet	23	Power unit X11 - X15	14.06.2011	waw
	+EC01 Switch cabinet	24	Power unit X16 - X21	14.06.2011	waw
	+EC01 Switch cabinet	25	Power unit X22 - X28	14.06.2011	waw
	+EC01 Switch cabinet	26	Power unit X29 - X33	14.06.2011	waw
	+EC01 Switch cabinet	27	Power unit X34 - X38	14.06.2011	waw
	+EC01 Switch cabinet	28	Power unit X39 - X45	14.06.2011	waw
	+EC01 Switch cabinet	31	Internal Controller Expansion Card	14.06.2011	waw
+EC01 Switch cabinet	41	Internal Buffer/Boiler Module	14.06.2011	waw	
+EC01 Switch cabinet	51	Internal Buffer/Boiler Module	14.06.2011	waw	
=STAP Pin-connection diagram		1	Pin-connection diagram +HR-X1	14.06.2011	waw
		2	Pin-connection diagram +HR-X2	14.06.2011	waw
		3	Pin-connection diagram +HR-X3	14.06.2011	waw
		4	Pin-connection diagram +HR-X3.1	14.06.2011	waw

1

3

-A1
/11.1

HZS 555-S
Touch Display, Heating Control



- X1 Power supply
- X2 CAN Bus
- X3 RS 232
- X4 Ethernet
- X5 Mini USB type B
- X6 USB 1.1

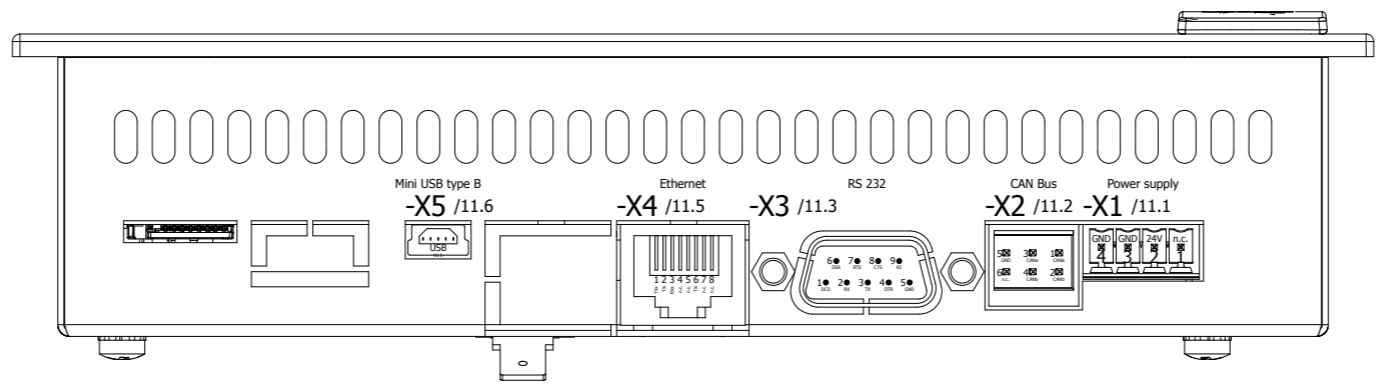

=ALG+/3

Modification	Date	Name	Date	21.12.2011	 Gilles Energie u. Umwelttechnik Koaserbauerstraße 16 A - 4810 Gmunden Tel.: (+43) 7612 / 73 76 0 - 0	Standard	Woodchips / Pellets Heating System	HZS 555-S - Display / CPU	HPK-RA 15-160	= SLP	Wiring diagram
			Ed.	waw						+ EC01	Switch cabinet
			Appr								Page
			Original								1

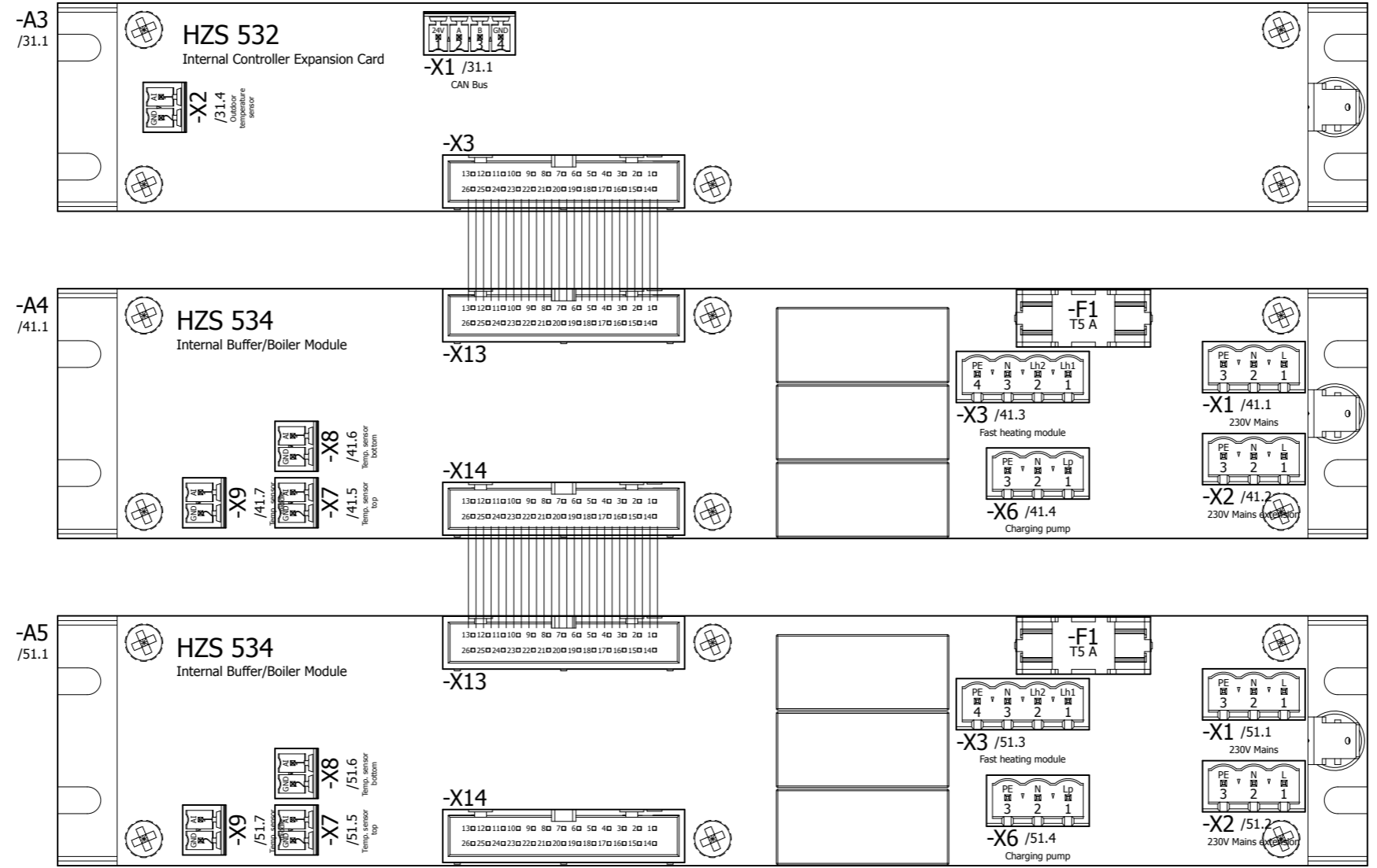

- X1 CAN Bus
- X2 Outdoor temperature sensor
- X1 230V Mains
- X2 230V Mains extension
- X3 Fast heating module
- X6 Charging pump
- X7 Temp. sensor top
- X8 Temp. sensor bottom
- X9 Temp. sensor middle
- X1 230V Mains
- X2 230V Mains extension
- X3 Fast heating module
- X6 Charging pump
- X7 Temp. sensor top
- X8 Temp. sensor bottom
- X9 Temp. sensor middle

Modification	Date	Name	Date	21.12.2011	Gilles Energie u. Umwelttechnik Koaserbauerstraße 16 A - 4810 Gmunden Tel.: (+43) 7612 / 73 76 0 - 0	Standard	Extension module	= SLP Wiring diagram + EC01 Switch cabinet HPK-RA 15-160	Page	3
			Ed.	waw		Woodchips / Pellets Heating System				
			Appr							

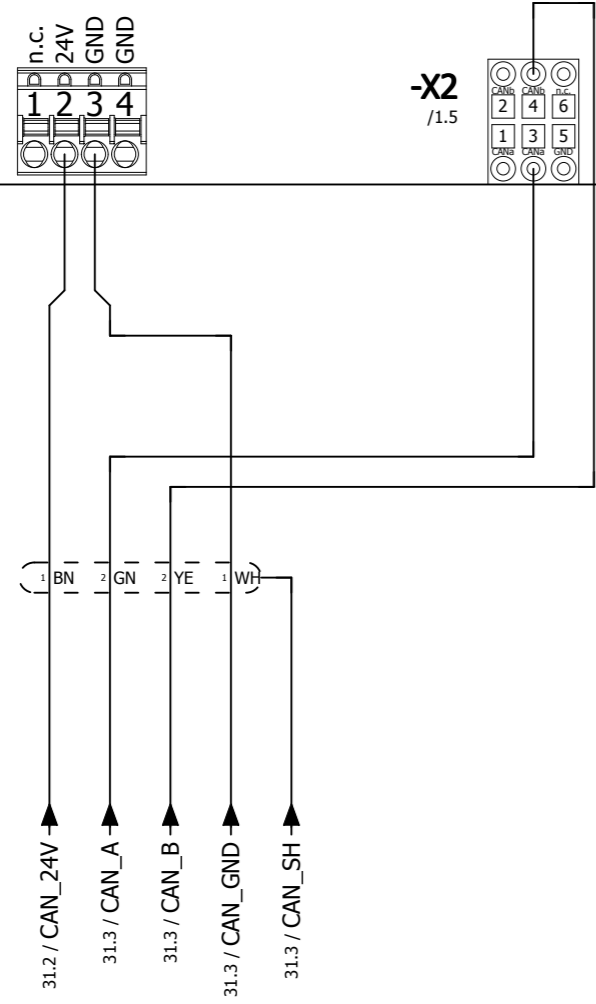
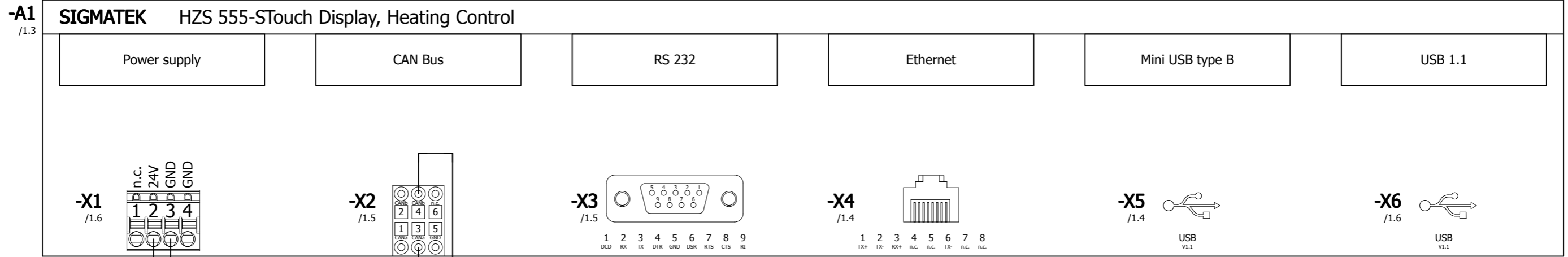

CAN Bus

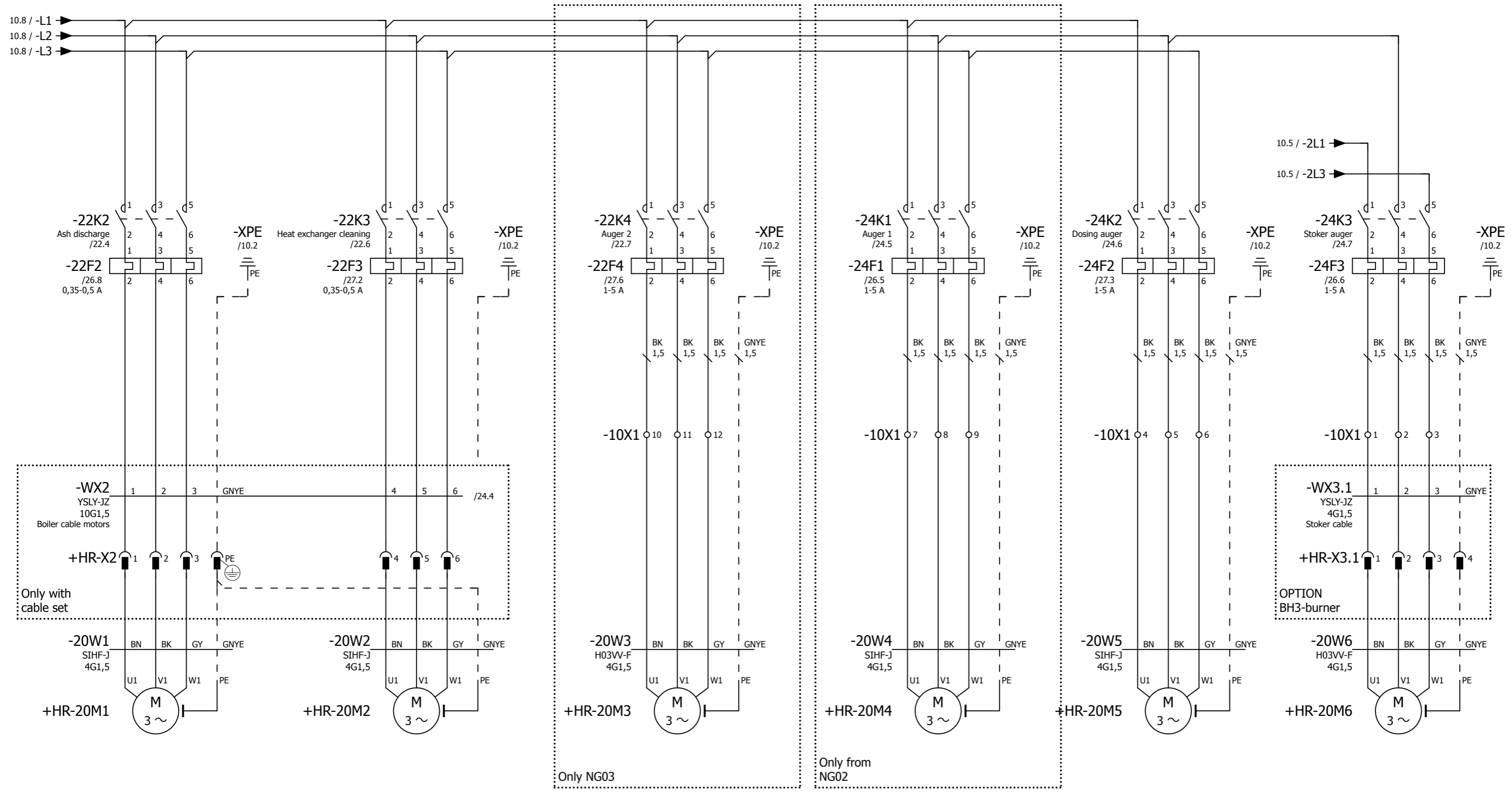

Ash discharge

Heat exchanger cleaning

Auger 2

Auger 1

Dosing auger

Stoker auger

-A2 /2.2 **SIGMATEK HZS 522 Power unit**

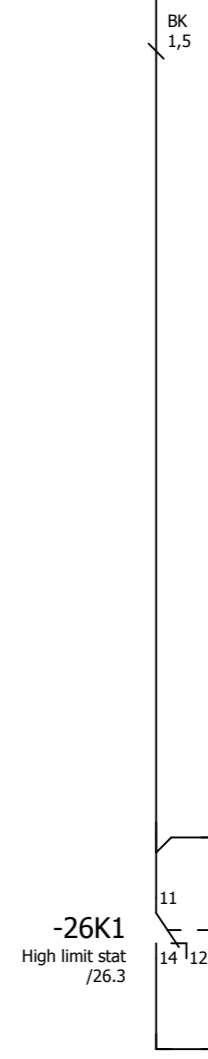
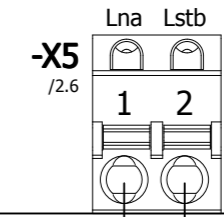
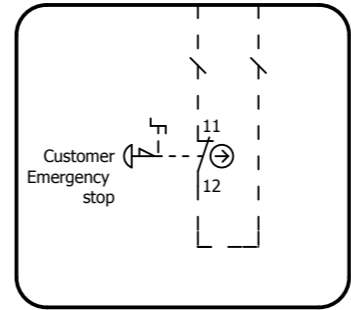
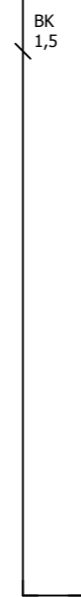
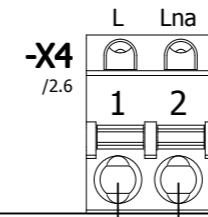
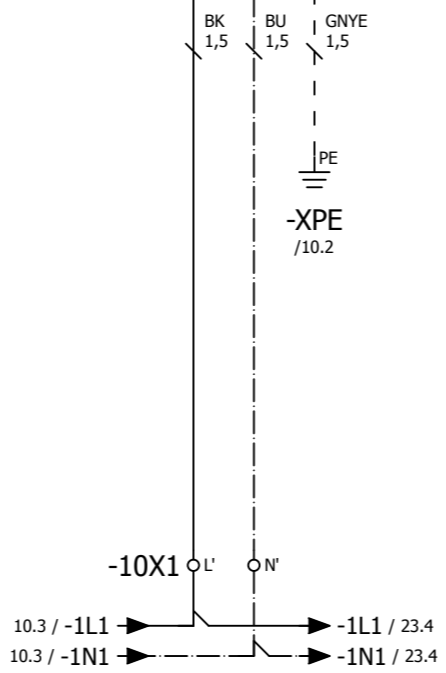
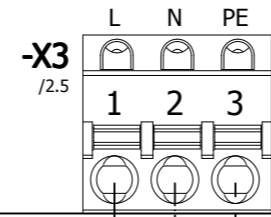
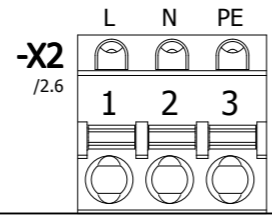
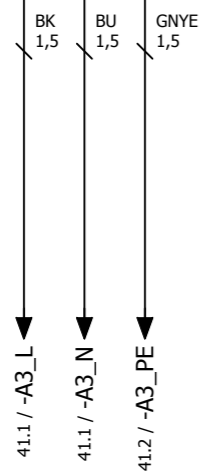
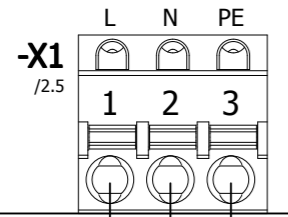
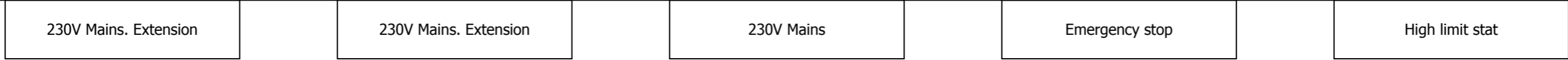

Date	21.12.2011
Ed.	waw
Appr	
Original	
Modification	Date
	Name

GILLES Gilles Energie u. Umwelttechnik
 Koaserbauerstraße 16
 A - 4810 Gmunden
 Tel.: (+43) 7612 / 73 76 0 - 0

Standard
 Woodchips / Pellets Heating System

Power unit X1 - X5

HPK-RA 15-160

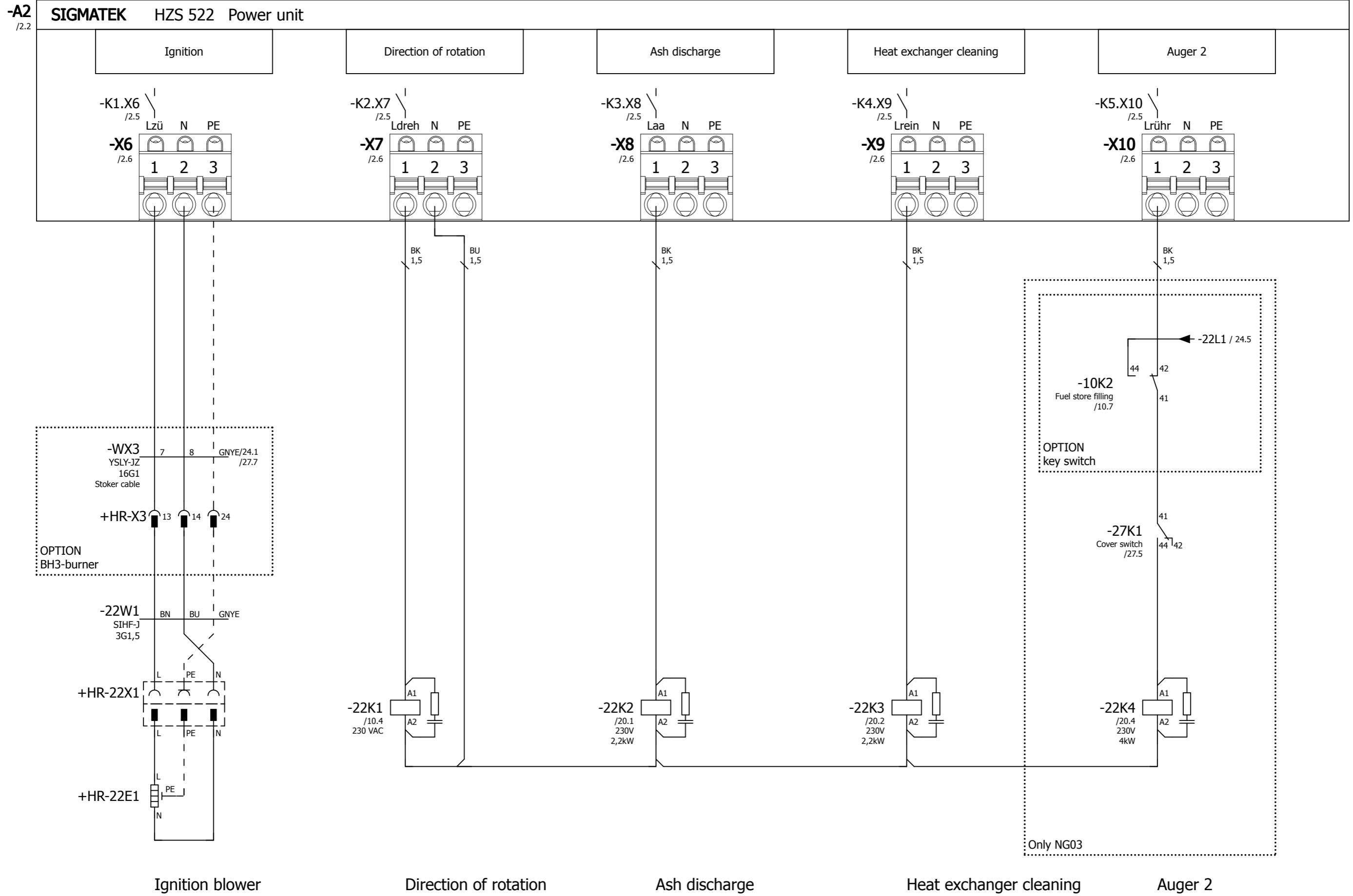

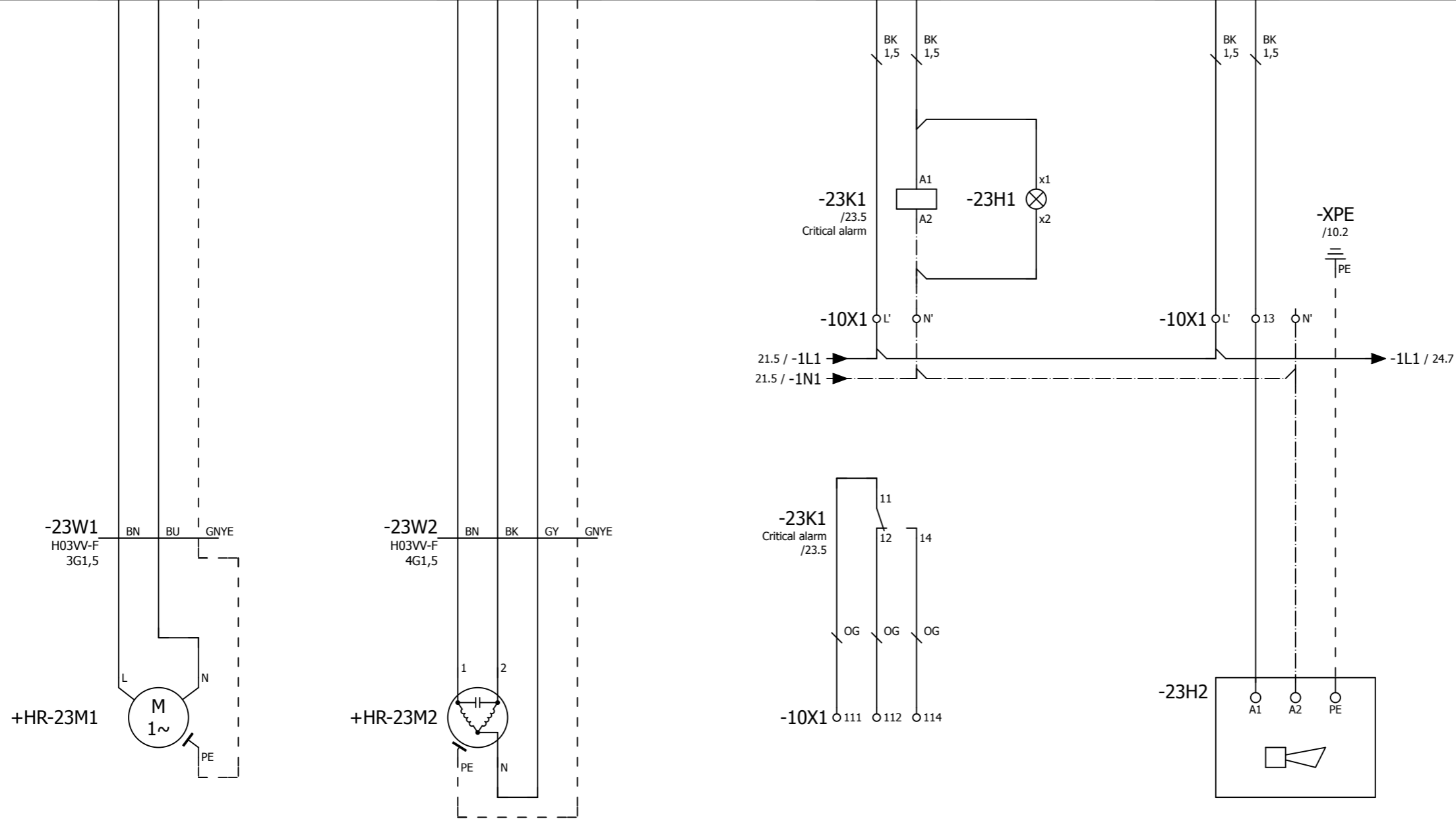
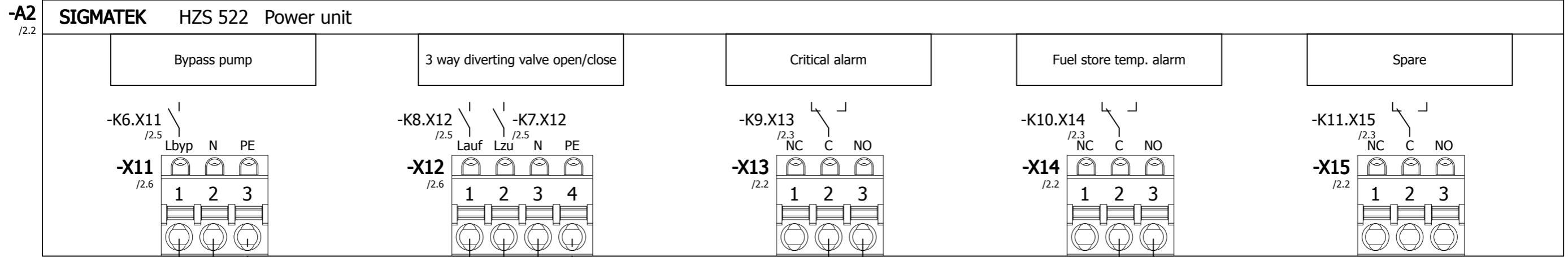

Bypass pump

3 way diverting valve

Critical alarm

Fuel store temp. alarm

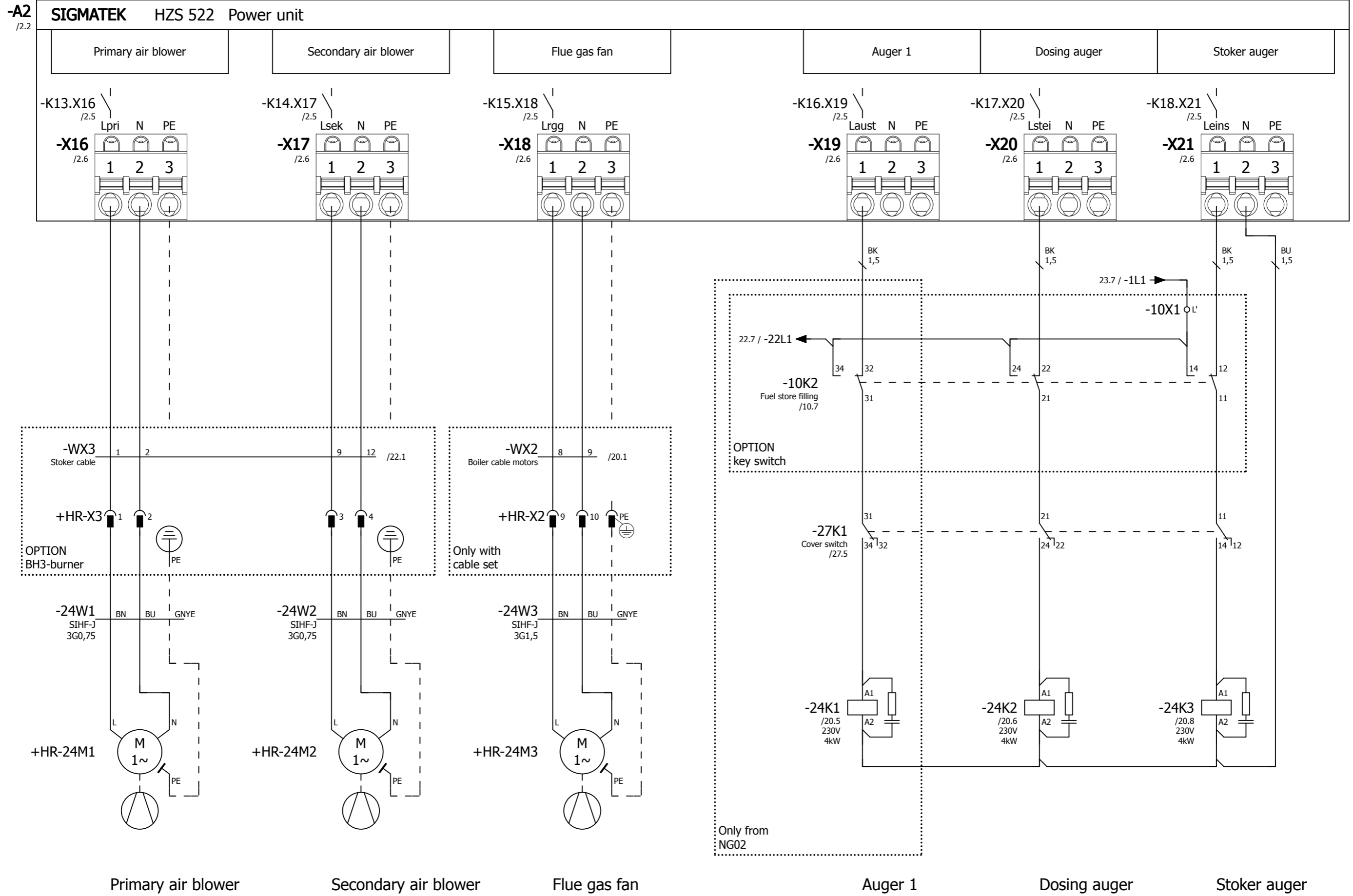

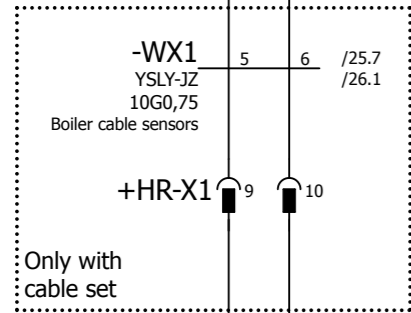
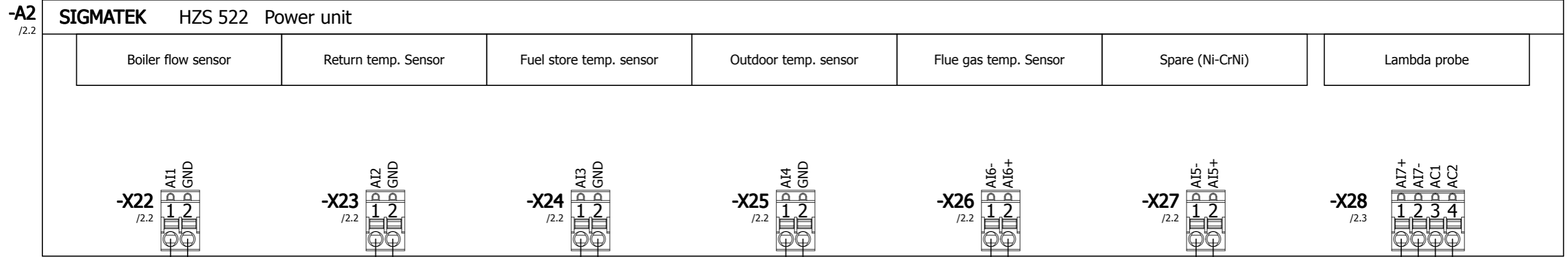

+HR-25R1
PT1000

Boiler flow sensor

+HR-25R2
PT1000

Return temp. Sensor

+HR-25R3
PT1000

Fuel store temp. sensor

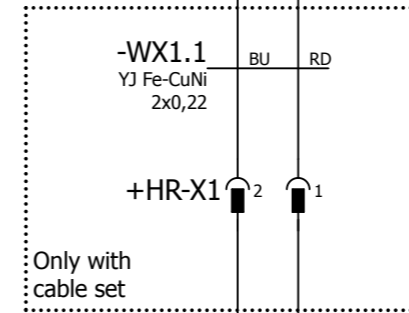

+HR-25B1
Fe-CuNi

Flue gas temp. Sensor

+HR-25B2
Ni-CrNi

Spare (Ni-CrNi)

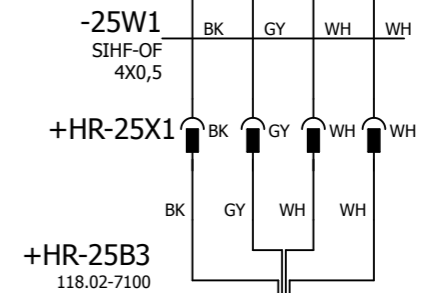
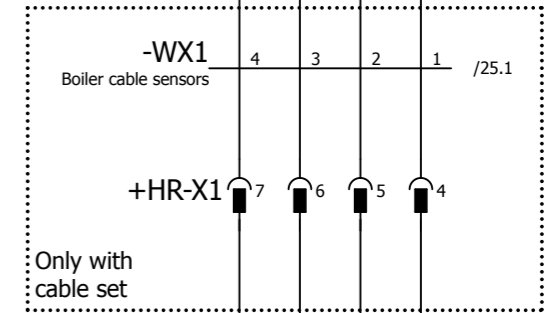

Lambda probe

Date	21.12.2011
Ed.	waw
Appr	
Original	
Modification	
Date	
Name	

GILLES Energie u. Umwelttechnik
Koaserbauerstraße 16
A - 4810 Gmunden
Tel.: (+43) 7612 / 73 76 0 - 0

Standard
Woodchips / Pellets Heating System

Power unit X22 - X28

HPK-RA 15-160

-A2 /2.2 **SIGMATEK HZS 522 Power unit**

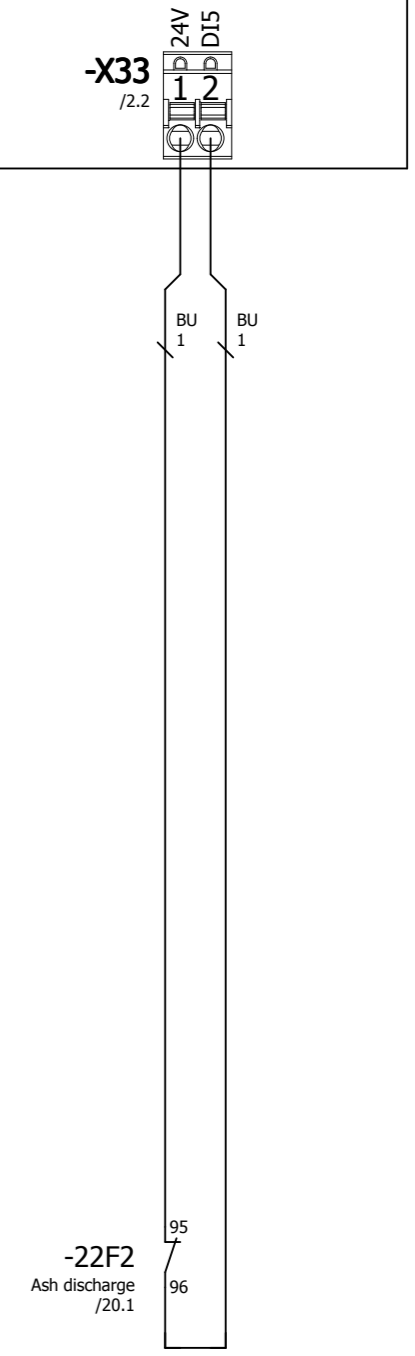
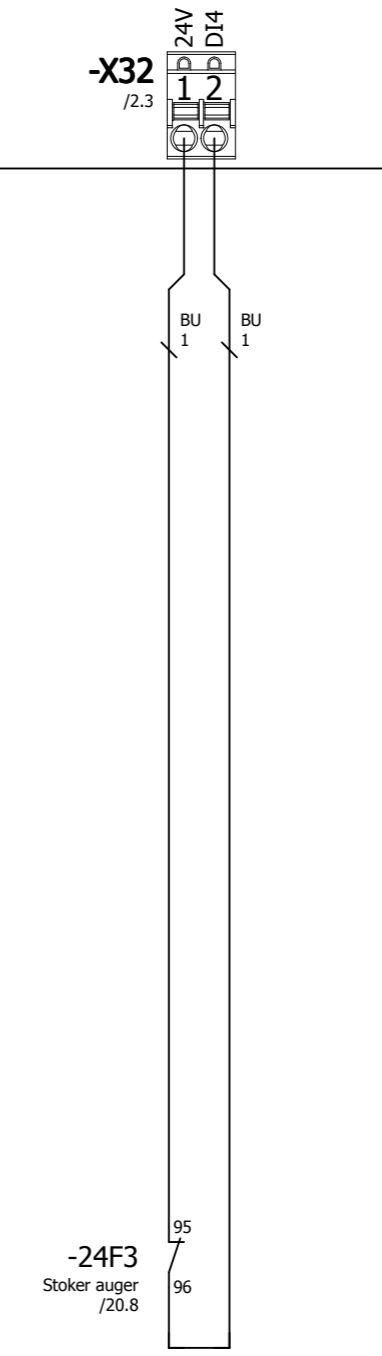
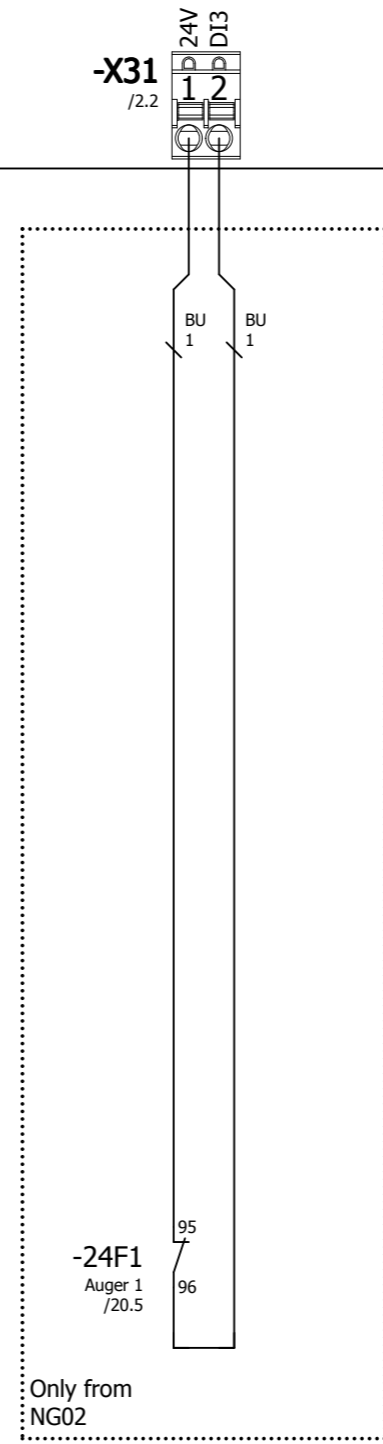
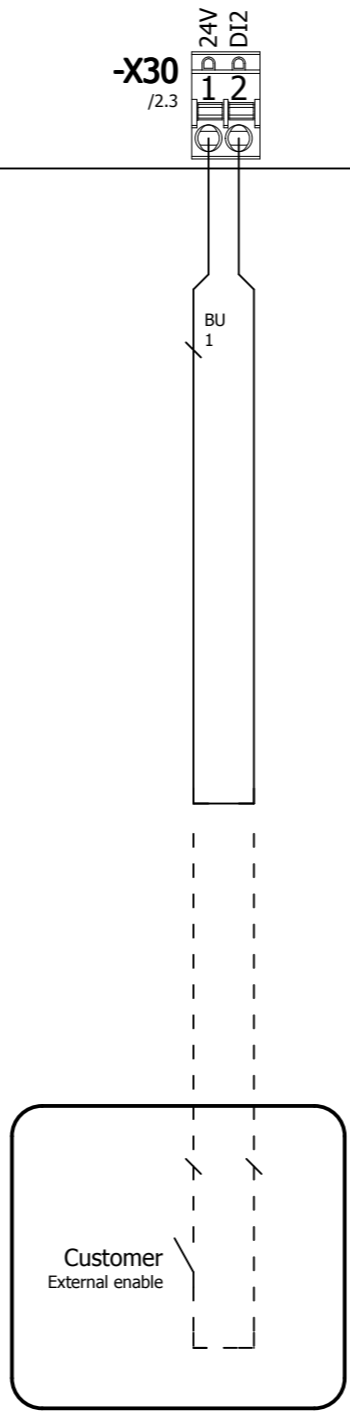
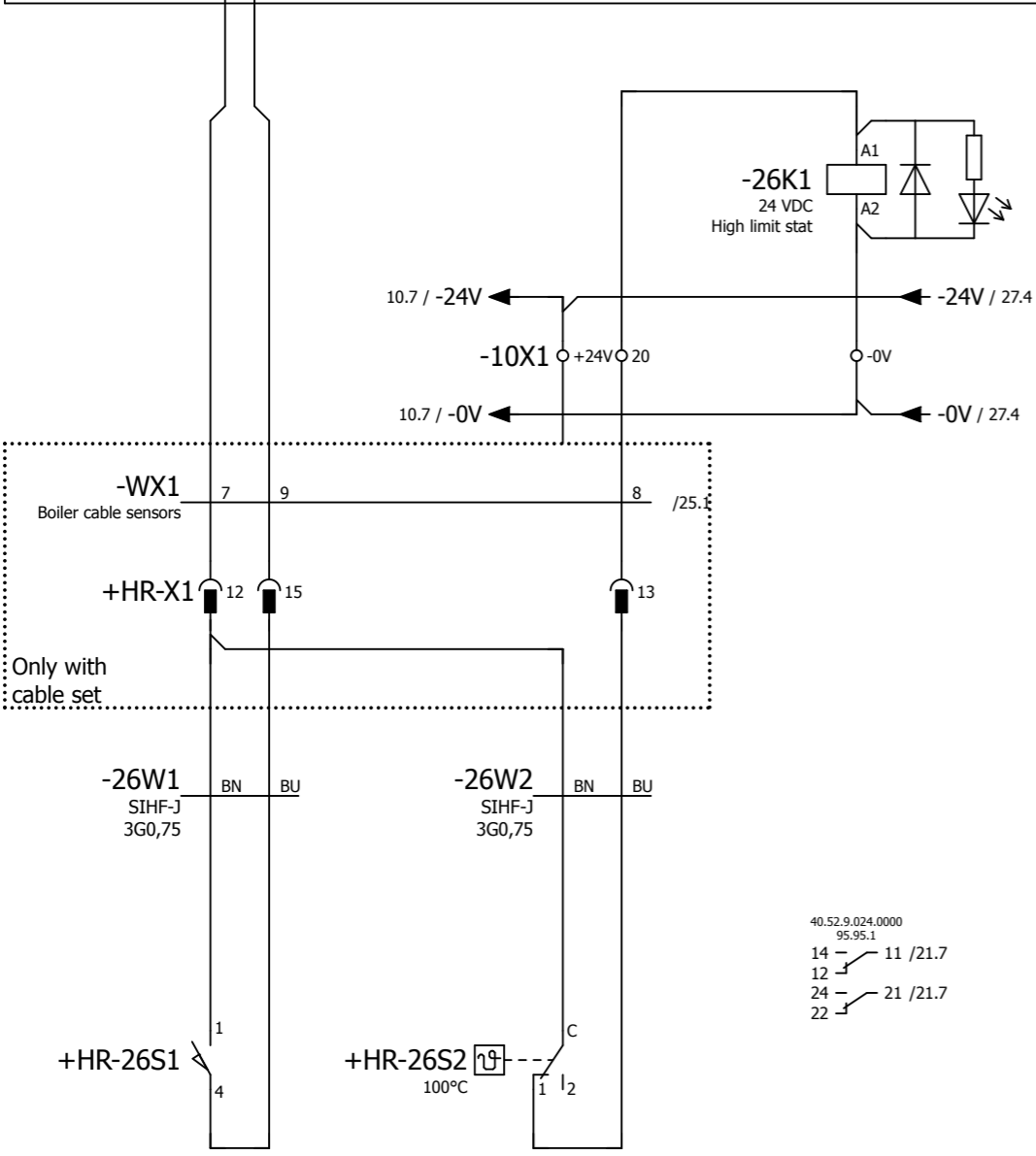
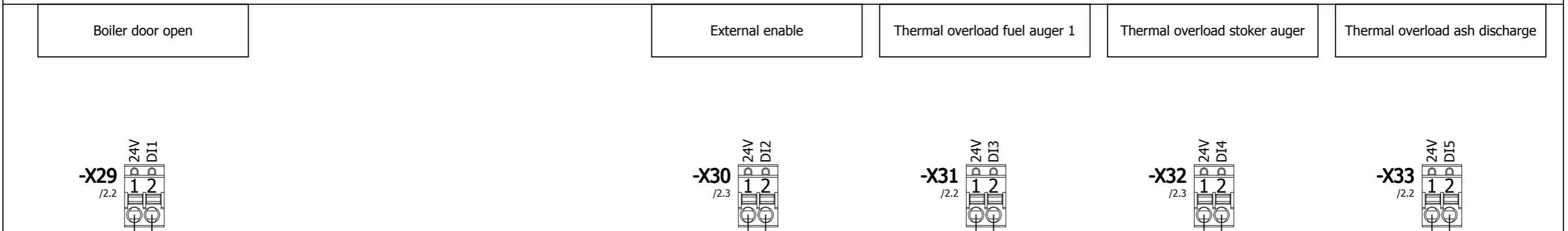

Boiler door High limit stat External enable Terminal thermal overload fuel auger 1 Terminal thermal overload stoker auger Terminal thermal overload ash discharge

-A2 /2.2 **SIGMATEK HZS 522 Power unit**

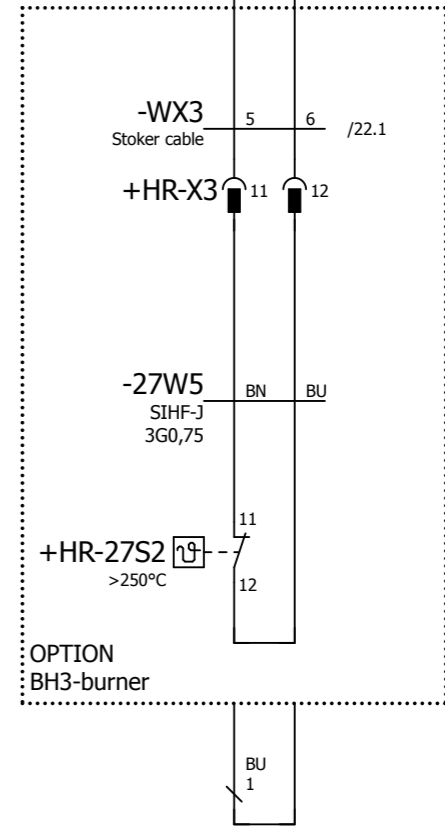
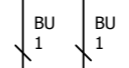
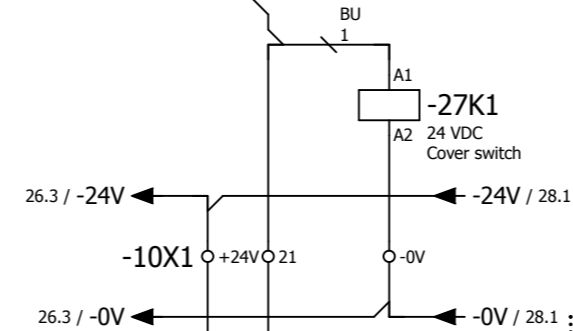
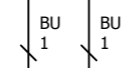
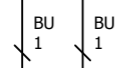
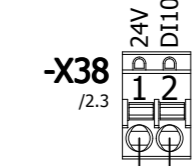
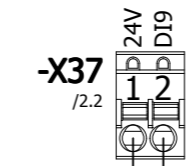
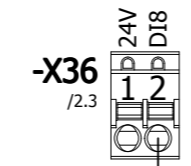
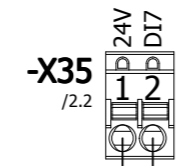
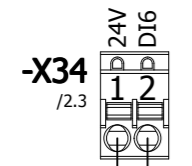
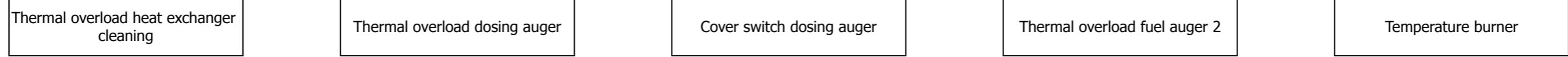

-22F3
Heat exchanger cleaning
/20.2

-24F2
Dosing auger
/20.6

+HR-27S1

-22F4
Auger 2
/20.4

- 55.34.9.024.0090
- 14 - 11 /24.7
- 12 -
- 24 - 21 /24.6
- 22 -
- 34 - 31 /24.5
- 32 -
- 44 - 41 /22.7
- 42 -

Only NG03

Terminal thermal overload heat exchanger cleaning

Terminal thermal overload dosing auger

Cover switch dosing auger

Terminal thermal overload fuel auger 2

Terminal thermal overload Klixon

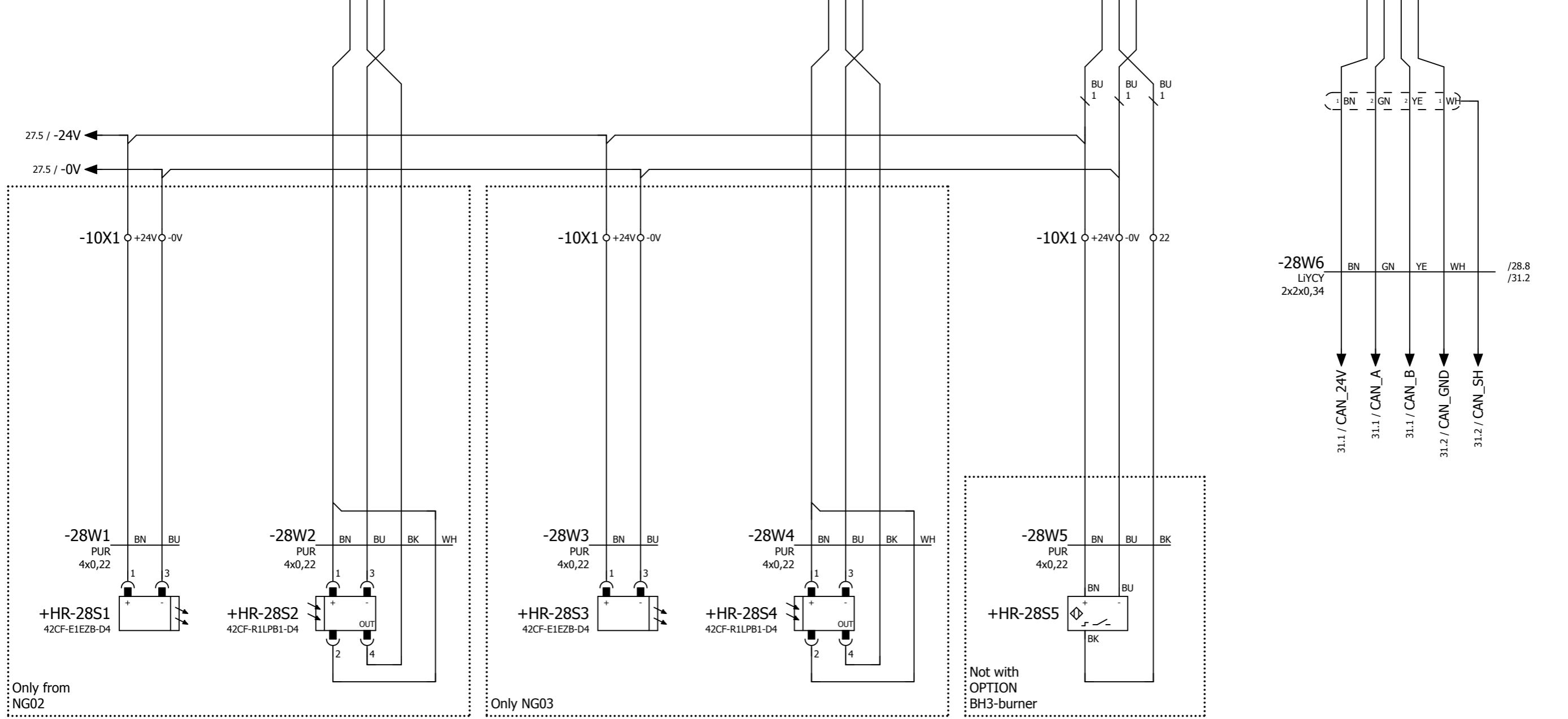
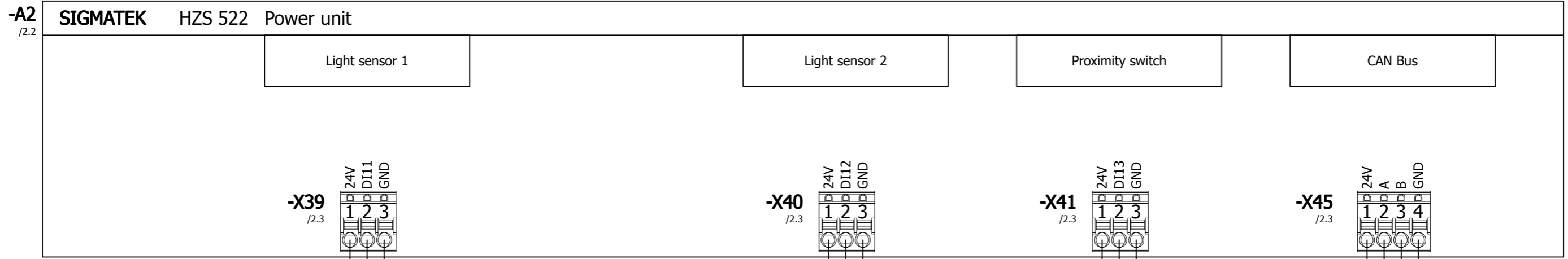

Light sensor transmitter auger 1

Light sensor. Receiver LS auger 1

Light sensor transmitter auger 2

Light sensor. Receiver LS auger 2

Proximity switch stoker auger

CAN Bus

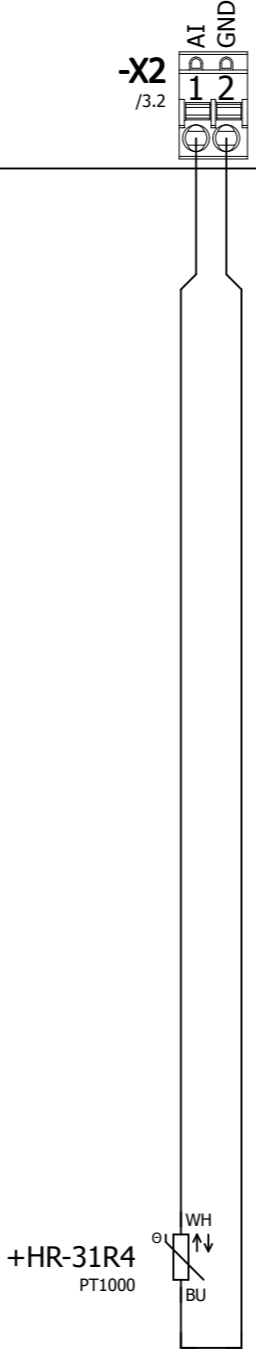
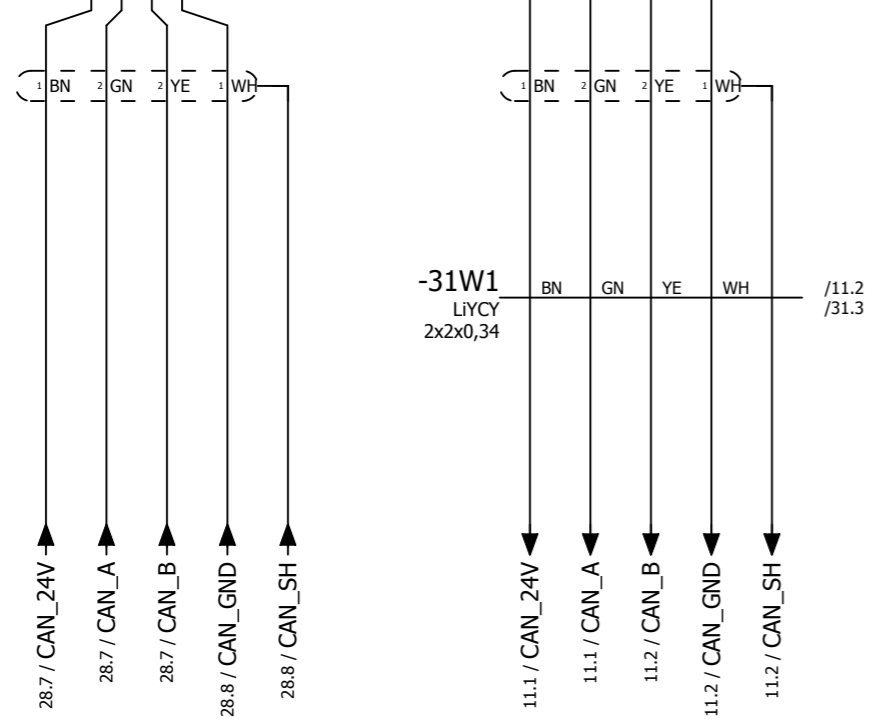
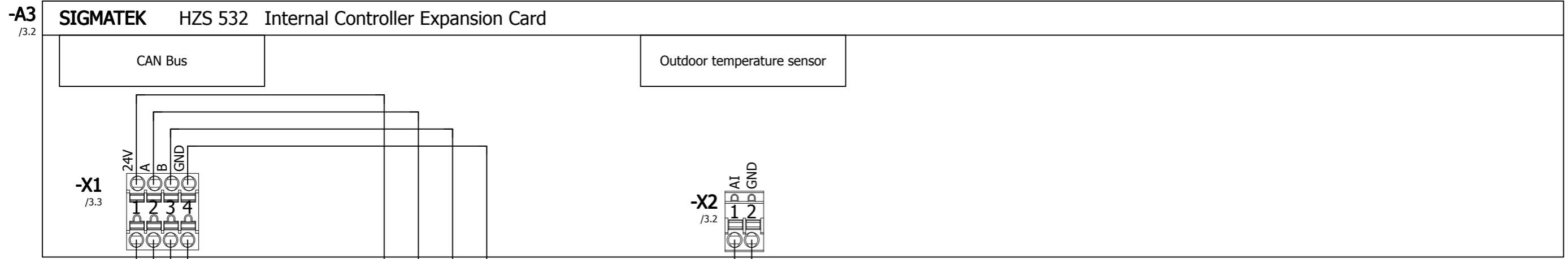

CAN Bus

Outdoor temp. sensor

Modification	Date	Name	Date	21.12.2011
			Ed.	waw
			Appr	
			Original	

GILLES Gilles Energie u. Umwelttechnik
 Koaserbauerstraße 16
 A - 4810 Gmunden
 Tel.: (+43) 7612 / 73 76 0 - 0

Standard
 Woodchips / Pellets Heating System

Internal Controller Expansion Card

HPK-RA 15-160

-A4 /3.2 **SIGMATEK HZS 534 Internal Buffer/Boiler Module**

230V Mains	230V Mains extension	Fast heating module	Charging pump	Temp. sensor top	Temp. sensor bottom	Temp. sensor middle
------------	----------------------	---------------------	---------------	------------------	---------------------	---------------------

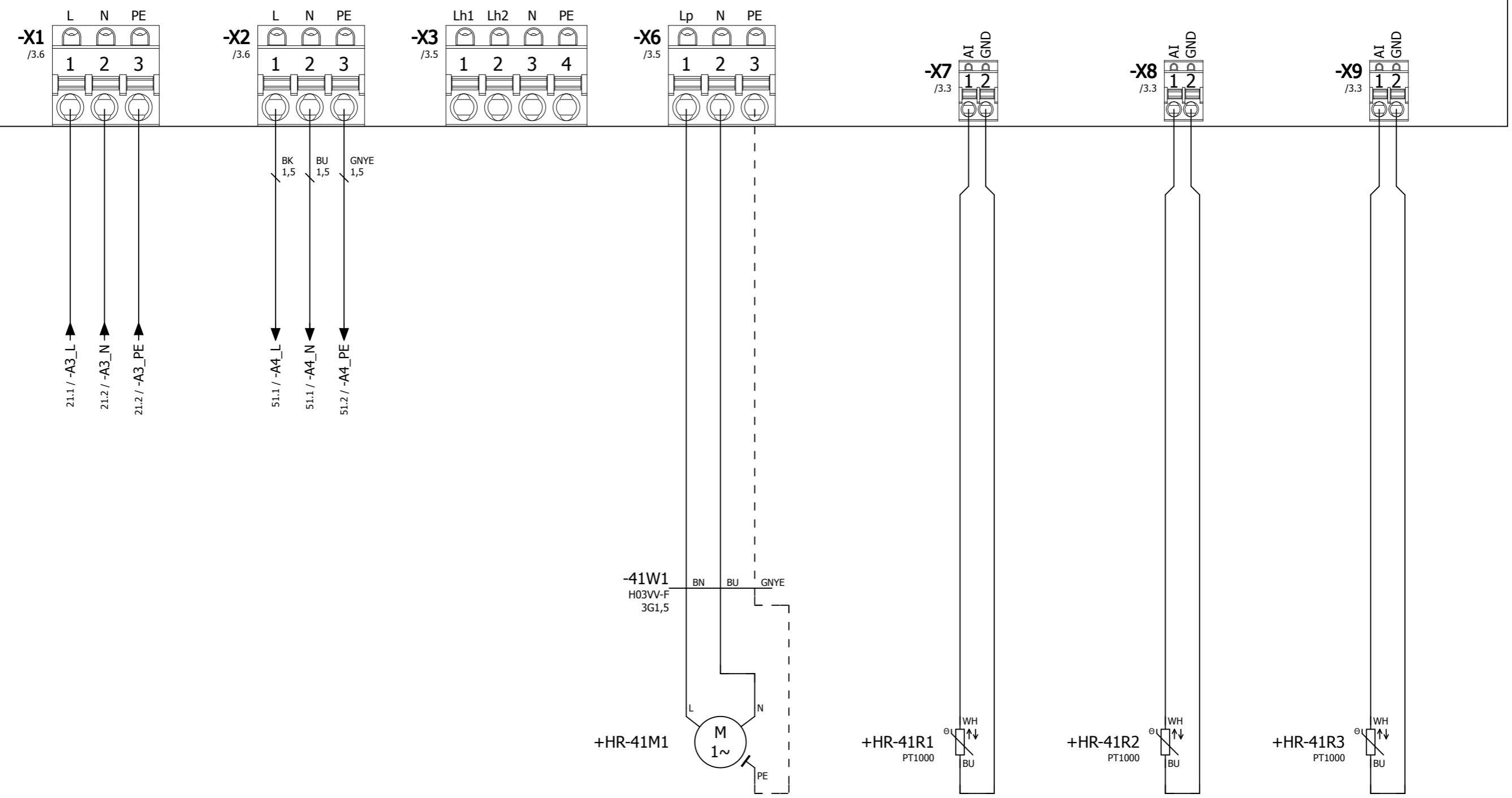

Charging pump Temp. sensor top Temp. sensor bottom Temp. sensor middle

-A5 SIGMATEK HZS 534 Internal Buffer/Boiler Module

230V Mains	230V Mains extension	Fast heating module	Charging pump	Temp. sensor top	Temp. sensor bottom	Temp. sensor middle
------------	----------------------	---------------------	---------------	------------------	---------------------	---------------------

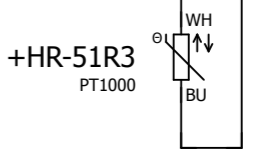
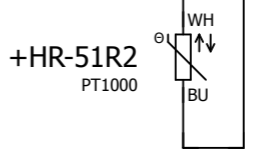
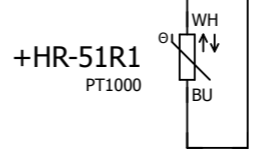
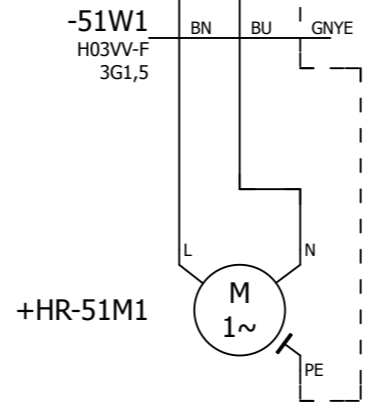
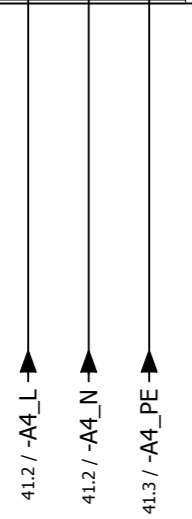
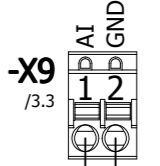
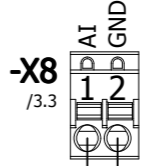
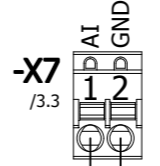
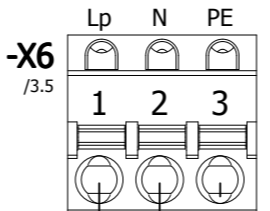
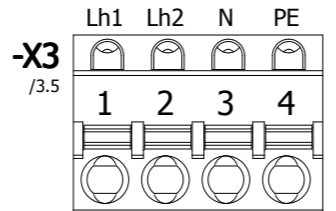
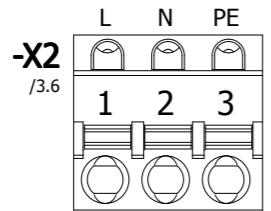
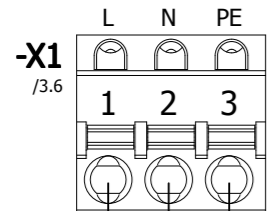

Charging pump Temp. sensor top Temp. sensor bottom Temp. sensor middle

Modification	Date	Name	Date	21.12.2011
			Ed.	waw
			Appr	
			Original	

GILLES Gilles Energie u. Umwelttechnik
 Koaserbauerstraße 16
 A - 4810 Gmunden
 Tel.: (+43) 7612 / 73 76 0 - 0

Standard
 Woodchips / Pellets Heating System

Internal Buffer/Boiler Module

HPK-RA 15-160

Pin-connection diagram

Gilles_STAP_01
21.12.2011 waw

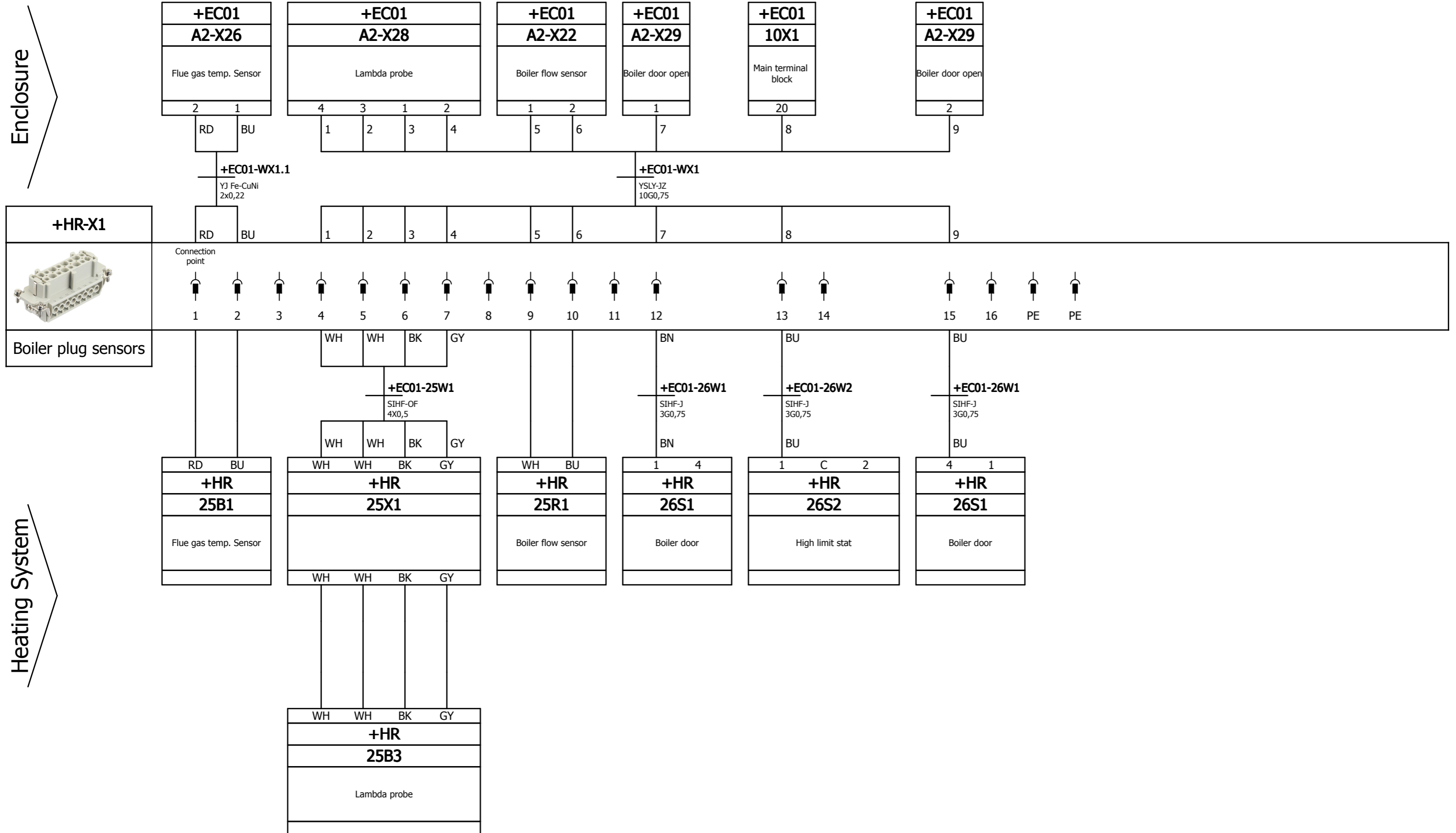

Enclosure

Heating System

=SLP+EC01/51

Modification	Date	Name	Date	21.12.2011
			Ed.	waw
			Appr	
			Original	

Gilles Energie u. Umwelttechnik
 Koaserbauerstraße 16
 A - 4810 Gmunden
 Tel.: (+43) 7612 / 73 76 0 - 0

Standard
 Woodchips / Pellets Heating System

Plug wiring diagram +HR-X1

HPK-RA 15-160

Pin-connection diagram

Gilles_STAP_01
21.12.2011 waw

Enclosure

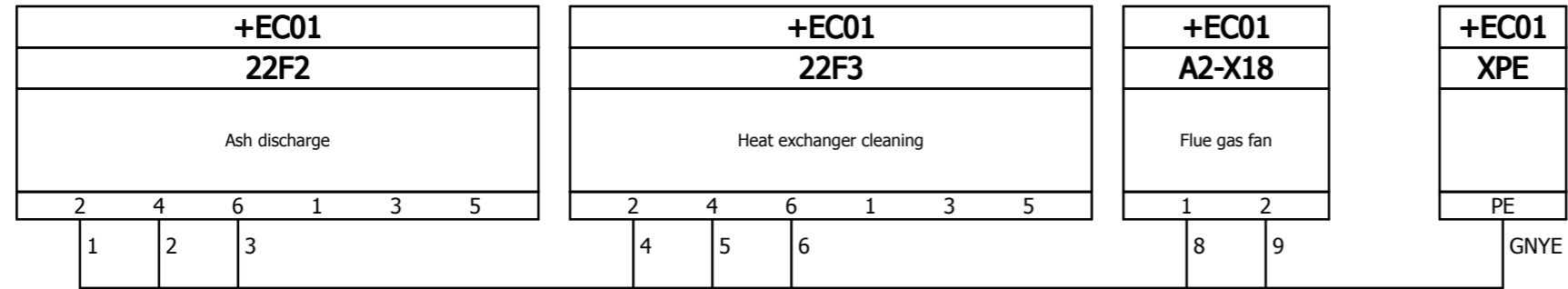

+EC01-WX2
YSLY-JZ
10G1,5

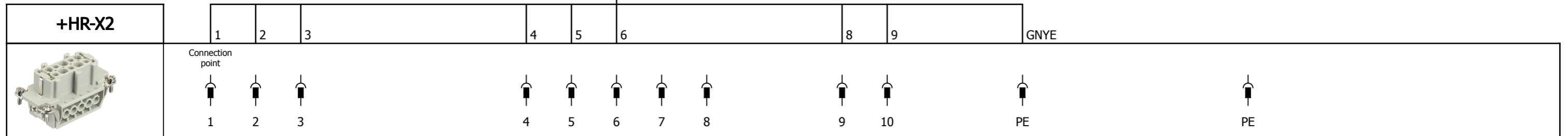

Boiler plug motors

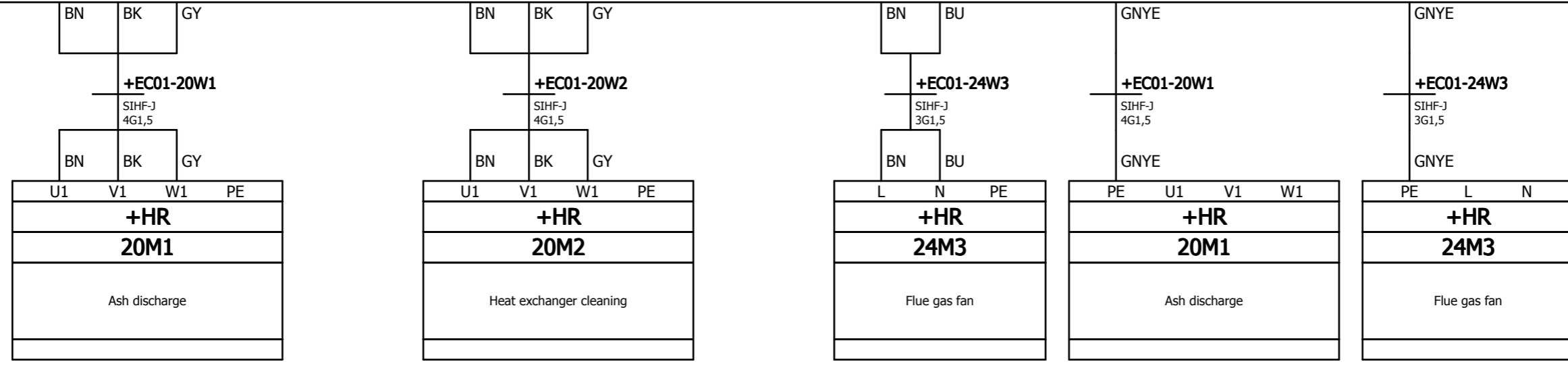

Heating System

Date	21.12.2011
Ed.	waw
Appr	
Original	
Modification	Date
	Name

GILLES Energie u. Umwelttechnik
Koaserbauerstraße 16
A - 4810 Gmunden
Tel.: (+43) 7612 / 73 76 0 - 0

Standard
Woodchips / Pellets Heating System

Plug wiring diagram +HR-X2

HPK-RA 15-160

Pin-connection diagram

Gilles_STAP_01
21.12.2011 waw

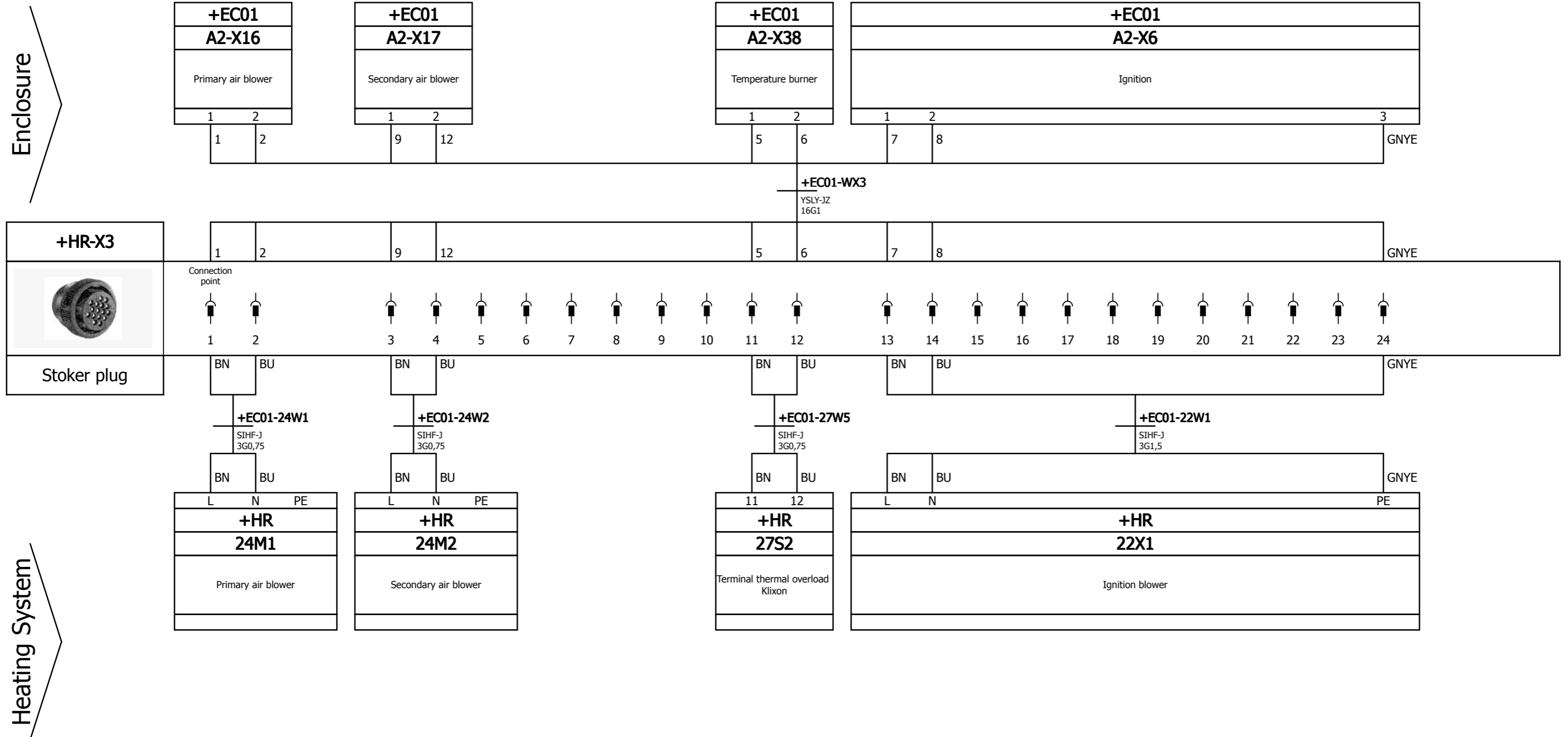

2

4

Date	21.12.2011
Ed.	waw
Appr	
Original	
Modification	Date
	Name

GILLES Energie u. Umwelttechnik
 Koaserbauerstraße 16
 A - 4810 Gmunden
 Tel.: (+43) 7612 / 73 76 0 - 0

Standard
 Woodchips / Pellets Heating System

Plug wiring diagram +HR-X3

HPK-RA 15-160

Pin-connection diagram

Gilles_STAP_01
21.12.2011 waw

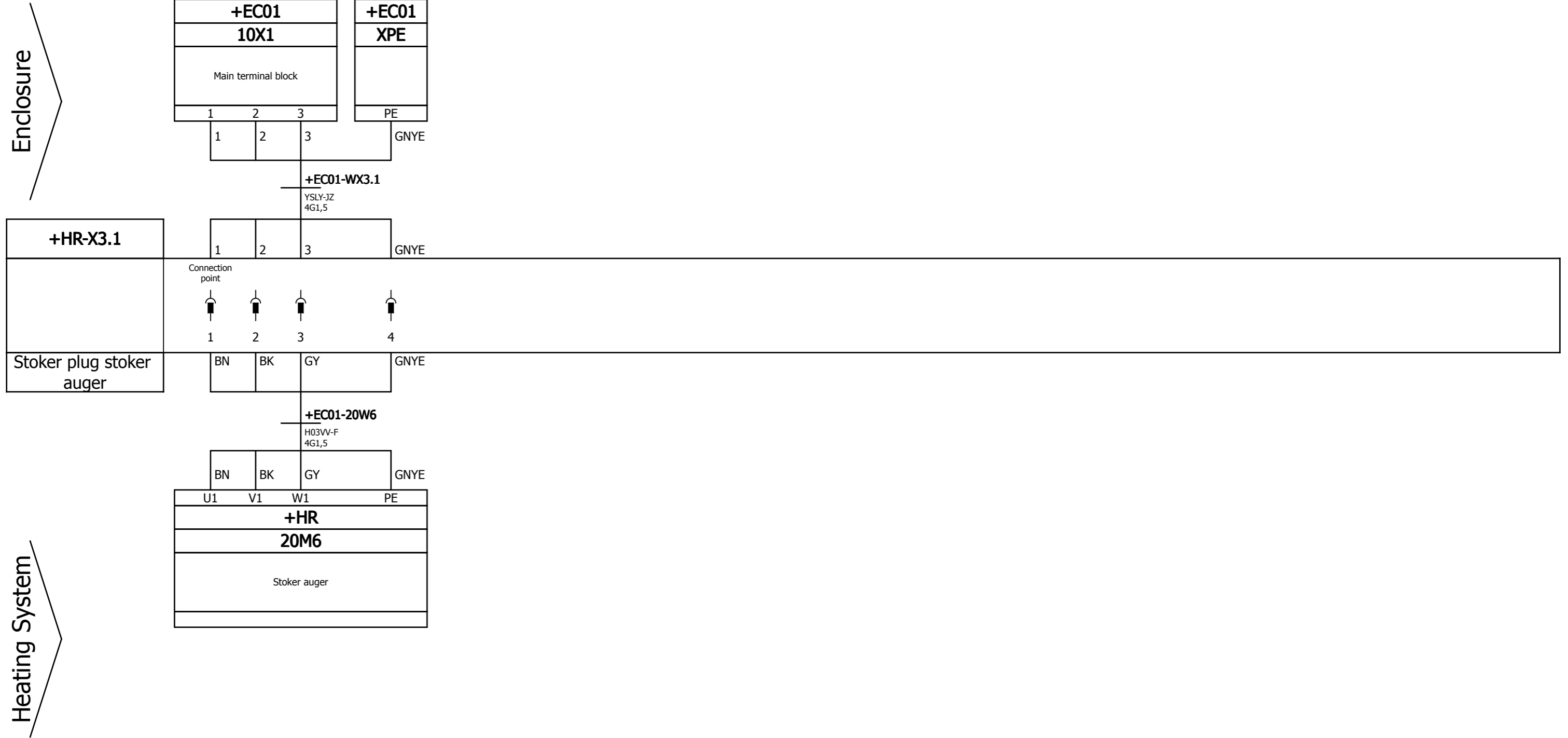

3

Date	21.12.2011
Ed.	waw
Appr	
Original	
Modification	Date
	Name

Gilles Energie u. Umwelttechnik
 Koaserbauerstraße 16
 A - 4810 Gmunden
 Tel.: (+43) 7612 / 73 76 0 - 0

Standard
 Woodchips / Pellets Heating System

Plug wiring diagram +HR-X3.1

HPK-RA 15-160