



GILLES Energie und Umwelttechnik GmbH & Co KG

Koaserbauerstraße 16
A - 4810 Gmunden
Tel.: (+43) 7612 / 73 76 0 - 0
office@gilles.at

Project description Woodchips / Pellets Heating System
Type HPK-RA 15-160
Job number
Software version
Hardware version GT17.1112.XXXX - GT17.1132.XXXX

Kesselserie 8, 2, 3, 10, 4

Site ref. Standard

Nya skåpet från 11-2015

Power supply 400Vac/50Hz, 3Ph+N
Max. pre-fuse 16 A
Input cable 5x2,5mm²

GILLES
Touch

Project name HPK_GT17.1131.X6XX_V3.0

Created on 22.10.2015

Edit date 19.11.2015

By (Abbreviation) krj

Number of pages 32

			Date	19.11.2015	 Gilles Energie u. Umwelttechnik Koaserbauerstraße 16 A - 4810 Gmunden Tel.: (+43) 7612 / 73 76 0 - 0	Standard	Cover sheet	= ALG General +	Page	1
		Ed.	krj							
Modification	Date	Name	Appr Original							
						Woodchips / Pellets Heating System	HPK-RA 15-160			

Table of contents

Gilles_IHV_01

Plant	Mounting location	Page	Page description	Date	Edited by
=ALG General		1	Cover sheet	19.11.2015	krj
		2	Table of contents	19.11.2015	krj
		2.a	Table of contents	19.11.2015	krj
		3	General informations	22.10.2015	krj
=SLP Wiring diagram	+EC01 Switch cabinet	1	HZS 771 - Display / CPU	22.10.2015	krj
	+EC01 Switch cabinet	2	HZS 5211 - Leistungsteil	22.10.2015	krj
	+EC01 Switch cabinet	10	Power supply	22.10.2015	krj
	+EC01 Switch cabinet	11	Display / CPU	22.10.2015	krj
	+EC01 Switch cabinet	12	Leistungsteil Schnecke 2	29.10.2015	krj
	+EC01 Switch cabinet	13	Leistungsteil Einschubschnecke	22.10.2015	krj
	+EC01 Switch cabinet	14	Leistungsteil Dosierschnecke	29.10.2015	krj
	+EC01 Switch cabinet	15	Leistungsteil Schnecke 1	29.10.2015	krj
	+EC01 Switch cabinet	21	Power unit X1 - X6	19.11.2015	krj
	+EC01 Switch cabinet	22	Power unit X7 - X12	19.11.2015	krj
	+EC01 Switch cabinet	23	Power unit X13 - X18	19.11.2015	krj
	+EC01 Switch cabinet	24	Power unit X19 - X24	22.10.2015	krj
	+EC01 Switch cabinet	25	Power unit X25 - X30	22.10.2015	krj
	+EC01 Switch cabinet	26	Power unit X31 - X35	22.10.2015	krj
	+EC01 Switch cabinet	27	Power unit X36 - X39	22.10.2015	krj
	+EC01 Switch cabinet	28	Power unit X40 - X45	22.10.2015	krj
+EC01 Switch cabinet	29	Power unit X46 - X51	22.10.2015	krj	
+EC01 Switch cabinet	30	Power unit X52 - X54	13.11.2015	krj	
=STAP Pin-connection diagram		1	Pin-connection diagram +HR-X1	19.11.2015	krj
		2	Pin-connection diagram +HR-X2	19.11.2015	krj
=BML Device tag list		1	Device tag list	19.11.2015	krj
		2	Device tag list	19.11.2015	krj
		3	Device tag list	19.11.2015	krj
		4	Device tag list	19.11.2015	krj

1

2.a

Table of contents

Gilles_IHV_01

Plant	Mounting location	Page	Page description	Date	Edited by
=BML	Device tag list	5	Device tag list	19.11.2015	krj
		6	Device tag list	19.11.2015	krj
		7	Device tag list	19.11.2015	krj
		8	Device tag list	19.11.2015	krj

2

3

			Date	19.11.2015	 Gilles Energie u. Umwelttechnik Koaserbauerstraße 16 A - 4810 Gmunden Tel.: (+43) 7612 / 73 76 0 - 0	Standard	Table of contents	HPK-RA 15-160	= ALG General
		Ed.	krj	+					
Modification	Date	Name	Appr Original	Page					2.a

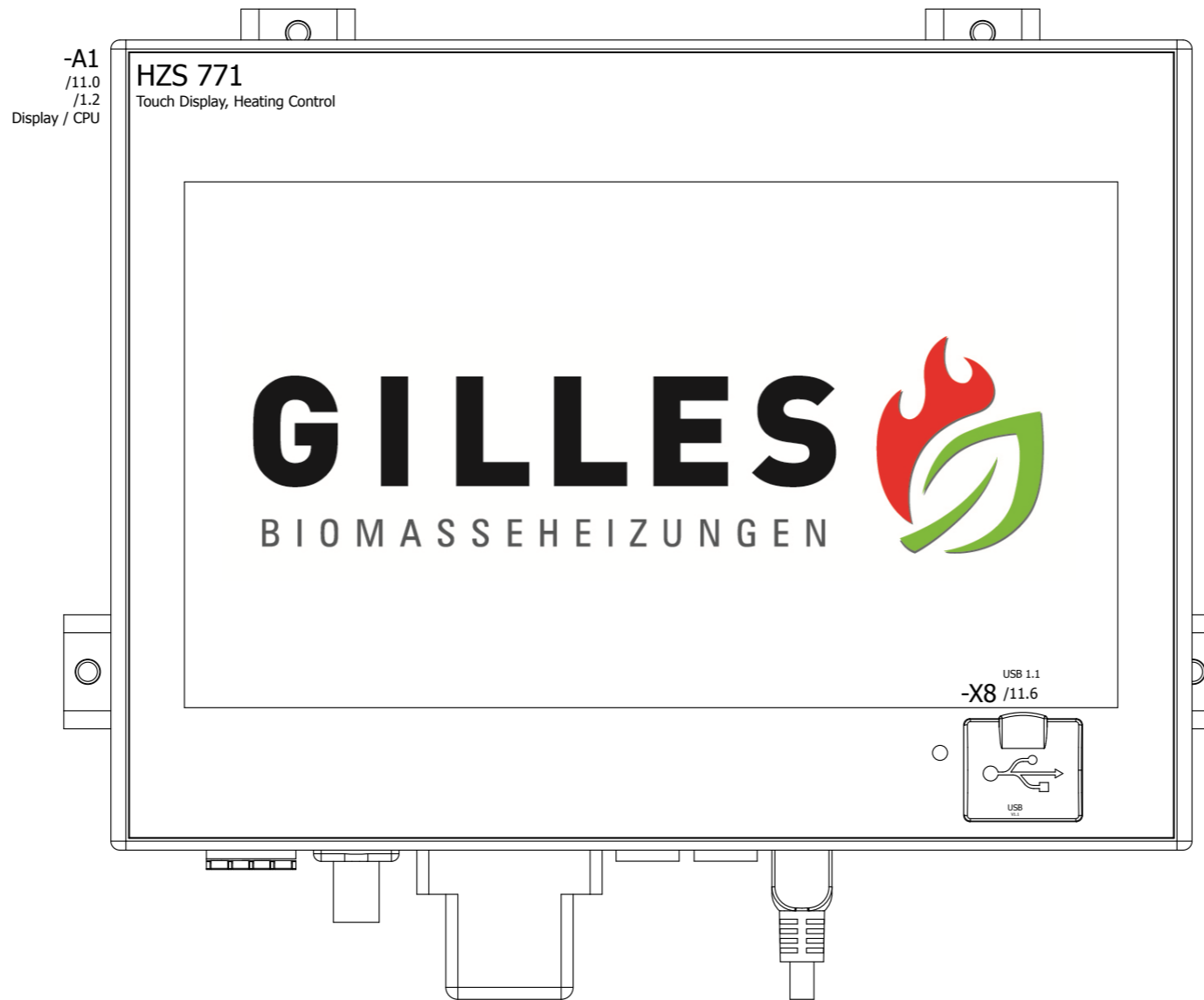

- X1 Power supply
- X2 Ethernet
- X3 RS 232
- X4 CAN Bus
- X6 Mini USB type B
- X8 USB 1.1

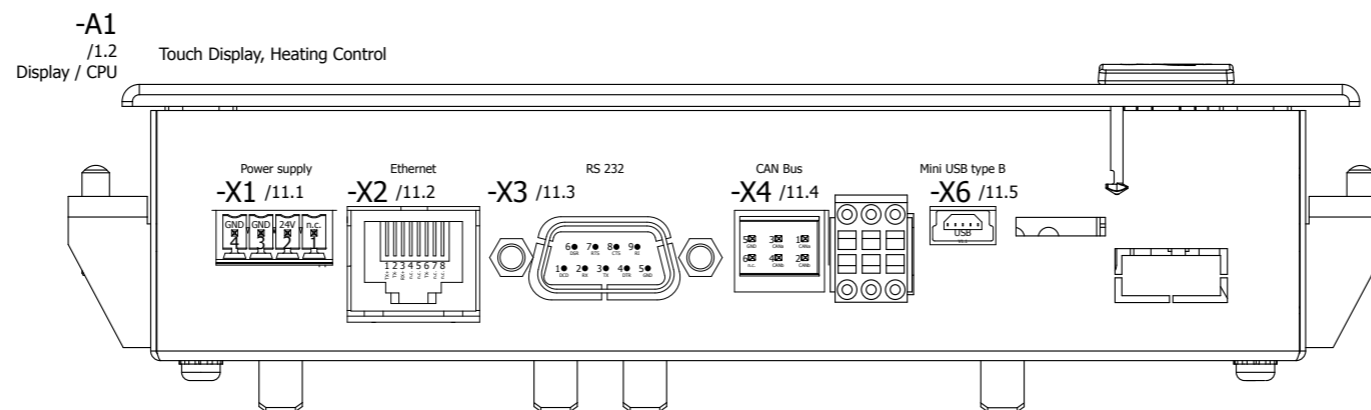

=ALG+/3

Modification	Date	Name	Appr	Date	22.10.2015
			Original	Ed.	krj

GILLES Energie u. Umwelttechnik
 Koaserbauerstraße 16
 A - 4810 Gmunden
 Tel.: (+43) 7612 / 73 76 0 - 0

Standard
 Woodchips / Pellets Heating System

HZS 771 - Display / CPU

HPK-RA 15-160

= SLP Wiring diagram
 + EC01 Switch cabinet

Page

-A2
/21.0
/22.0
/23.0
/24.0
/25.0
/26.0
/27.0
/28.0
/29.0
/30.0
Heizungssteuerung

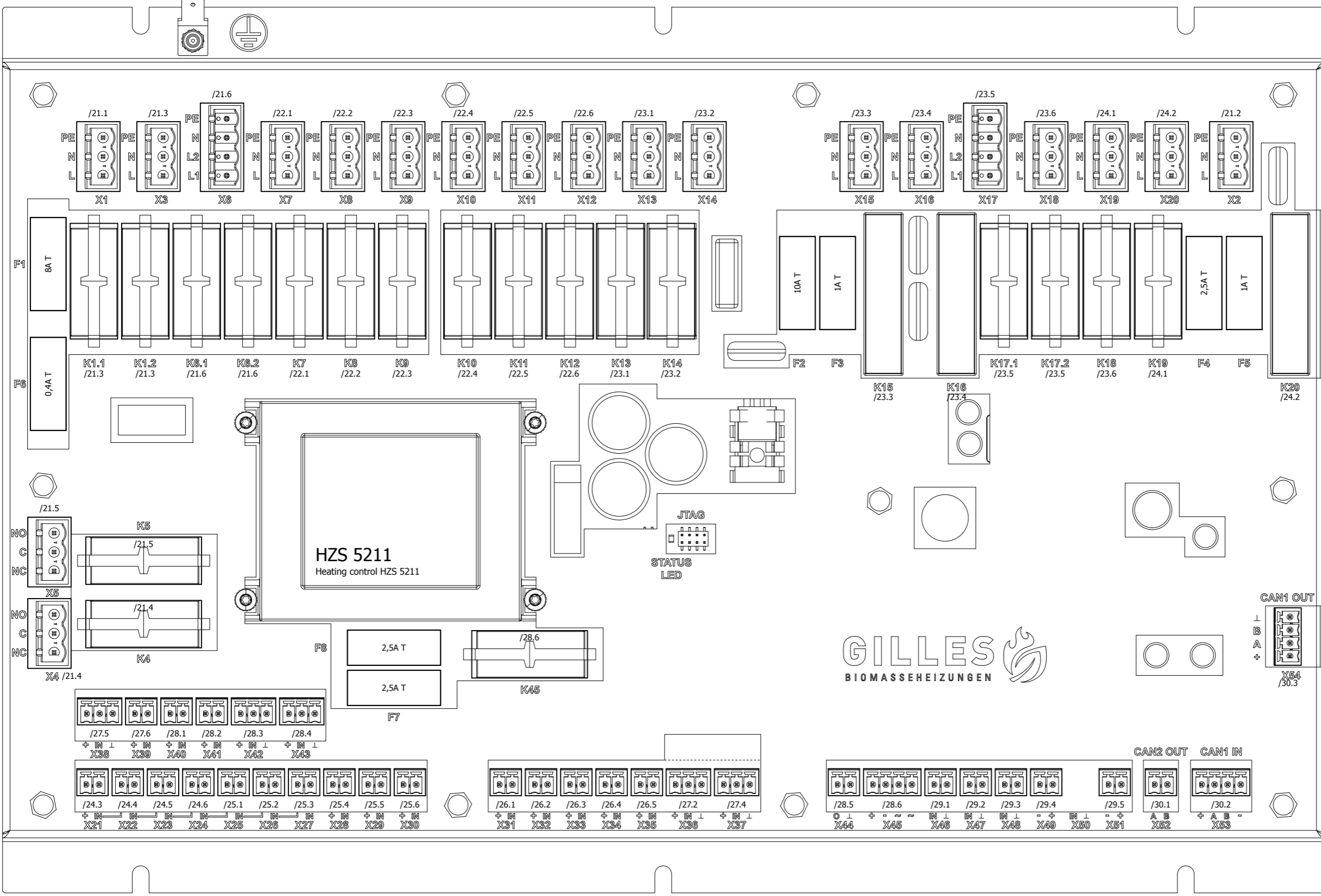

- X1 230V Mains
- X2 230V Mains extension
- X3 230V mains extension
- X4 Critical alarm
- X5 Signal contact configurable
- X6 Ignition blower
- X7 Auger 2
- X8 Ash discharge
- X9 Heat exchanger cleaning
- X10 Stokerauger forward
- X11 Stokerauger backwards
- X12 Dosing auger
- X13 Auger 1
- X14 Suction cup
- X15 Primary air blower
- X16 Secondary air blower
- X17 3 way diverting valve
- X18 Bypass pump
- X19 Fuel store temp. alarm
- X20 Flue gas fan
- X21 Emergency stop
- X22 High limit stat
- X23 Coverswitch
- X24 Thermal overload stoker auger
- X25 Thermal overload dosing auger
- X26 Thermal overload fuel auger 1
- X27 Thermal overload fuel auger 2
- X28 Boiler door
- X29 External enable
- X30 Customer contact
- X31 Spare
- X32 Spare
- X33 Spare
- X34 Thermal overload ash discharge
- X35 Thermal overload heat exchanger cleaning
- X36 Light Sensor Auger 1
- X37 Light Sensor Auger 2
- X38 Proximity switch stoker auger
- X39 Temperature burner
- X40 Key switch fuel store filling
- X41 Fault bypass pump
- X42 Speedrecognition Fluegasfan
- X43 Speedrecognition Stokerauger
- X44 required Speed Fluegas-Fan
- X45 Lambda probe
- X46 Boiler flow sensor
- X47 Return temp. sensor
- X48 Fuel store temp. sensor
- X49 Flue gas temp. Sensor

- X51 Combustion chamber temp. sensor
- X52 CAN2 OUT
- X53 CAN1 IN
- X54 CAN1 OUT

Date	22.10.2015
Ed.	krj
Appr	
Original	
Modification	Date
	Name

GILLES Energie u. Umwelttechnik
 Koaserbauerstraße 16
 A - 4810 Gmunden
 Tel.: (+43) 7612 / 73 76 0 - 0

Standard
 Woodchips / Pellets Heating System

HZS 5211 - Leistungsteil

HPK-RA 15-160

= SLP Wiring diagram
 + EC01 Switch cabinet
 Page 2

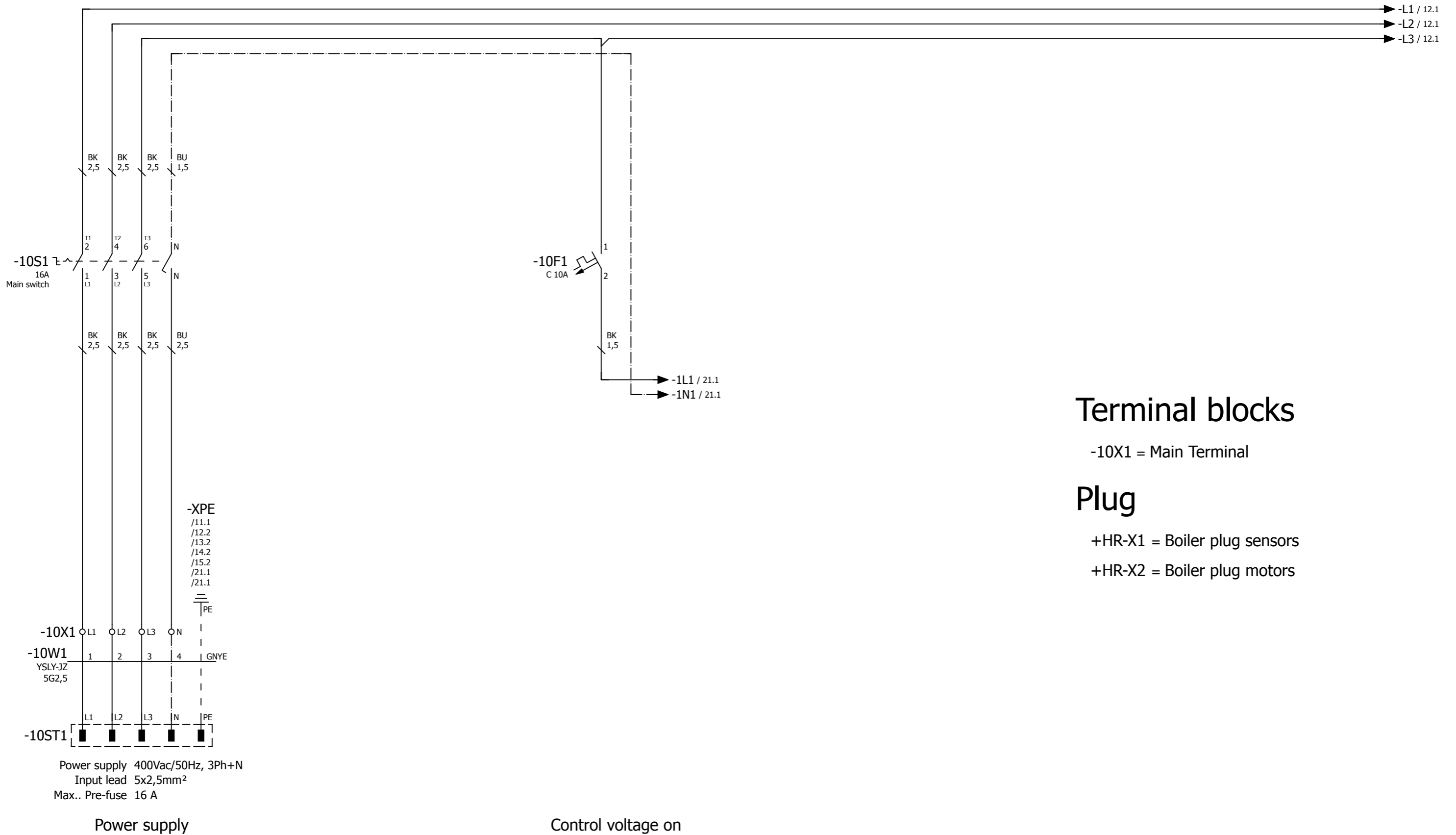

-A1 SIGMATEK HZS 771 Touch Display, Heating Control

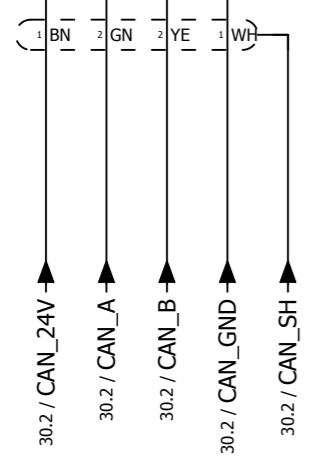
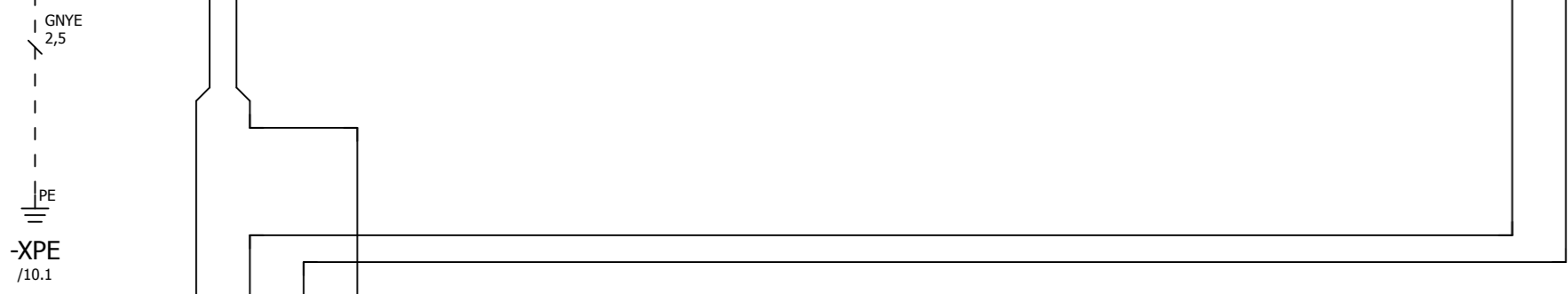
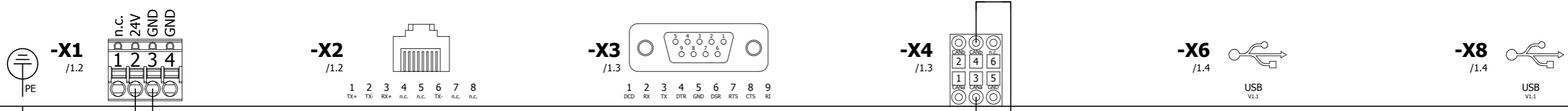
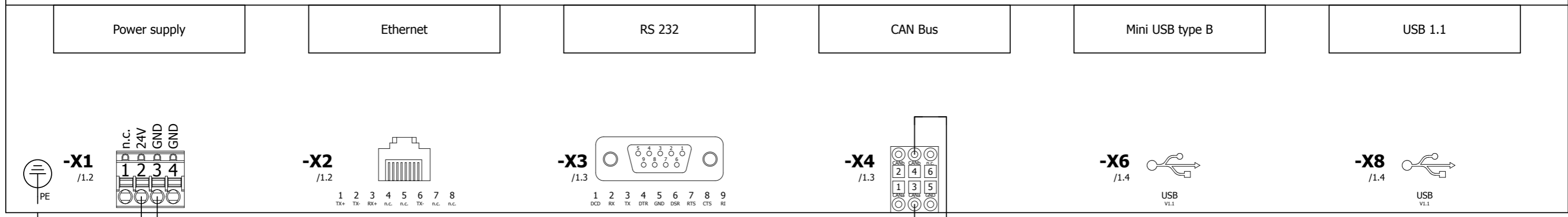

CAN Bus

Modification	Date	Name	Date	22.10.2015	Gilles Energie u. Umwelttechnik Koaserbauerstraße 16 A - 4810 Gmunden Tel.: (+43) 7612 / 73 76 0 - 0	Standard	Woodchips / Pellets Heating System	Display / CPU	HPK-RA 15-160	= SLP Wiring diagram
			Ed.	krj						+ EC01 Switch cabinet
			Appr							Page
			Original							11

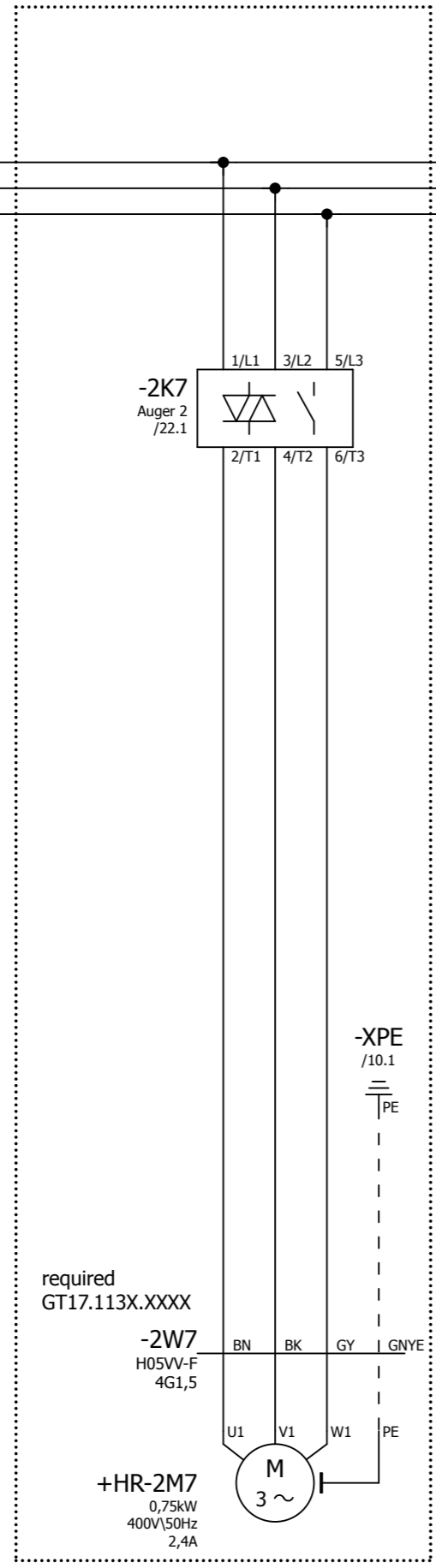
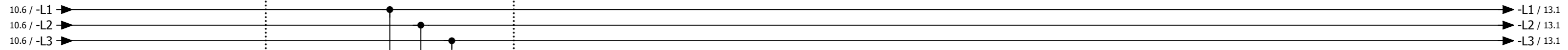

required
GT17.113X.XXXX

-2W7
H05VV-F
4G1,5

+HR-2M7
0,75kW
400V/50Hz
2,4A

Auger 2

2K7

2,4A

PWR

Err

Iadj

ON

Reset

Auger 2

LED																
PWR																
Err																
Iadj																
ON																
Rated current	0,18A	0,25A	0,41A	0,56A	0,71A	0,87A	1,02A	1,17A	1,33A	1,48A	1,63A	1,79A	1,94A	2,09A	2,25A	2,40A
Motor										0,55kW				0,75kW		

2K7

9A

PWR

Err

Iadj

ON

Reset

Auger 2

LED																
PWR																
Err																
Iadj																
ON																
Rated current	1,50A	2,00A	2,50A	3,00A	3,50A	4,00A	4,50A	5,00A	5,50A	6,00A	6,50A	7,00A	7,50A	8,00A	8,50A	9,00A
Motor				1,1kW	1,5kW				2,2kW							4,0kW

Date	29.10.2015
Ed.	krj
Appr	
Original	
Modification	
Date	
Name	

Gilles Energie u. Umwelttechnik
 Koaserbauerstraße 16
 A - 4810 Gmunden
 Tel.: (+43) 7612 / 73 76 0 - 0

Standard
 Woodchips / Pellets Heating System

Leistungsteil Schnecke 2

HPK-RA 15-160

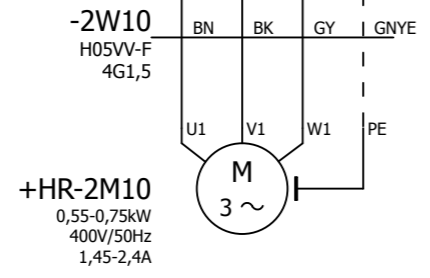
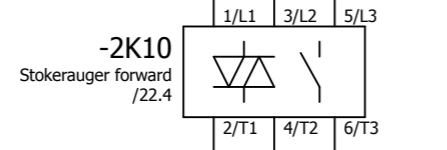
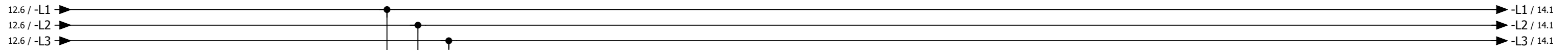

Stokerauger forward

2K10

Stokerauger / Cellwheel																
LED																
PWR																
Err																
L																
R																
Rated current	0,18A	0,25A	0,41A	0,56A	0,71A	0,87A	1,02A	1,17A	1,33A	1,48A	1,63A	1,79A	1,94A	2,09A	2,25A	2,40A
Motor										0,55kW				0,75kW		

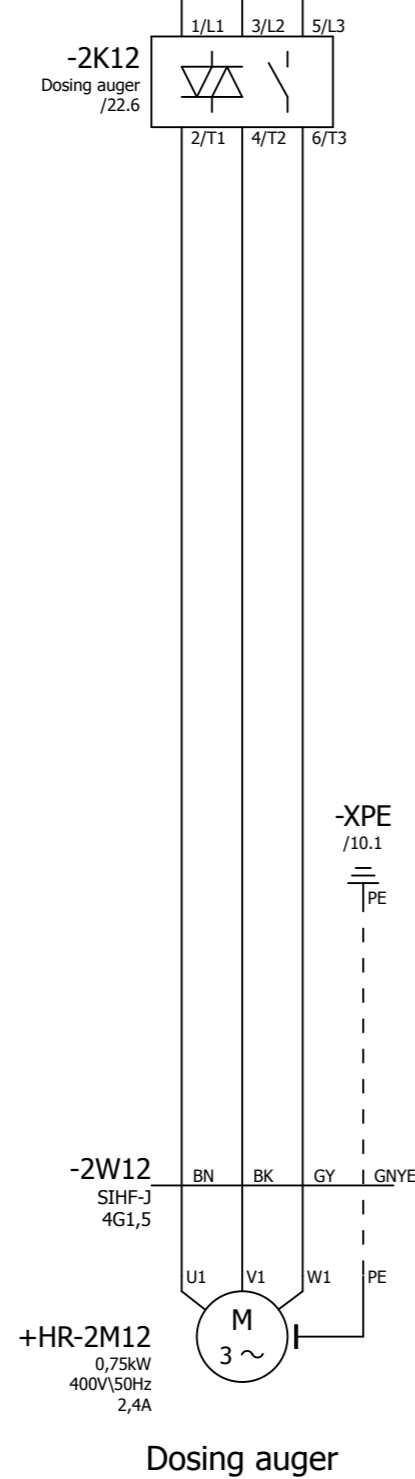
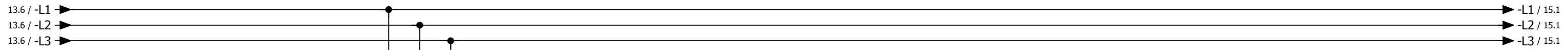

2K12

2,4A

PWR

Err

Iadj

ON

Reset

2K12

9A

PWR

Err

Iadj

ON

Reset

Dosing auger

LED																
PWR																
Err																
Iadj																
ON																
Rated current	0,18A	0,25A	0,41A	0,56A	0,71A	0,87A	1,02A	1,17A	1,33A	1,48A	1,63A	1,79A	1,94A	2,09A	2,25A	2,40A
Motor										0,55kW				0,75kW		

Dosing auger

LED																
PWR																
Err																
Iadj																
ON																
Rated current	1,50A	2,00A	2,50A	3,00A	3,50A	4,00A	4,50A	5,00A	5,50A	6,00A	6,50A	7,00A	7,50A	8,00A	8,50A	9,00A
Motor				1,1kW	1,5kW				2,2kW							4,0kW

Date	29.10.2015
Ed.	krj
Appr	
Original	
Modification	
Date	
Name	

GILLES Energie u. Umwelttechnik
 Koaserbauerstraße 16
 A - 4810 Gmunden
 Tel.: (+43) 7612 / 73 76 0 - 0

Standard
 Woodchips / Pellets Heating System

Leistungsteil Dosierschnecke

HPK-RA 15-160

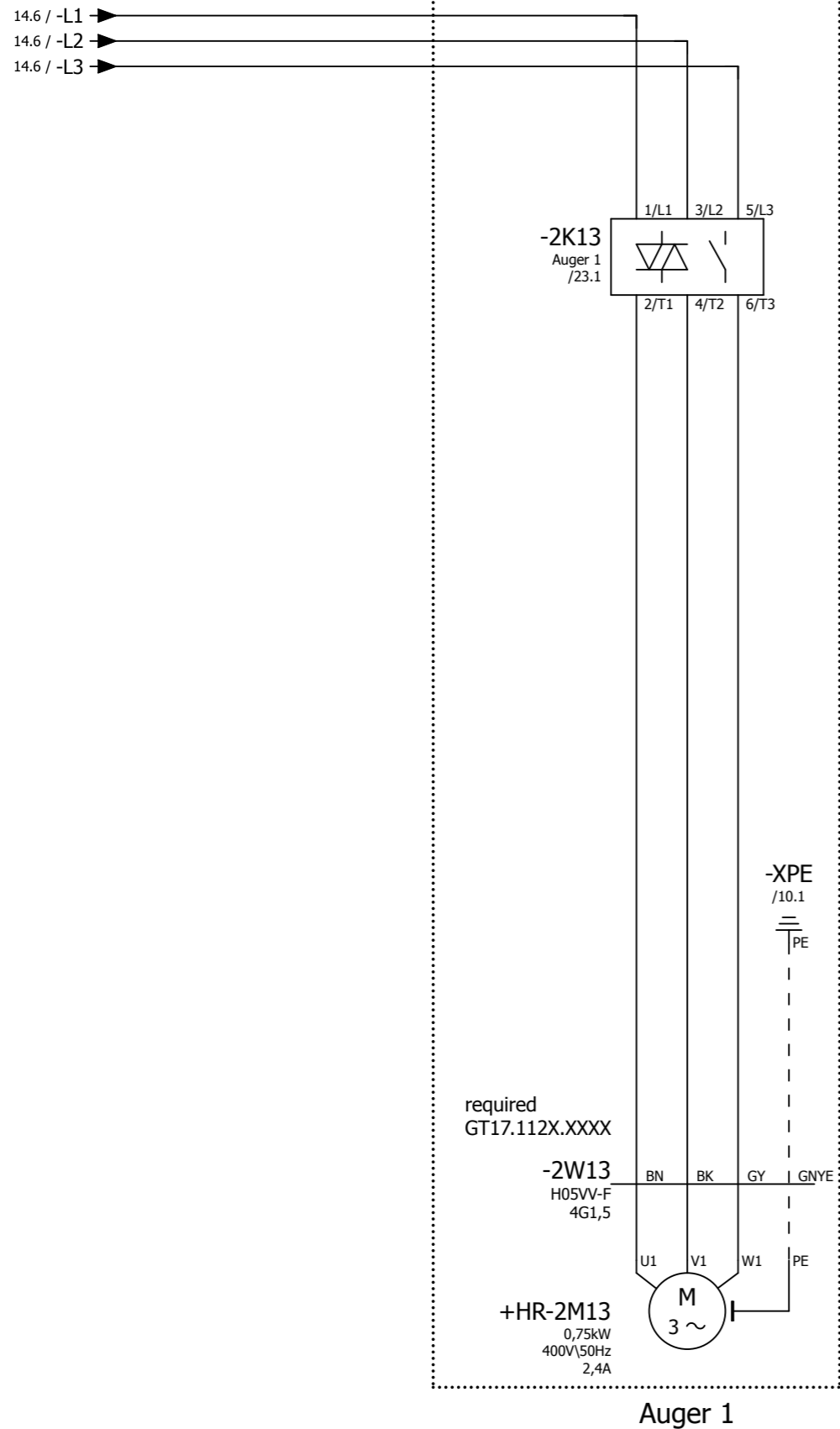

2K13

2,4A

PWR

Err

Iadj

ON

Reset

Auger 1

LED																
PWR																
Err																
Iadj																
ON																
Rated current	0,18A	0,25A	0,41A	0,56A	0,71A	0,87A	1,02A	1,17A	1,33A	1,48A	1,63A	1,79A	1,94A	2,09A	2,25A	2,40A
Motor										0,55kW				0,75kW		

2K13

9A

PWR

Err

Iadj

ON

Reset

Auger 1

LED																
PWR																
Err																
Iadj																
ON																
Rated current	1,50A	2,00A	2,50A	3,00A	3,50A	4,00A	4,50A	5,00A	5,50A	6,00A	6,50A	7,00A	7,50A	8,00A	8,50A	9,00A
Motor				1,1kW	1,5kW				2,2kW							4,0kW

Date	29.10.2015
Ed.	krj
Appr	
Original	
Modification	
Date	
Name	

Gilles Energie u. Umwelttechnik
 Koaserbauerstraße 16
 A - 4810 Gmunden
 Tel.: (+43) 7612 / 73 76 0 - 0

Standard
 Woodchips / Pellets Heating System

Leistungsteil Schnecke 1

HPK-RA 15-160

-A2 SIGMATEK HZS 5211 Heating control HZS 5211

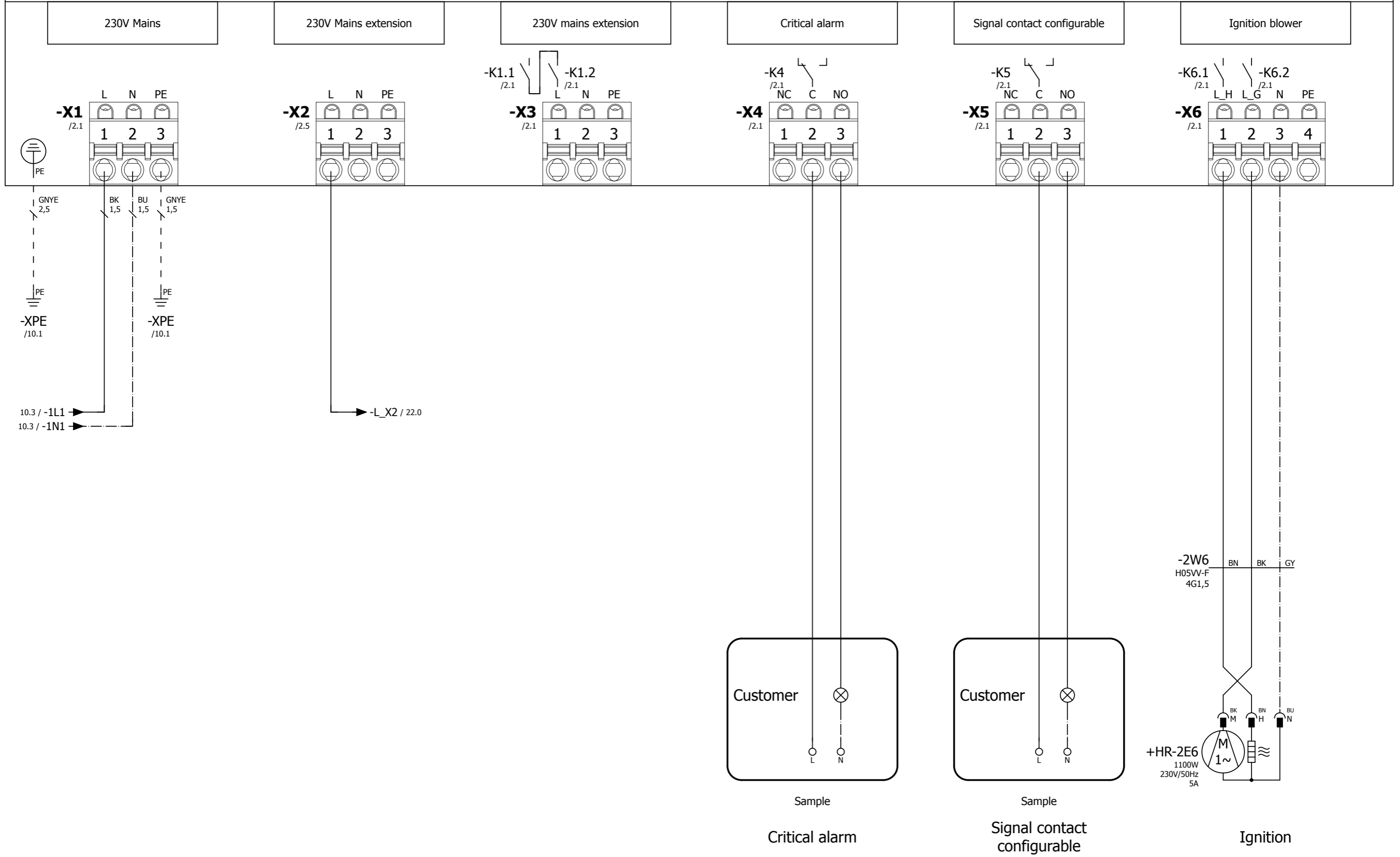

Modification	Date	Name	Date	19.11.2015
			Ed.	krj
			Appr	
			Original	

GILLES Energie u. Umwelttechnik
 Koaserbauerstraße 16
 A - 4810 Gmunden
 Tel.: (+43) 7612 / 73 76 0 - 0

Standard
 Woodchips / Pellets Heating System

Power unit X1 - X6

HPK-RA 15-160

-A2
/2.1

SIGMATEK HZS 5211 Heating control HZS 5211

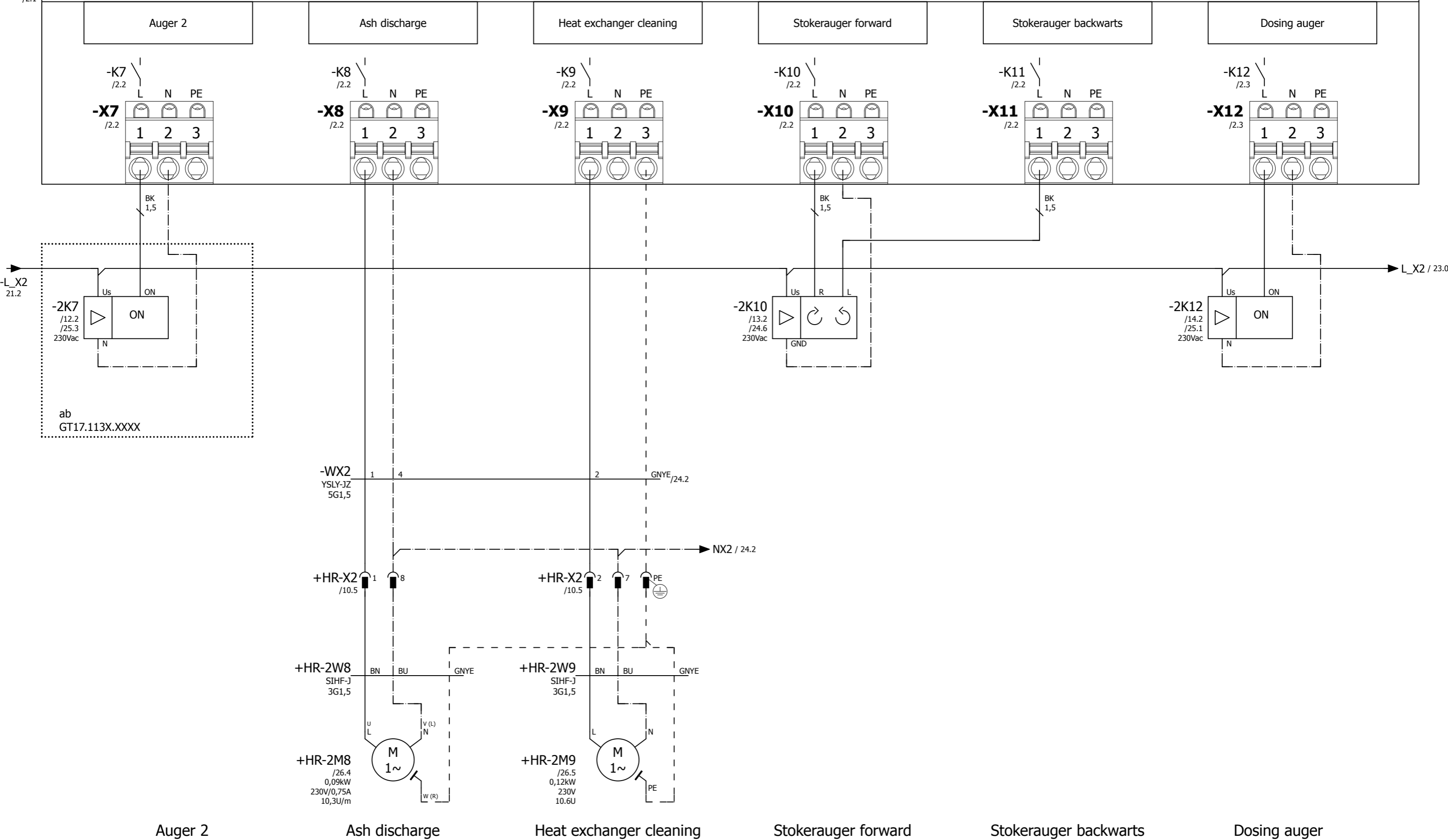

21

23

Date	19.11.2015
Ed.	krj
Appr	
Original	
Modification	Date
	Name

GILLES Energie u. Umwelttechnik
 Koaserbauerstraße 16
 A - 4810 Gmunden
 Tel.: (+43) 7612 / 73 76 0 - 0

Standard
 Woodchips / Pellets Heating System

Power unit X7 - X12

HPK-RA 15-160

= SLP Wiring diagram
 + EC01 Switch cabinet
 Page 22

-A2
/2.1

SIGMATEK HZS 5211 Heating control HZS 5211

Auger 1

Suction cup

Primary air blower

Secondary air blower

3 way diverting valve

Bypass pump

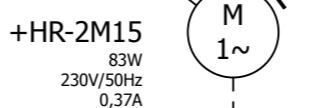
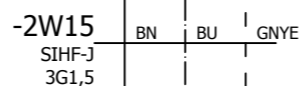
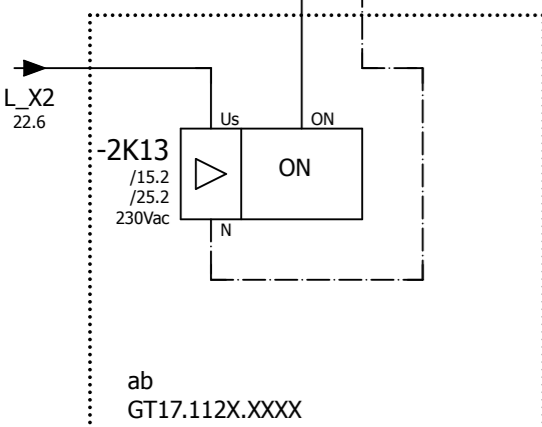
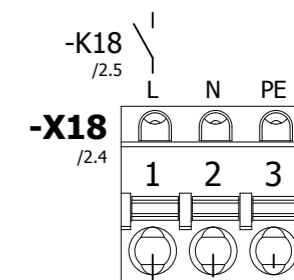
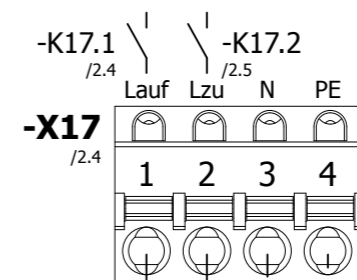
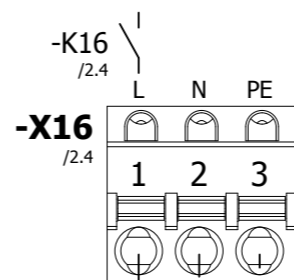
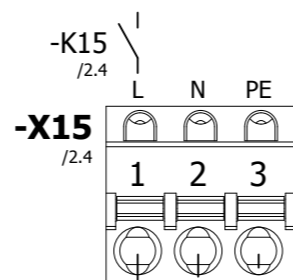
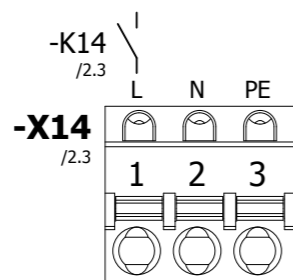
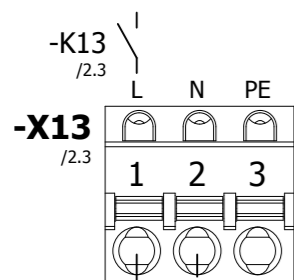

Auger 1

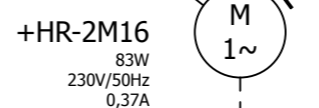
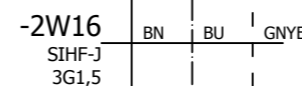

Secondary air blower

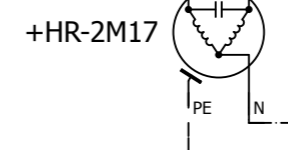

3 way diverting valve

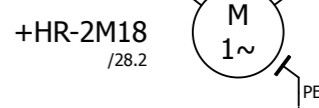
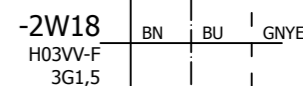

Bypass pump

Date	19.11.2015
Ed.	krj
Appr	
Original	
Modification	
Date	
Name	

GILLES Energie u. Umwelttechnik
 Koaserbauerstraße 16
 A - 4810 Gmunden
 Tel.: (+43) 7612 / 73 76 0 - 0

Standard
 Woodchips / Pellets Heating System

Power unit X13 - X18

HPK-RA 15-160

SIGMATEK HZS 5211 Heating control HZS 5211

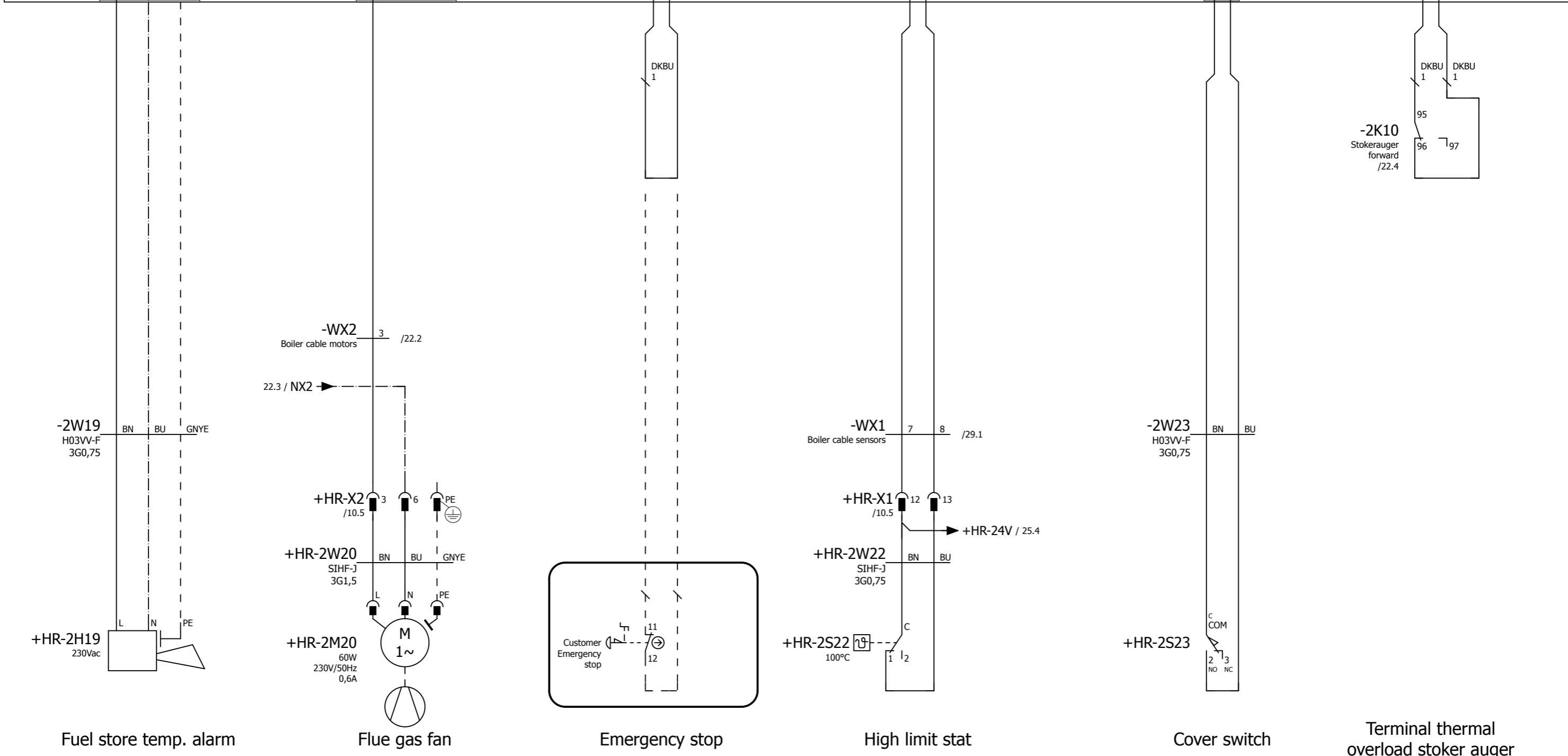
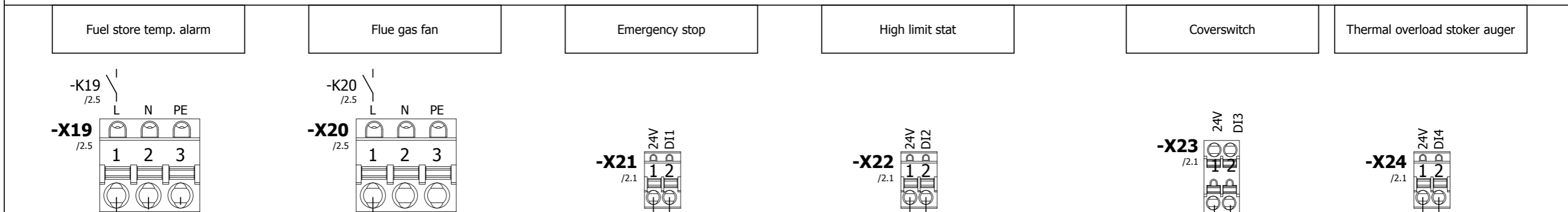

Date	22.10.2015
Ed.	krj
Appr	
Original	
Modification	
Date	
Name	

GILLES Energie u. Umwelttechnik
 Koaserbauerstraße 16
 A - 4810 Gmunden
 Tel.: (+43) 7612 / 73 76 0 - 0

Standard
 Woodchips / Pellets Heating System

Power unit X19 - X24

HPK-RA 15-160

SIGMATEK HZS 5211 Heating control HZS 5211

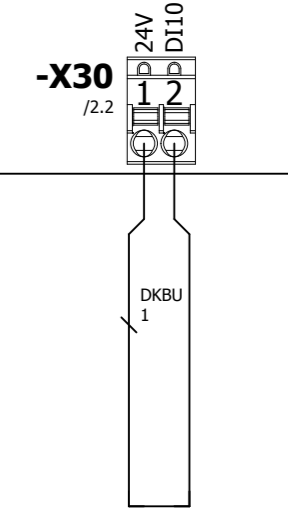
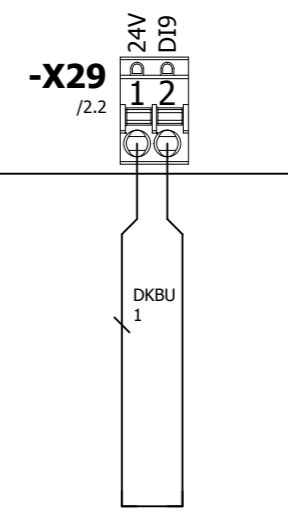
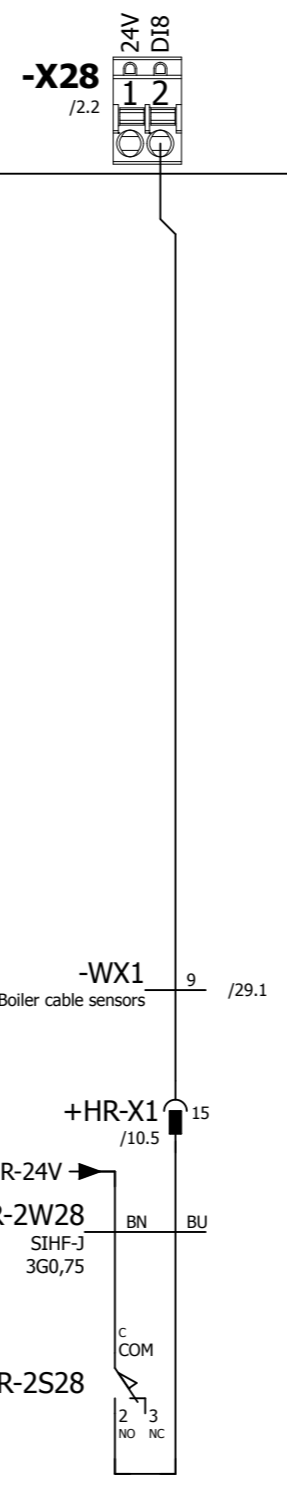
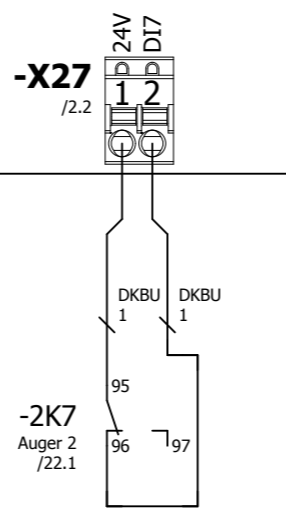
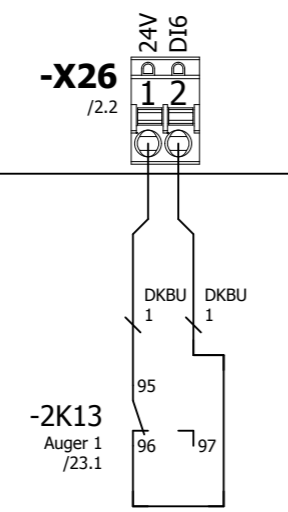
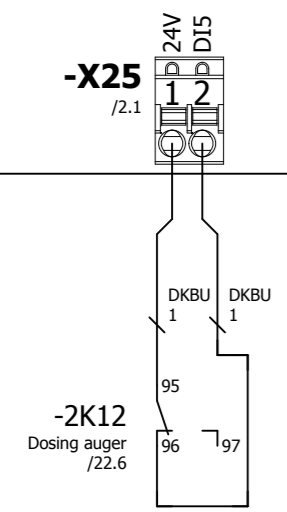

Terminal thermal overload dosing auger

Terminal thermal overload fuel auger 1

Terminal thermal overload fuel auger 2

Boiler door

External enable

Customer contact

Modification	Date	Name	Date	22.10.2015
			Ed.	krj
			Appr	
			Original	

GILLES Energie u. Umwelttechnik
 Koaserbauerstraße 16
 A - 4810 Gmunden
 Tel.: (+43) 7612 / 73 76 0 - 0

Standard
 Woodchips / Pellets Heating System

Power unit X25 - X30

HPK-RA 15-160

SIGMATEK HZS 5211 Heating control HZS 5211

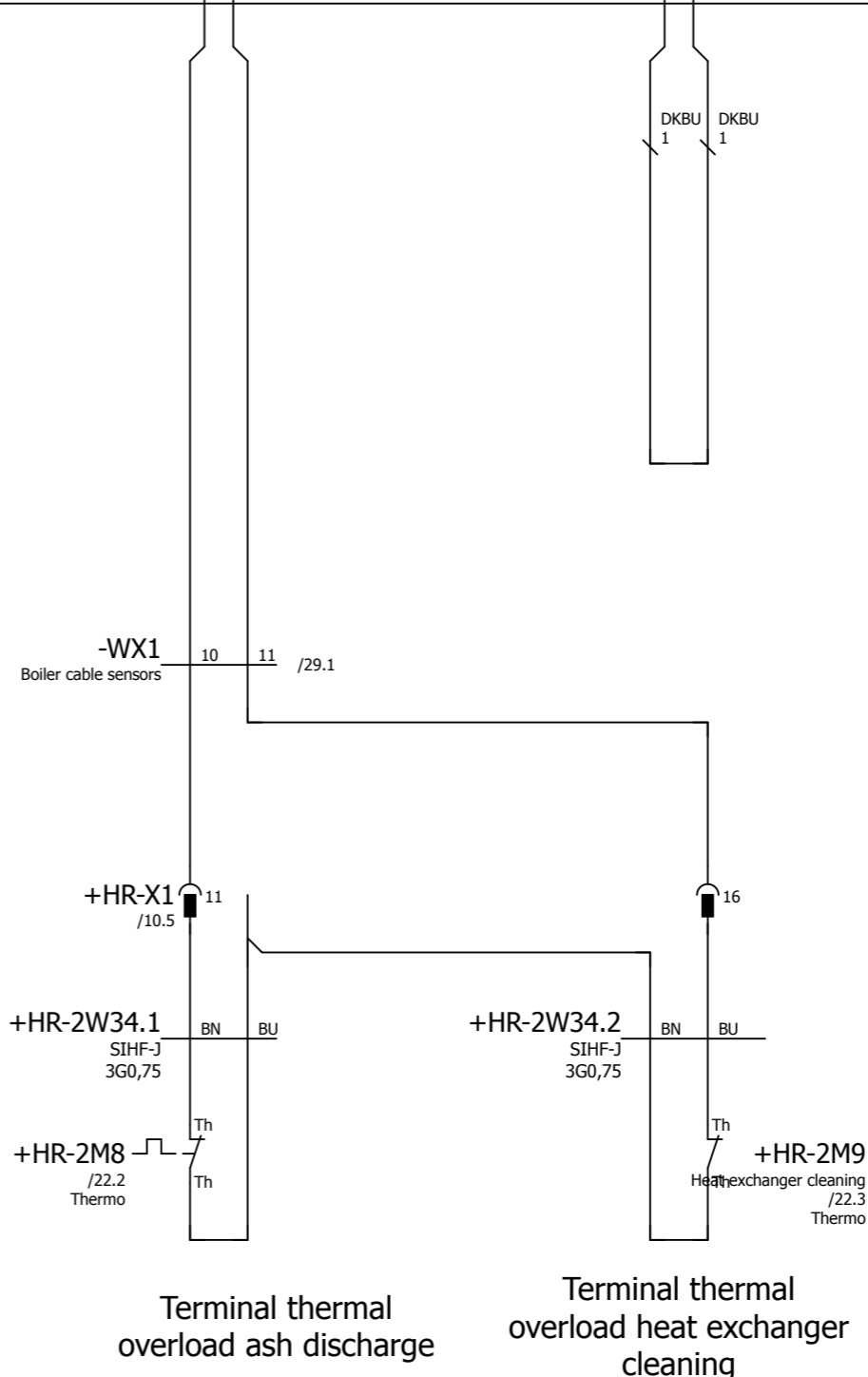
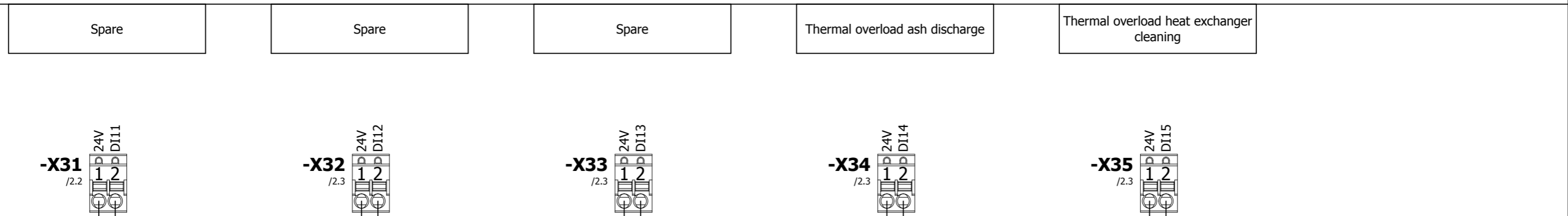

Terminal thermal overload ash discharge

Terminal thermal overload heat exchanger cleaning

Date	22.10.2015
Ed.	krj
Appr	
Original	
Modification	
Date	
Name	

GILLES Energie u. Umwelttechnik
 Koaserbauerstraße 16
 A - 4810 Gmunden
 Tel.: (+43) 7612 / 73 76 0 - 0

Standard
 Woodchips / Pellets Heating System

Power unit X31 - X35

HPK-RA 15-160

SIGMATEK HZS 5211 Heating control HZS 5211

Light Sensor Auger 1

Light Sensor Auger 2

Proximity switch stoker auger

Temperature burner

-X36
/2.3

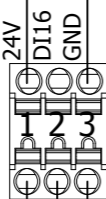

-X37
/2.3

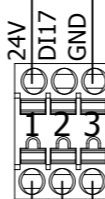

-X38
/2.1



-X39
/2.1



-2W36.1
PUR-OB
4x0,34
10 m

BN BU

+HR-2B36.1
SMT 3000 HC TB-J

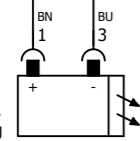

ab
GT17.112X.XXXX

Light sensor transmitter
auger 1

-2W36.2
PUR-OB
4x0,34
10 m

BN BU BK

+HR-2B36.2
SMR 3215 TB-J

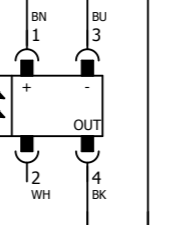

Light sensor receiver
auger 1

-2W37.1
PUR-OB
4x0,34
10 m

BN BU

+HR-2S37.1
SMT 3000 HC TB-J

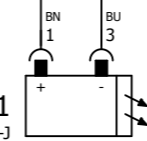

ab
GT17.113X.XXXX

Light sensor transmitter
auger 2

-2W37.2
PUR-OB
4x0,34
10 m

BN BU BK

+HR-2S37.2
SMR 3215 TB-J

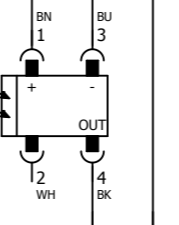

Light sensor receiver
auger 2

-2W38
PUR
4x0,22

BN BU BK

+HR-2S38

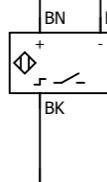

Proximity switch stoker
auger

Date	22.10.2015
Ed.	krj
Appr	
Original	
Modification	
Date	
Name	

GILLES Energie u. Umwelttechnik
 Koaserbauerstraße 16
 A - 4810 Gmunden
 Tel.: (+43) 7612 / 73 76 0 - 0

Standard
 Woodchips / Pellets Heating System

Power unit X36 - X39

HPK-RA 15-160

-A2
/2.1

SIGMATEK HZS 5211 Heating control HZS 5211

Key switch fuel store filling

Fault bypass pump

Speedrecognition Fluegasfan

Speedrecognition Stokerauger

required Speed Fluegas-Fan

Lambda probe

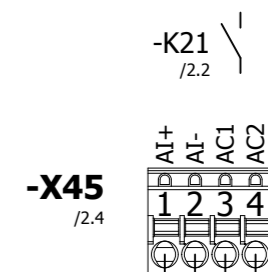
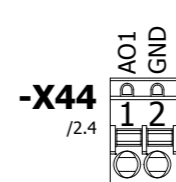
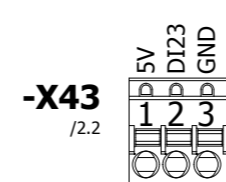
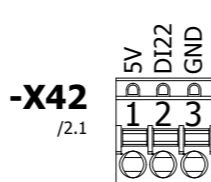
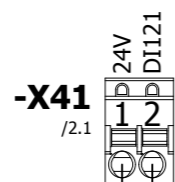
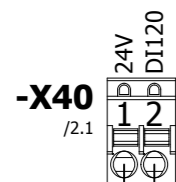

-K21
/2.2

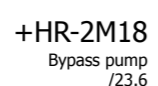
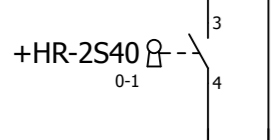
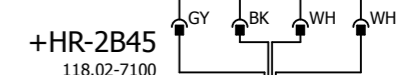
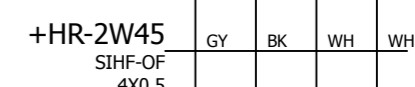
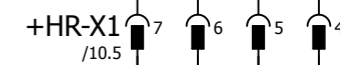
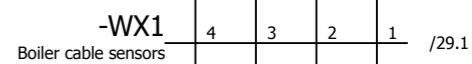
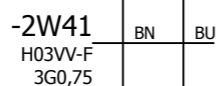
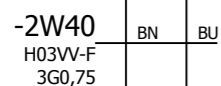

Key switch fuel store filling

Fault bypass pump

Lambda probe

27

29

Date	22.10.2015
Ed.	krj
Appr	
Original	
Modification	
Date	
Name	

GILLES Energie u. Umwelttechnik
 Koaserbauerstraße 16
 A - 4810 Gmunden
 Tel.: (+43) 7612 / 73 76 0 - 0

Standard
 Woodchips / Pellets Heating System

Power unit X40 - X45

HPK-RA 15-160

= SLP Wiring diagram
 + EC01 Switch cabinet
 Page 28

SIGMATEK HZS 5211 Heating control HZS 5211

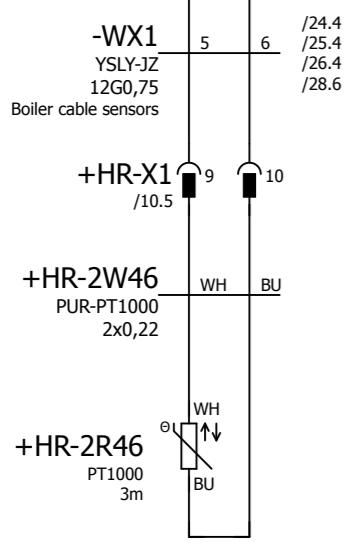
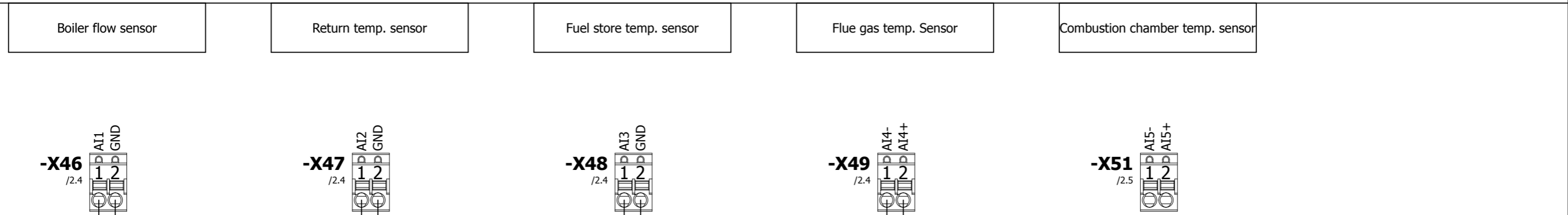

Boiler flow sensor

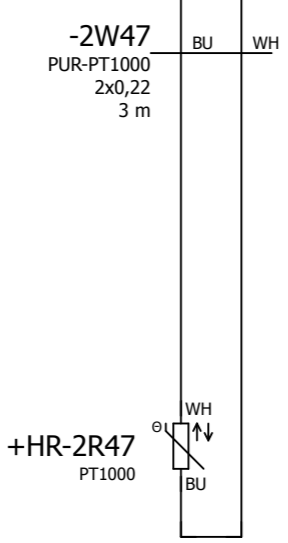

Return temp. sensor

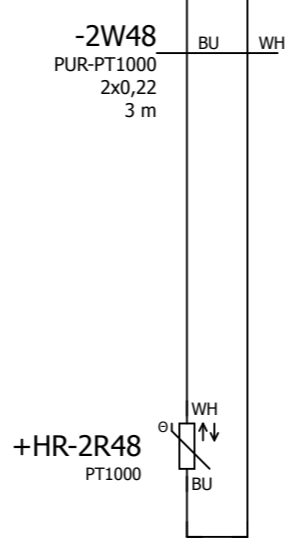

Fuel store temp. sensor

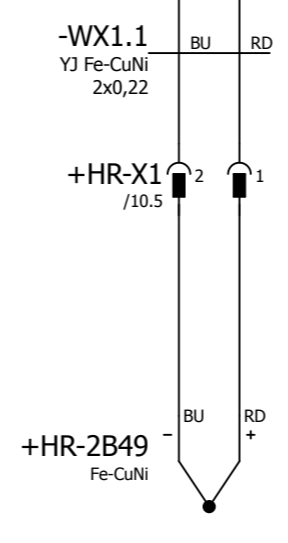

Flue gas temp. Sensor

Modification	Date	Name	Appr	Date	22.10.2015
			Original	Ed.	krj

GILLES **Gilles Energie u. Umwelttechnik**
Koaserbauerstraße 16
A - 4810 Gmunden
Tel.: (+43) 7612 / 73 76 0 - 0

Standard
Woodchips / Pellets Heating System

Power unit X46 - X51

HPK-RA 15-160

-A2
/2.1

SIGMATEK HZS 5211 Heating control HZS 5211

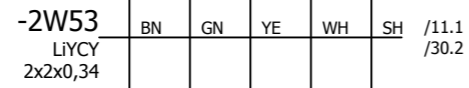
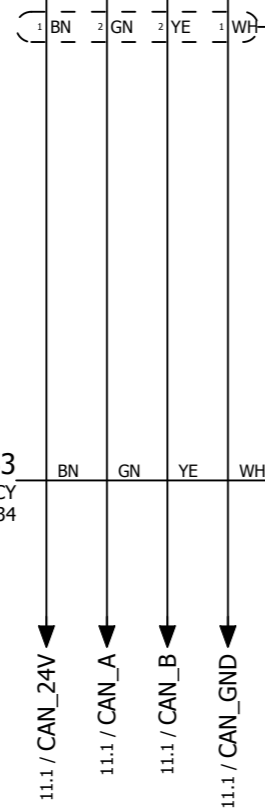
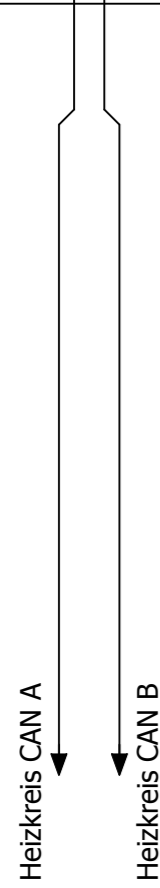
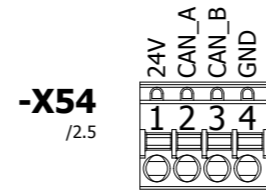
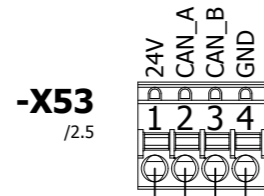
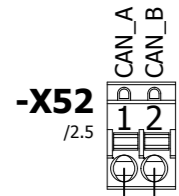
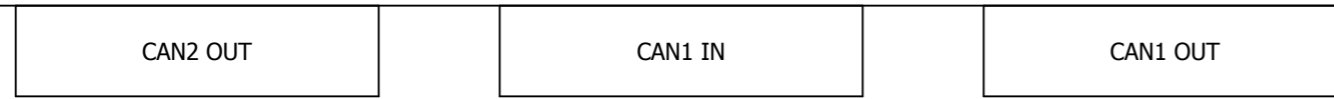

CAN Bus

Date	13.11.2015
Ed.	krj
Appr	
Original	
Modification	
Date	
Name	

GILLES Energie u. Umwelttechnik
 Koaserbauerstraße 16
 A - 4810 Gmunden
 Tel.: (+43) 7612 / 73 76 0 - 0

Standard
 Woodchips / Pellets Heating System

Power unit X52 - X54

HPK-RA 15-160

Pin-connection diagram

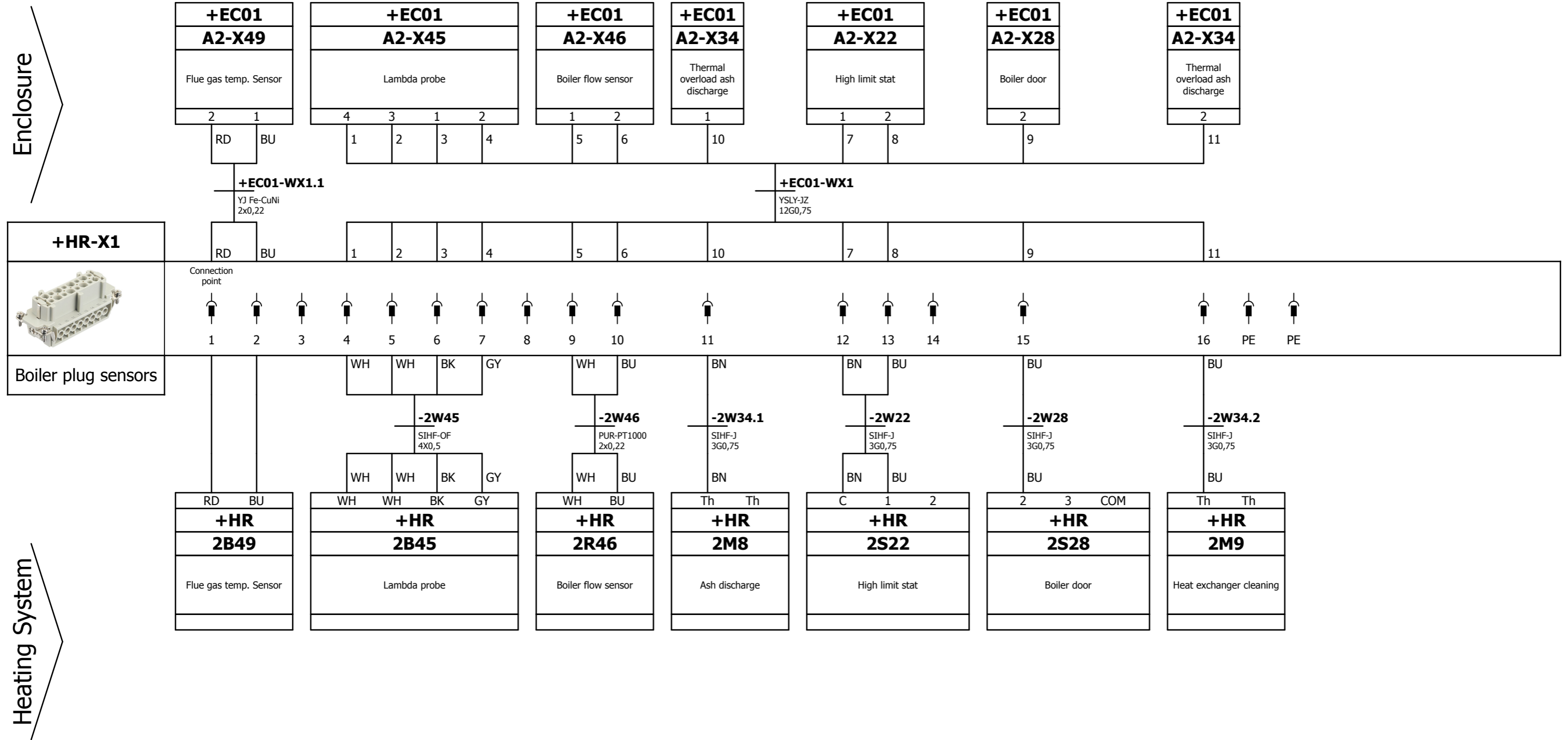

=SLP+EC01/30

Date	19.11.2015
Ed.	krj
Appr	
Original	
Modification	Date
	Name

GILLES Energie u. Umwelttechnik
 Koaserbauerstraße 16
 A - 4810 Gmunden
 Tel.: (+43) 7612 / 73 76 0 - 0

Standard
 Woodchips / Pellets Heating System

Pin-connection diagram +HR-X1

HPK-RA 15-160

Pin-connection diagram

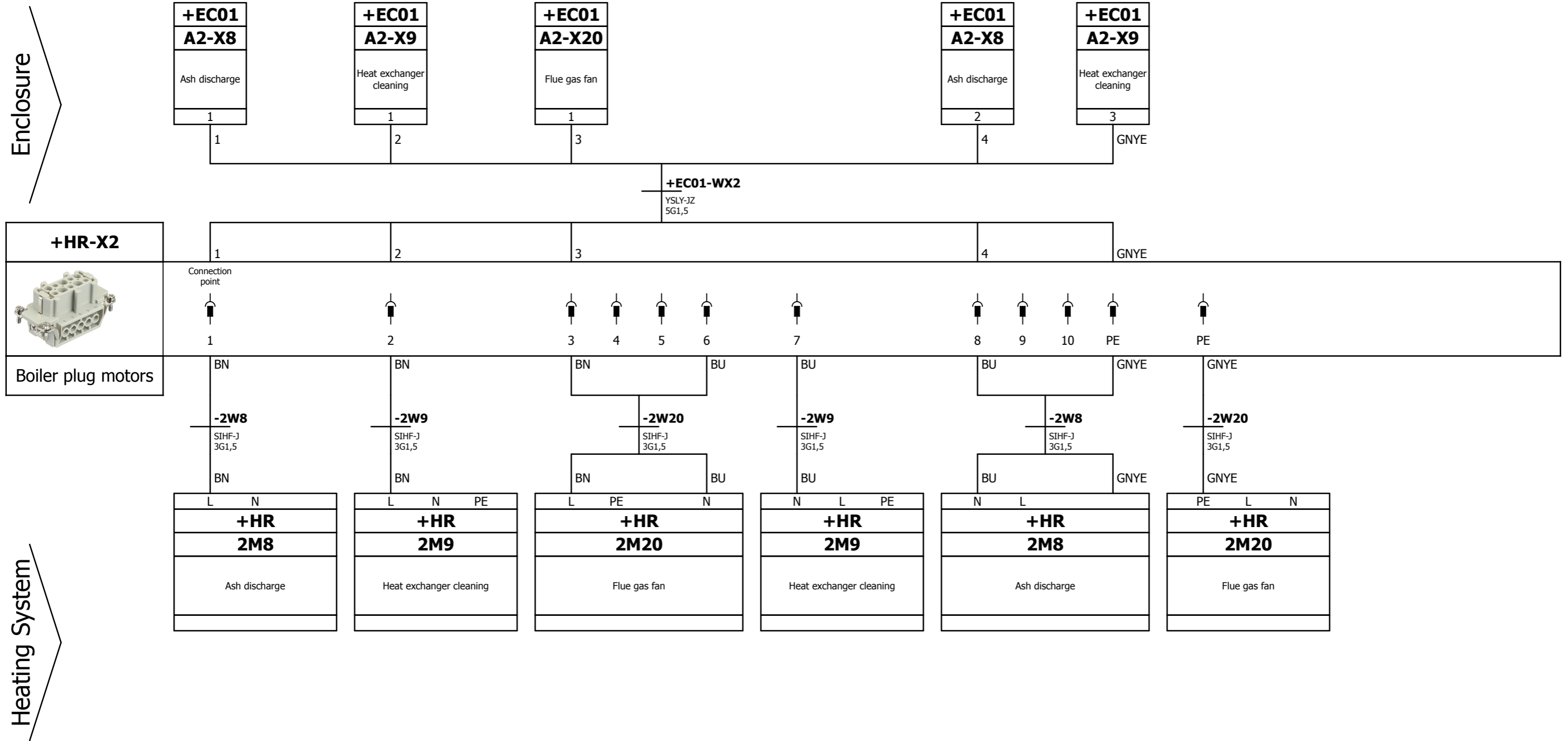

Date	19.11.2015	Gilles Energie u. Umwelttechnik Koaserbauerstraße 16 A - 4810 Gmunden Tel.: (+43) 7612 / 73 76 0 - 0	Standard	Pin-connection diagram +HR-X2	HPK-RA 15-160	= STAP Pin-connection diagram
Ed.	krj					+ Page
Modification	Date	Name	Appr Original			Page